

Camera tutorial

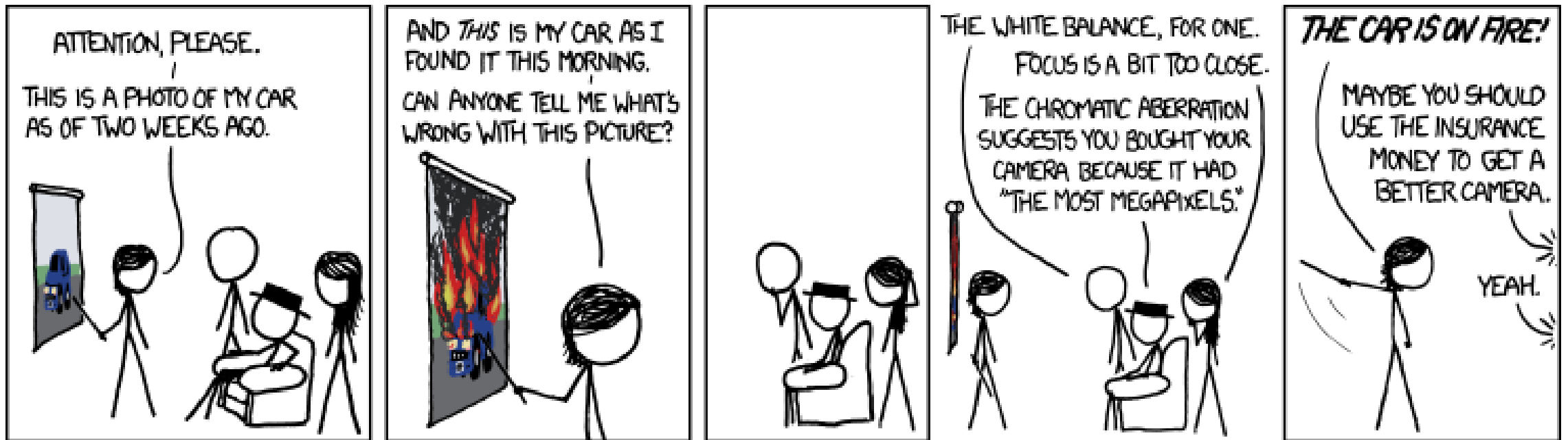

15-463, 15-663, 15-862
Computational Photography
Fall 2023

Taking a photograph with your mobile phone camera

Once you find something you want to photograph:

1. “Frame” your scene.
2. Press the “shutter release” button.



Taking a photograph with a camera with manual controls

Once you find something you want to photograph:

1. "Frame" your scene.
2. Set the lens.
 - a) Select zoom.
 - b) Select focus.
 - c) Select aperture.
3. Set the exposure.
 - a) Select shutter speed.
 - b) Select aperture.
 - c) Select ISO.

Go back
and do it
again
(possibly
several
times).

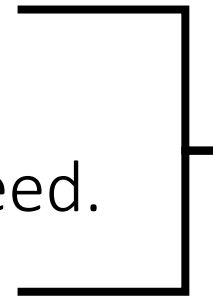

Appears
twice??

4. Eventually press the shutter release.

Also decide on white balance, lighting (if possible), and so on.



Trade-off: convenience versus creative control

Nowadays, the camera can make most lens and exposure decisions on its own.

- You still need to select the scene and do the framing (for now).

Having the option to make these decisions on our own can serve creativity.

- Also, in a few cases, we can still do a better job than the camera in deciding settings.
- (Also you need to control these settings for your homework!)



Important

Do not agonize about setting everything correctly.

Taking slightly imperfect photos is more important than spending most of your time fiddling with settings.

Your cameras

- Three Nikon camera models: D3300, D3400, D3500.
- Slightly different placement of controls and menu options, but otherwise very similar.
- Check your camera model! The tutorial uses photos of D3400.



Your lenses

- Three versions of the same lens: AF-S DX Nikkor 18-55mm f/3.5-5.6 G ED, AF-S DX Nikkor 18-55mm f/3.5-5.6 G VR, AF-S DX Nikkor 18-55mm f/3.5-5.6 G VR II.
- Effectively identical as far as this course is concerned.



Your lenses

- Three versions of the same lens: AF-S DX Nikkor 18-55mm f/3.5-5.6 G ED, AF-S DX Nikkor 18-55mm f/3.5-5.6 G VR, AF-S DX Nikkor 18-55mm f/3.5-5.6 G VR II.
- Effectively identical as far as this course is concerned.

What do all these letters mean?

- AF-S: auto-focusing with a silent wave motor, Nikon's current auto-focus technology.
- DX: lens designed for APS-C sensor format ("half frame" size).
- Nikkor: Nikon's lens subsidiary, all lenses made by Nikon are marked this.
- 18-55mm: the focal length range of this *zoom* lens.
- f/3.5-5.6: minimum f-number (maximum aperture size), varies with focal length.
- G: short for "gilded", means that the lens does not have a separate aperture ring.
- ED: short for "extra-low dispersion" optical elements to reduce chromatic aberration.
- VR: short for "vibration reduction", Nikon's image stabilization technology.

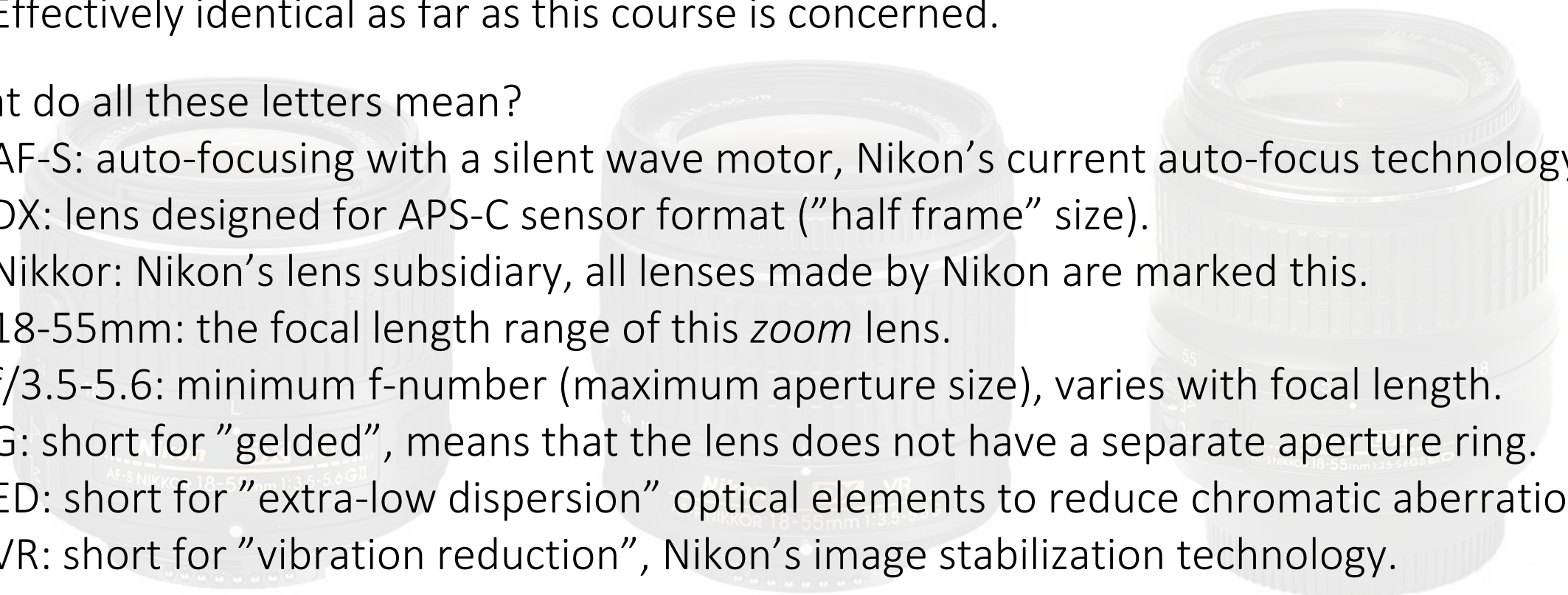

Setting up the shot

Either preview the photo by looking through the viewfinder...

Or use live view to preview it on the LCD.



Toggles between the two modes.

Deciding the lens zoom and focus

- First press the marked button and rotate to unlock the lens.

Focus ring: controls distance of lens from sensor.

(focus ring hidden here)



(unlock button hidden here)



Zoom ring: controls focal length of lens.

Manual focus in DSLR cameras

- Same view as main lens.
- Just rotate the focusing ring until you are satisfied by the sharpness.
- Viewfinder indicators can help this process.
- You need to half-press shutter release to see focus indicators.

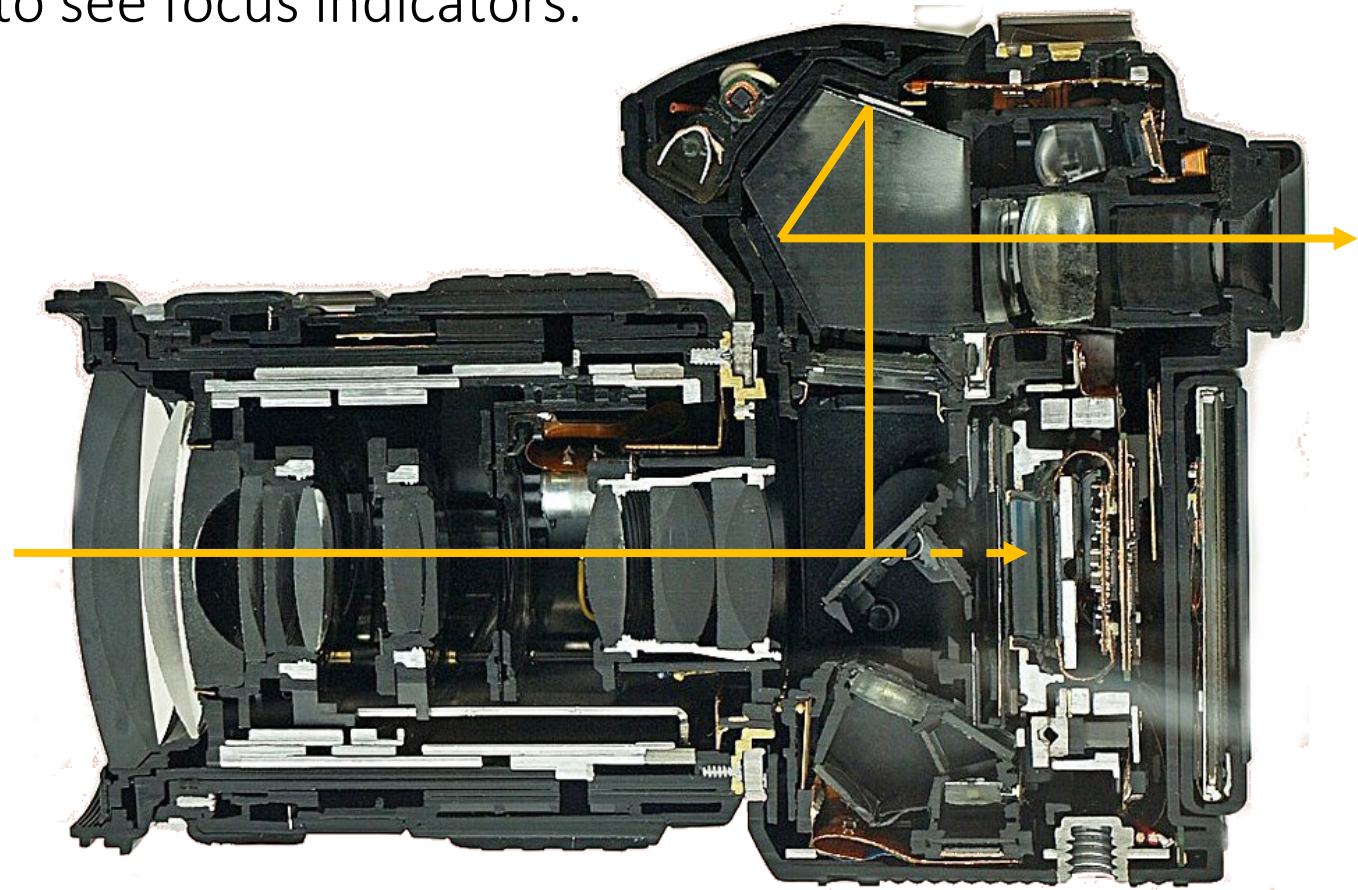
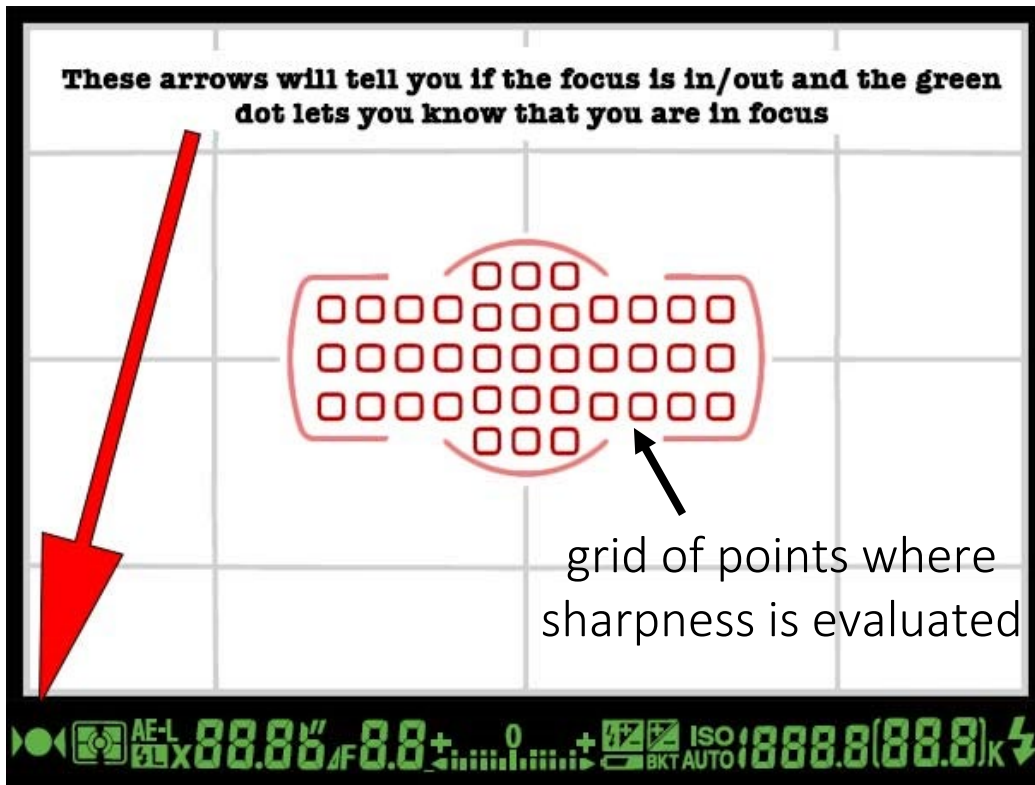

Enabling and disabling auto-focus on your camera

MENU button can be used to access most camera settings...

And the *i* button is a quick way to access settings shown in the bottom row.



Exposure controls brightness of image

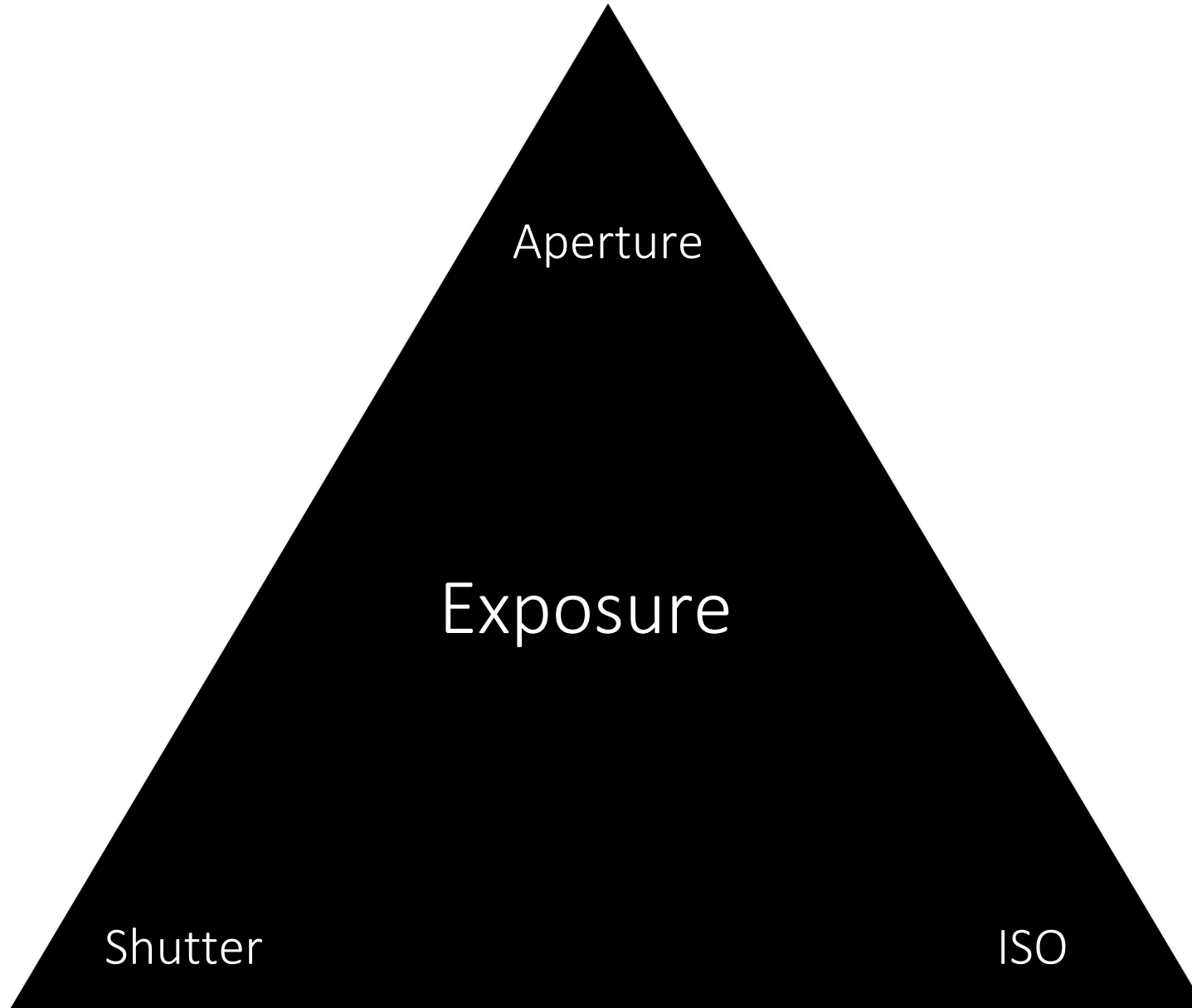

Exposure mode

Deciding which exposure mode to use depends on:

- The type of scene you are imaging.
- Your camera.
- Your own experience and preferences.



Mode dial of Nikon D3400

Exposure mode

Auto mode:

- Camera sets aperture, shutter speed, and ISO on its own.
- “Point and shoot” mode.

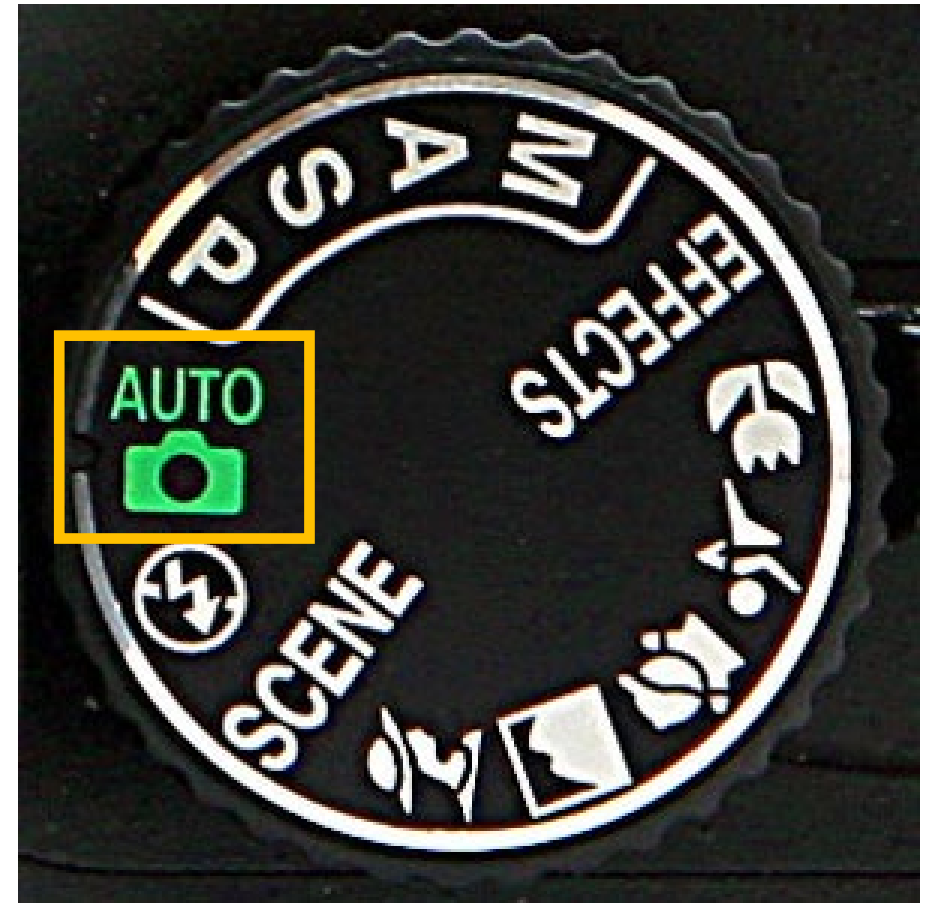

Mode dial of Nikon D3400

Exposure mode

Shutter priority mode:

- You select the shutter speed.
- Camera sets the aperture (and maybe ISO).



Mode dial of Nikon D3400

Exposure mode

Aperture priority mode:

- You select the aperture.
- Camera sets the shutter speed (and maybe ISO).

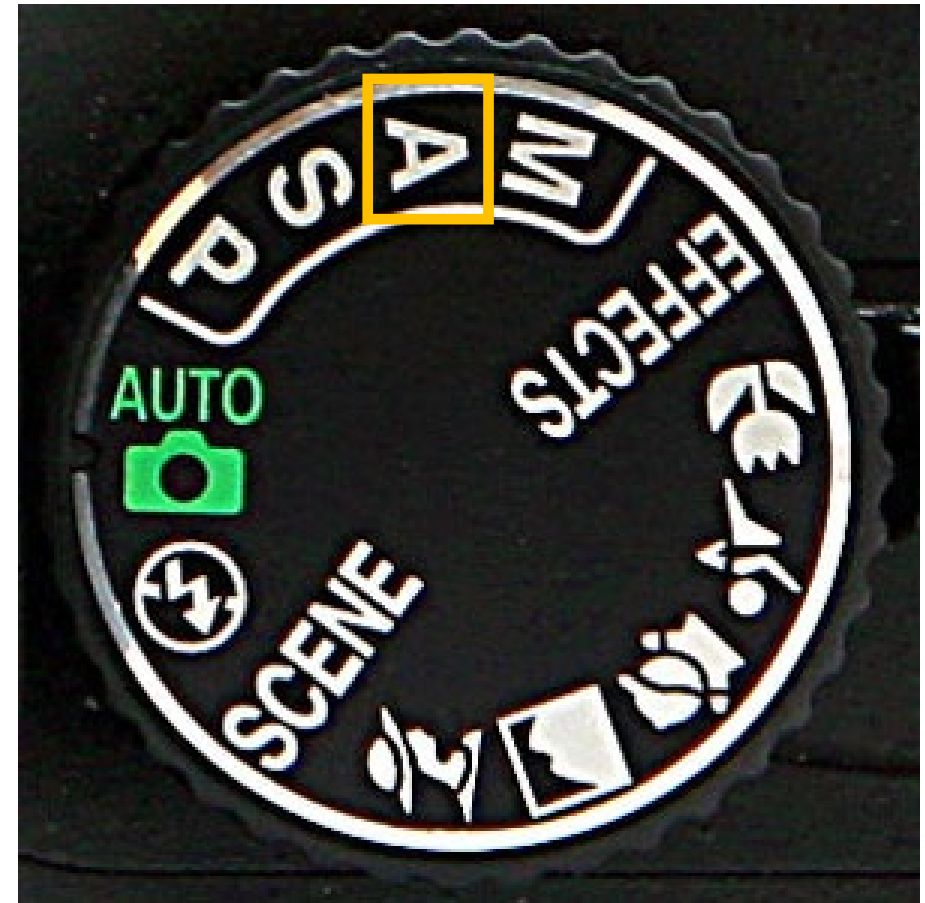

Mode dial of Nikon D3400

Exposure mode

Manual priority mode:

- You select the both the shutter speed and aperture.
- Generally what you want to use for most assignments!



Mode dial of Nikon D3400

How do you select aperture or shutter speed?



Control dial: Changes shutter speed or aperture, depending on exposure mode.

Display: Shows current exposure settings.

How do you select aperture or shutter speed?



When in manual mode, hold the selector button to change aperture with the control dial.

Otherwise, the selector dial changes shutter speed.

What about ISO?



Same locations: the menu and the *i* button.

What about ISO?

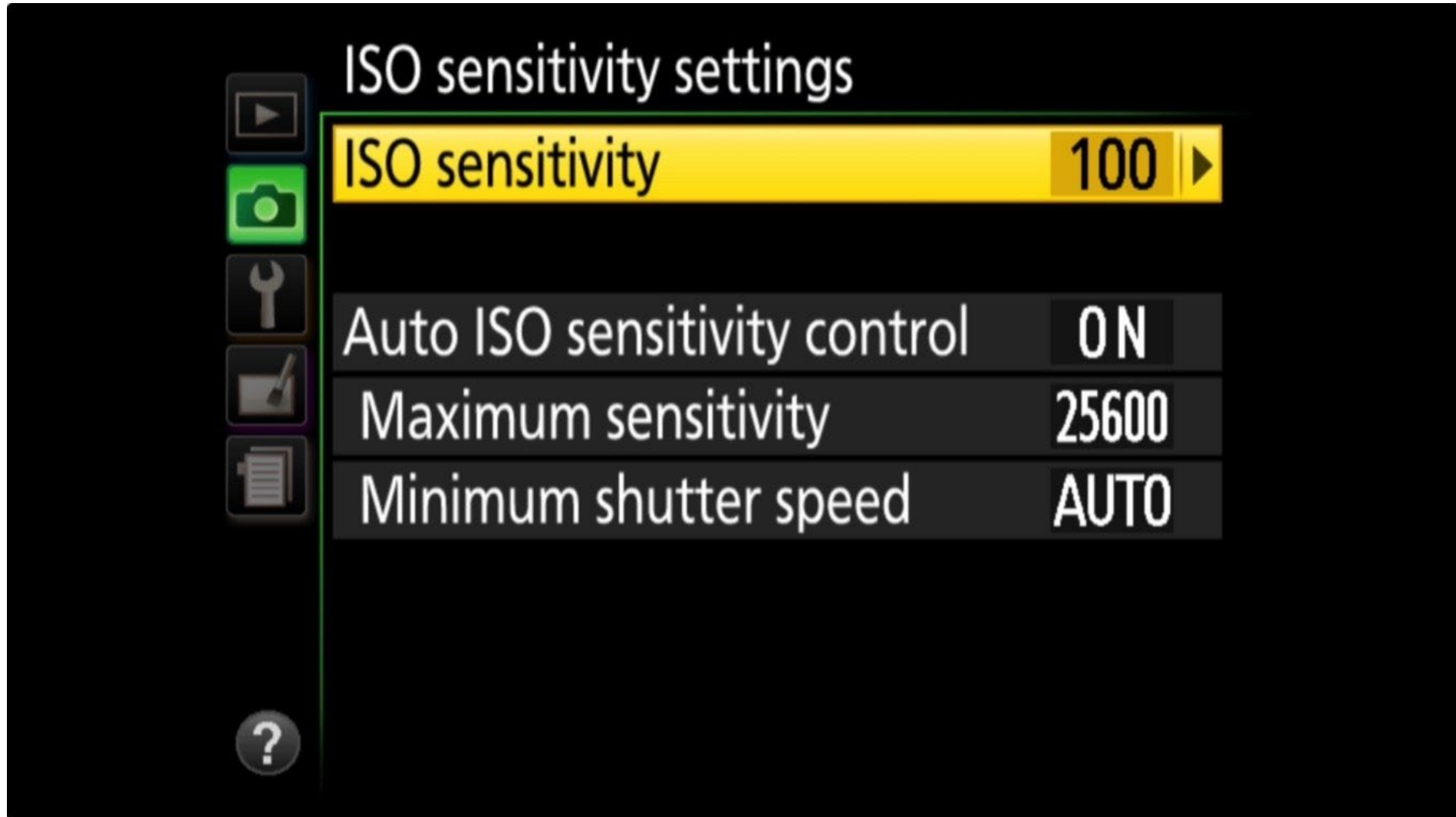

Using flash



Default is no flash in P, S, A, M exposure modes.

Push flash button to enable flash.

Gently push down flashlight to disable.

White balancing presets

Cameras nowadays come with a large number of presets: You can select which light you are taking images under, and the appropriate white balancing is applied.

