

Pinholes and lenses



15-463, 15-663, 15-862
Computational Photography
Fall 2021, Lecture 3

Course announcements

- Homework assignment 1 is out.
 - Due September 17th.
 - Start early! Second part takes a lot of time and requires considerable handiwork.
 - Any issues with homework assignment 1?
- Camera distribution this week: come by during office hours.
- Office hours for the semester:
 - Alice: Tuesdays 3:00 – 5:00 pm.
 - Jenny: Wednesdays 3:00 – 5:00 pm.
 - Yannis: Thursdays 3:00 – 5:00 pm.
 - All office hours are on Smith Hall graphics lounge.
- Make sure to join the course Slack server, details posted on Piazza.

Overview of today's lecture

- Some motivational imaging experiments.
- Pinhole camera.
- Accidental pinholes.
- The thin lens model.
- Lens camera and pinhole camera.
- Perspective.
- Field of view.
- Orthographic camera and telecentric lenses.

Slide credits

Many of these slides were adapted from:

- Kris Kitani (15-463, Fall 2016).
- Fredo Durand (MIT).
- Gordon Wetzstein (Stanford).

The modern photography pipeline



post-capture processing
(lectures 5-10)

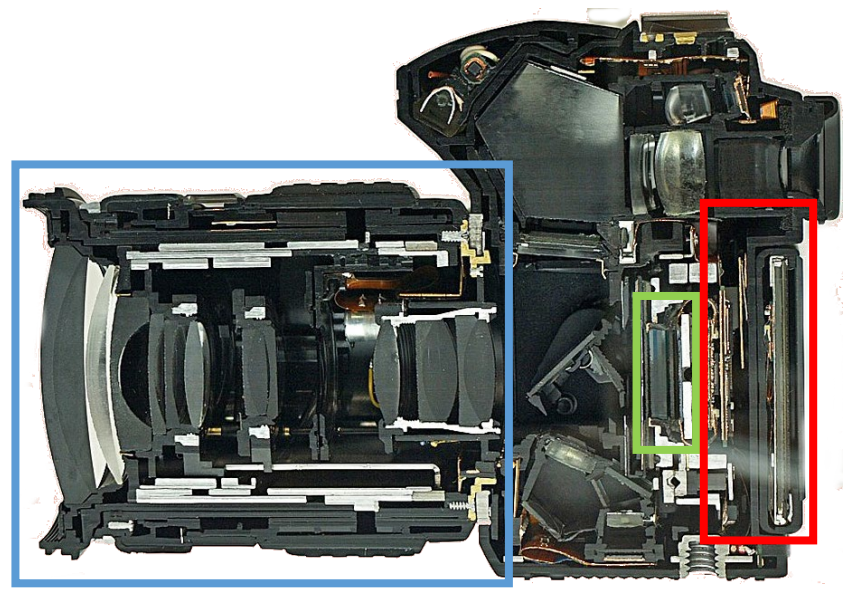

optics and optical controls

(lectures 2-3, 11-20)



sensor, analog front-end, and color filter array

(lectures 2, 23)



in-camera image processing pipeline

(lecture 2)

Some motivational imaging experiments

Let's say we have a sensor...



digital sensor
(CCD or CMOS)

... and an object we like to photograph

real-world
object



digital sensor
(CCD or CMOS)



What would an image taken like this look like?

Bare-sensor imaging

real-world
object



digital sensor
(CCD or CMOS)



Bare-sensor imaging

real-world
object



digital sensor
(CCD or CMOS)

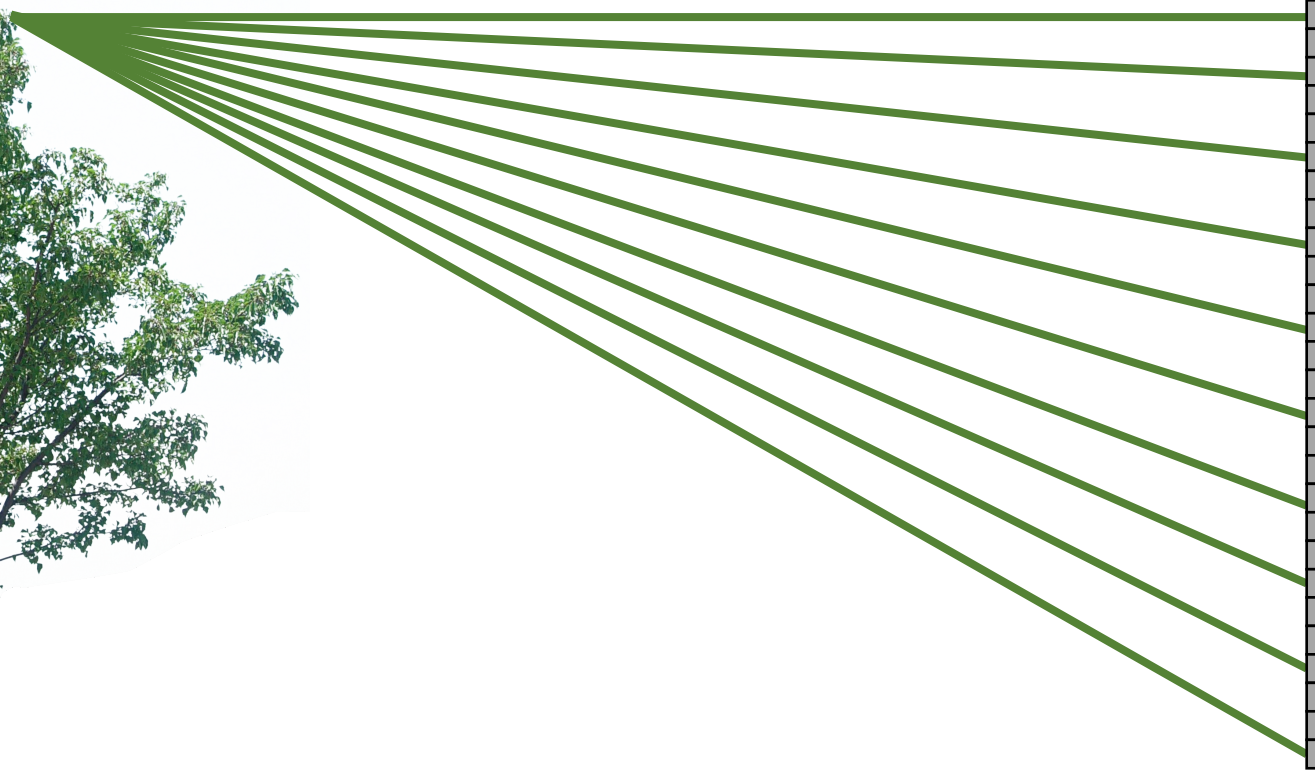

Bare-sensor imaging

real-world
object

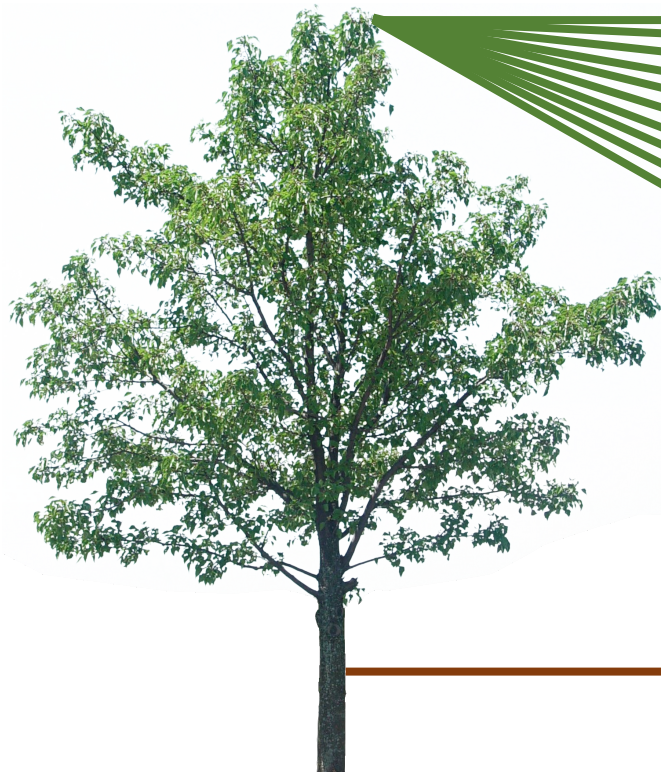

digital sensor
(CCD or CMOS)

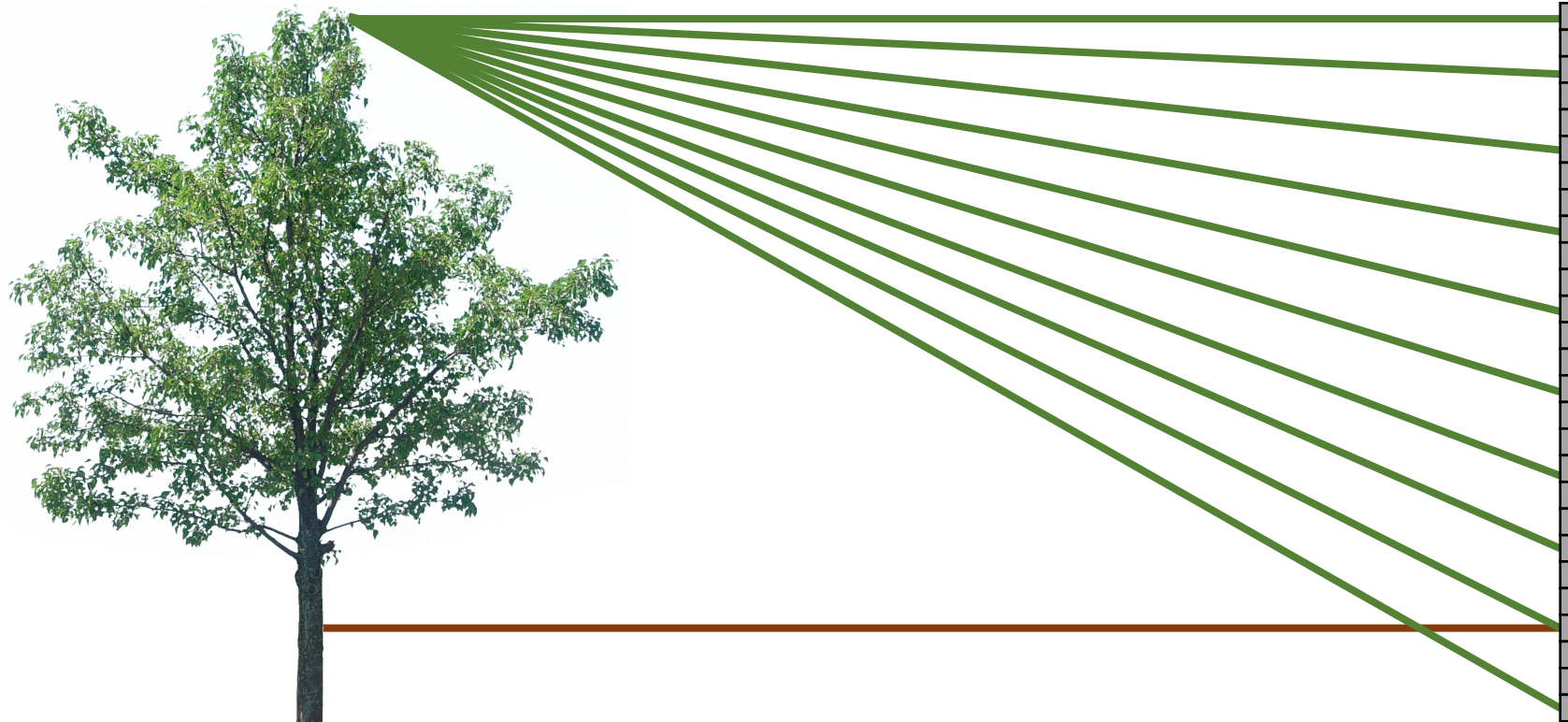

Bare-sensor imaging

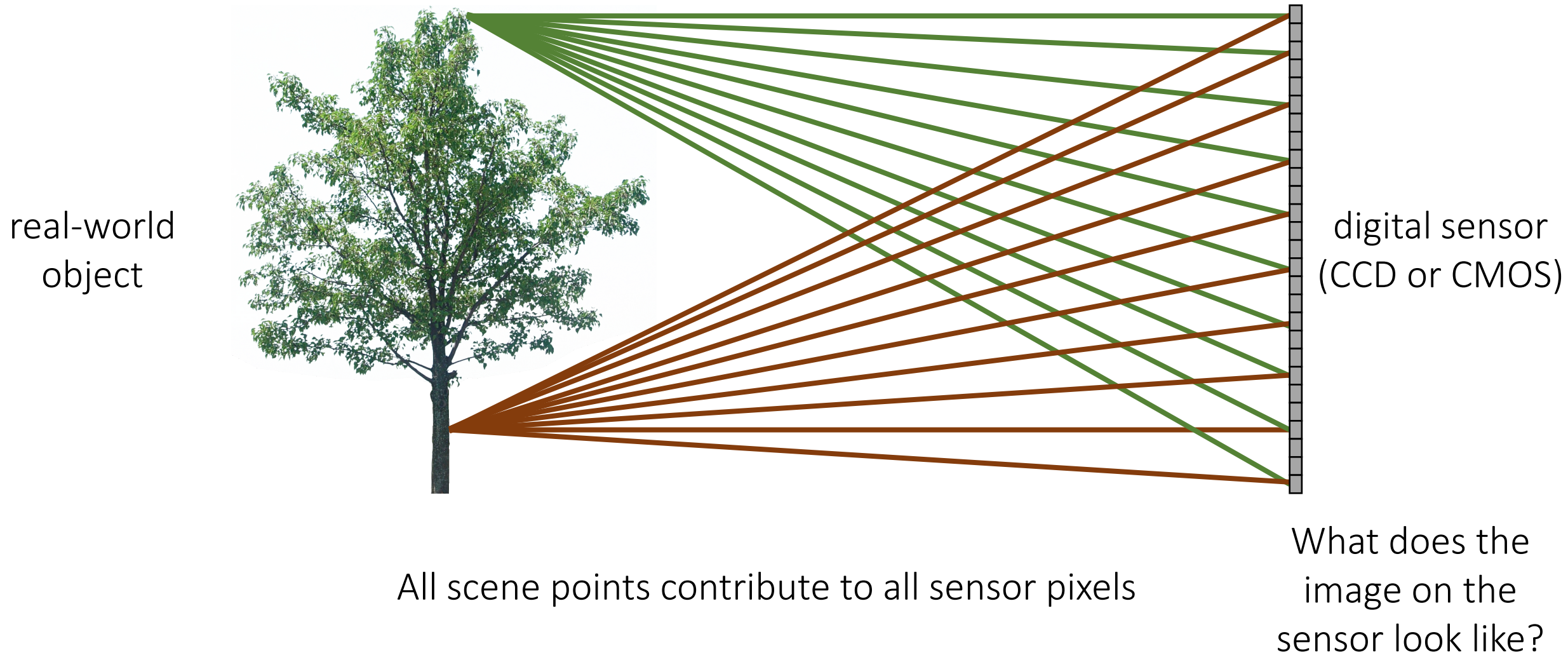

Bare-sensor imaging



All scene points contribute to all sensor pixels

What can we do to make our image look better?

real-world
object



digital sensor
(CCD or CMOS)



Let's add something to this scene

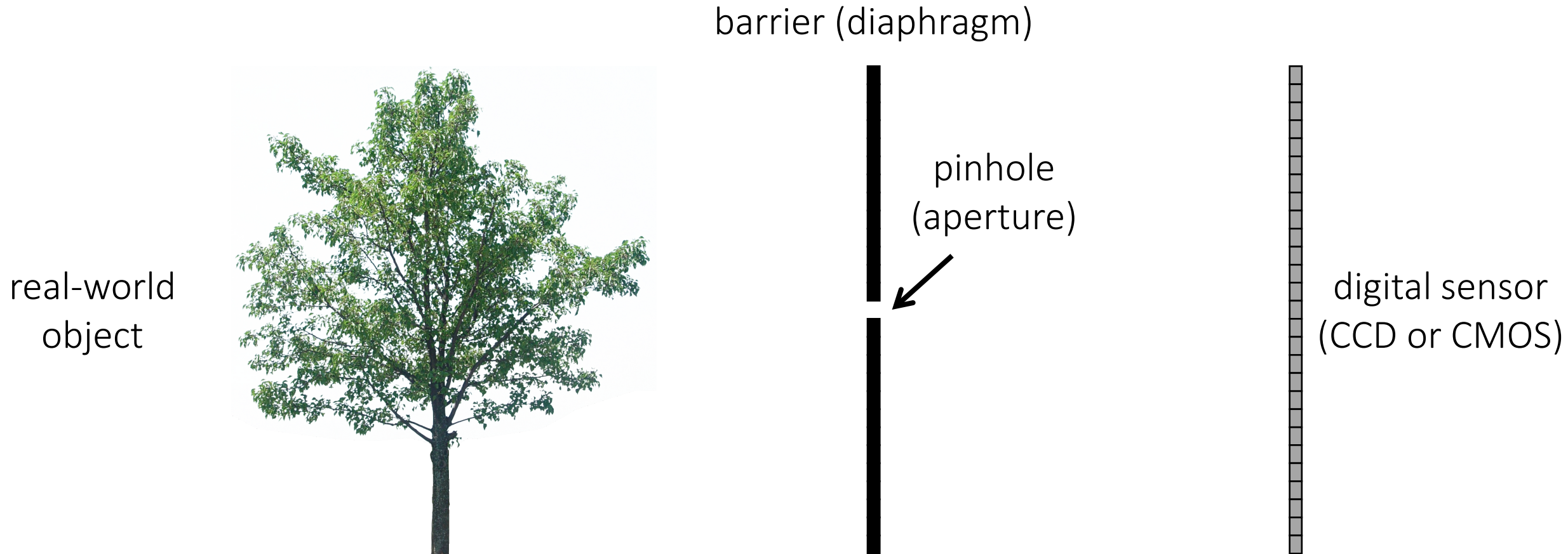

What would an image taken like this look like?

Pinhole imaging

real-world
object



most rays
are blocked

one makes
it through

digital sensor
(CCD or CMOS)

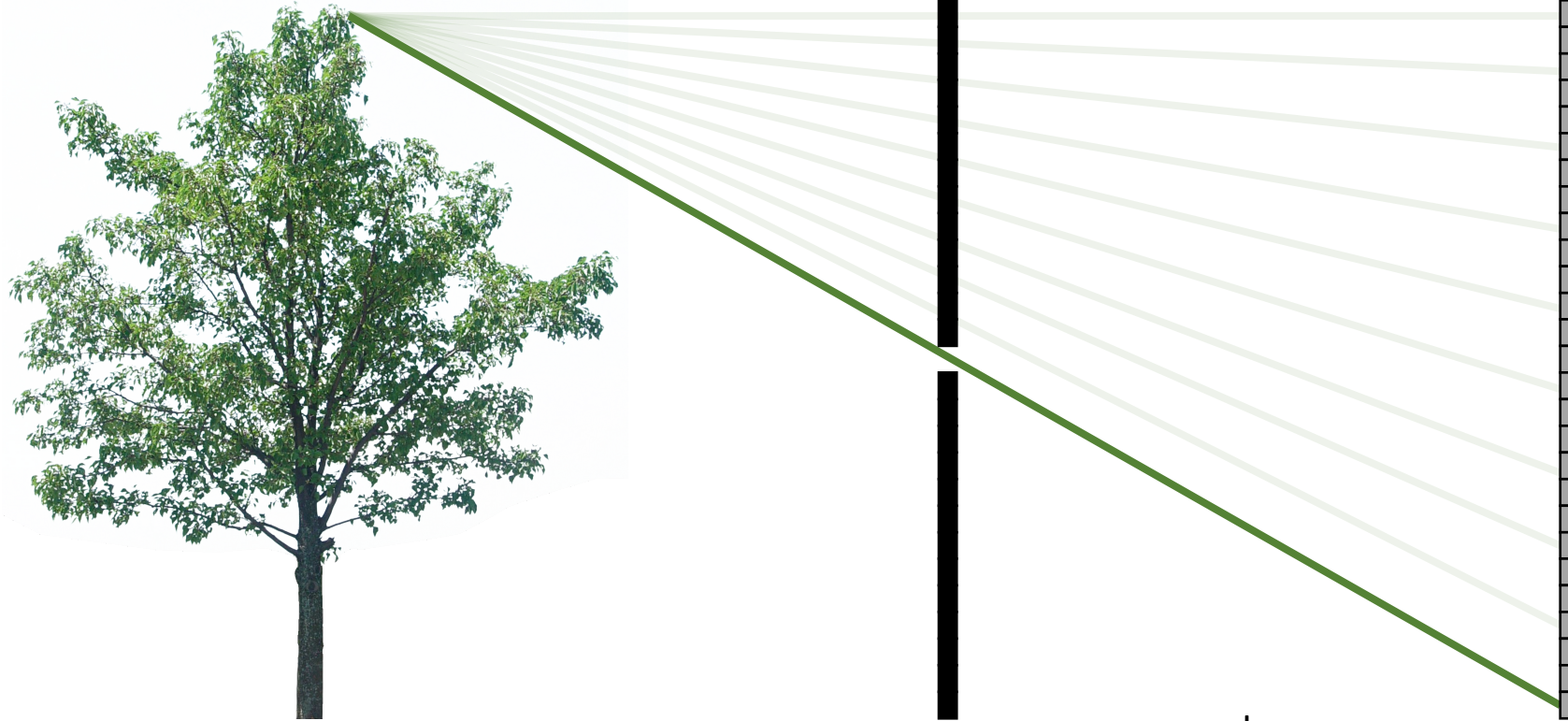

Pinhole imaging

real-world
object



most rays
are blocked

one makes
it through

digital sensor
(CCD or CMOS)

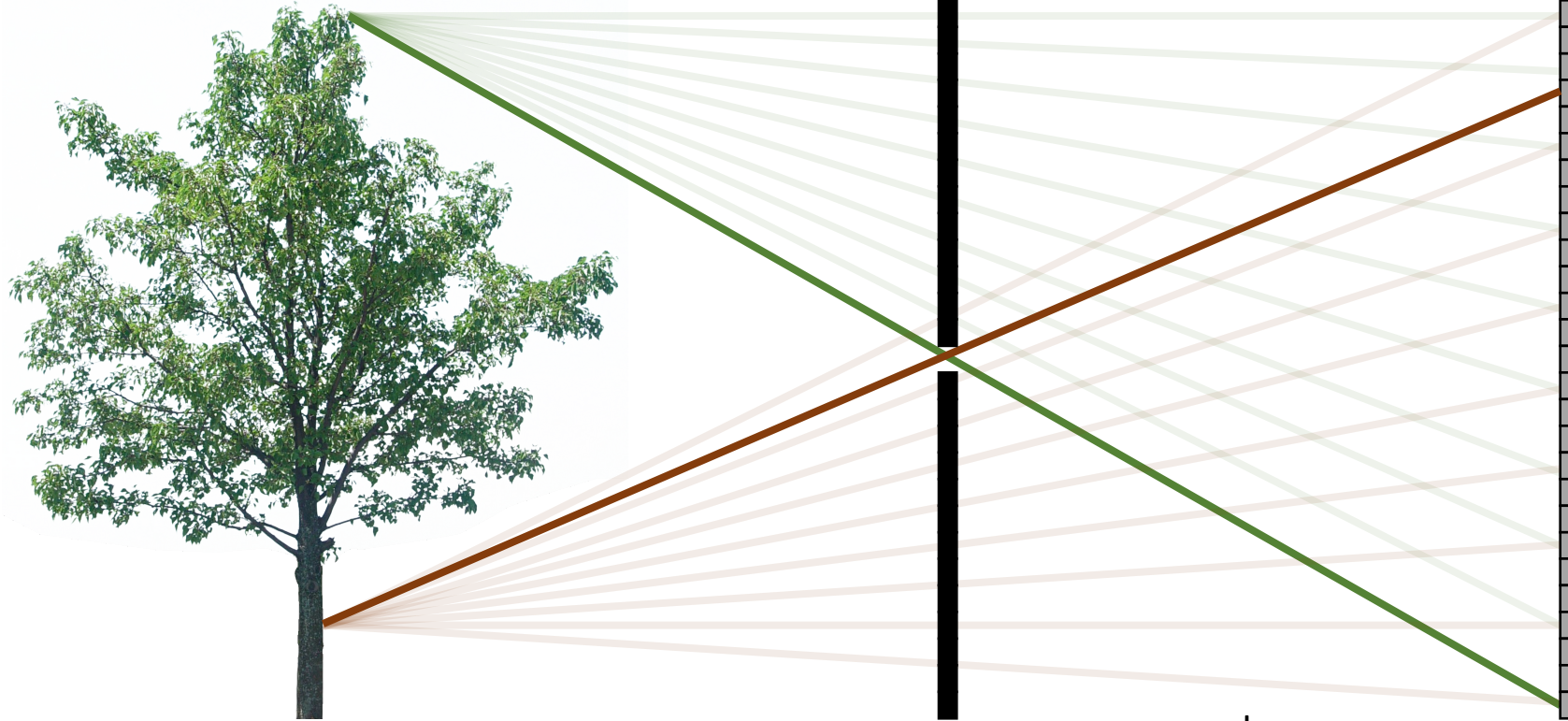

Pinhole imaging

real-world
object

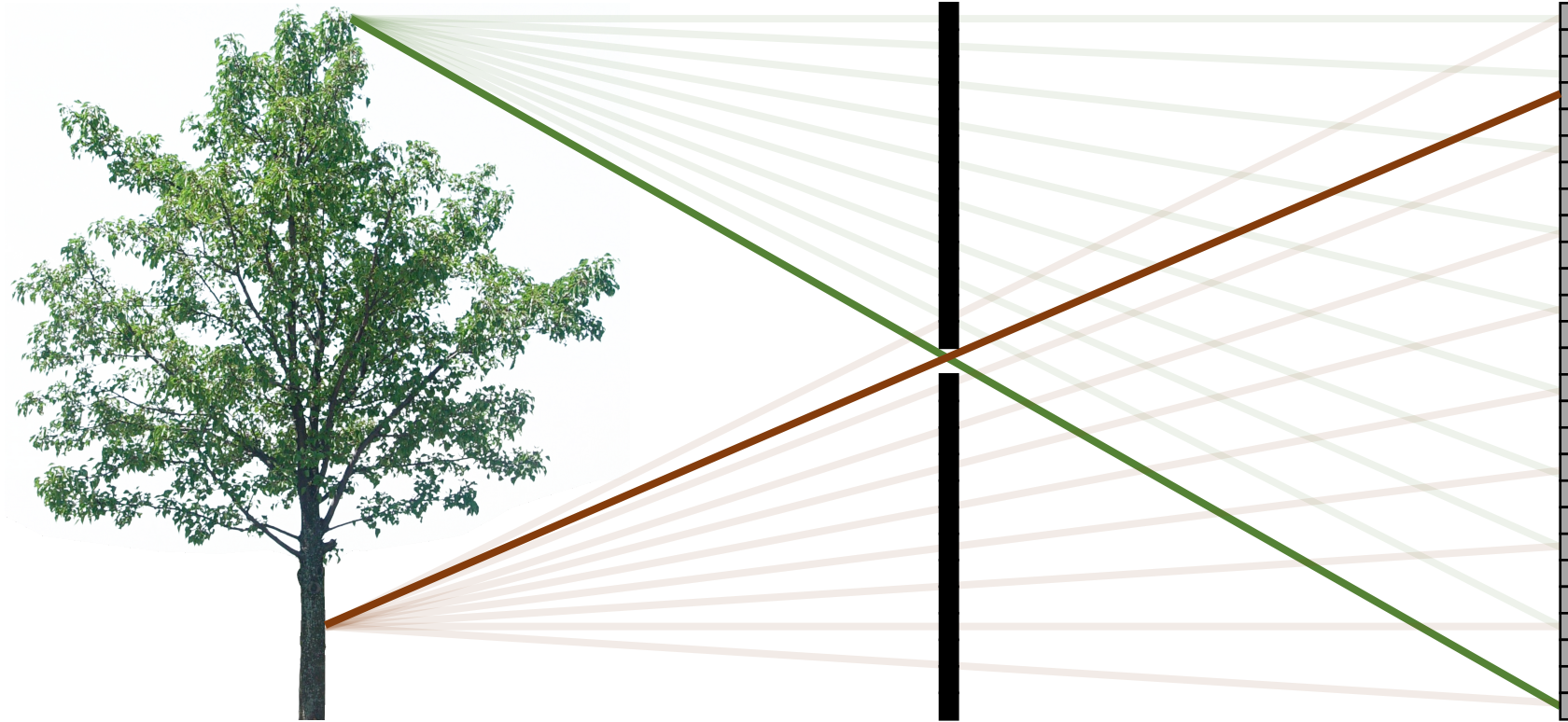

digital sensor
(CCD or CMOS)

Each scene point contributes to only one sensor pixel

What does the
image on the
sensor look like?

Pinhole imaging

real-world
object

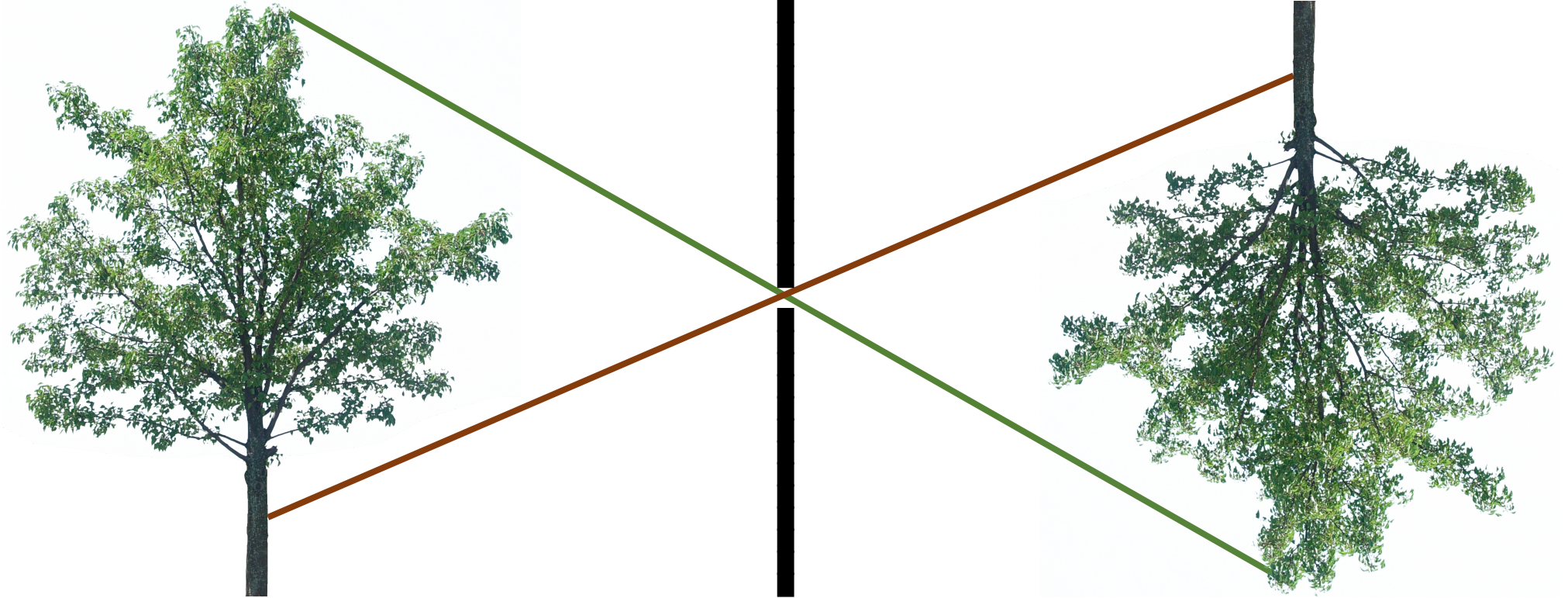

copy of real-world object
(inverted and scaled)

Pinhole camera

Pinhole camera a.k.a. camera obscura

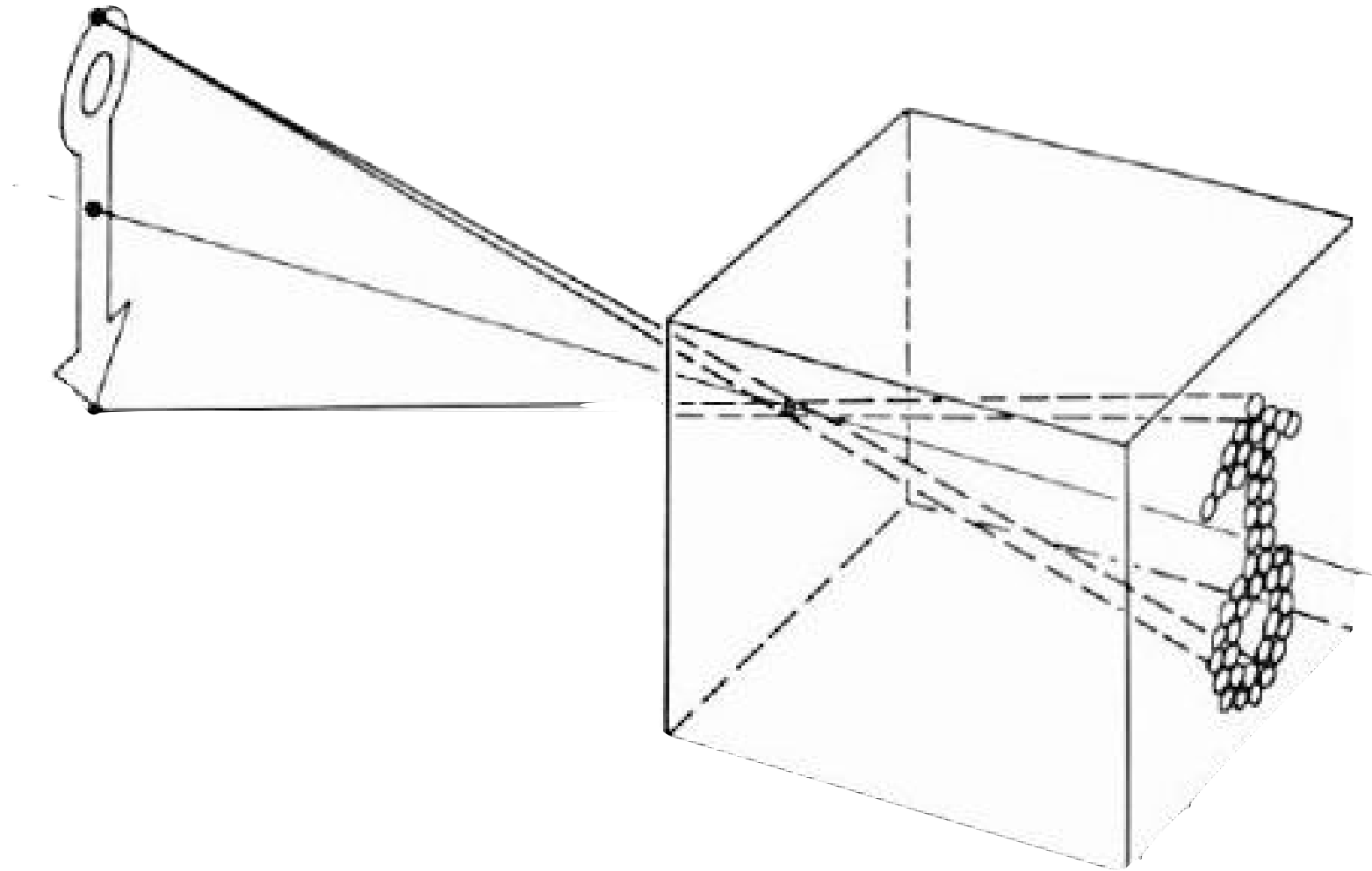

Pinhole camera a.k.a. camera obscura

First mention ...



Chinese philosopher Mozi
(470 to 390 BC)

First camera ...

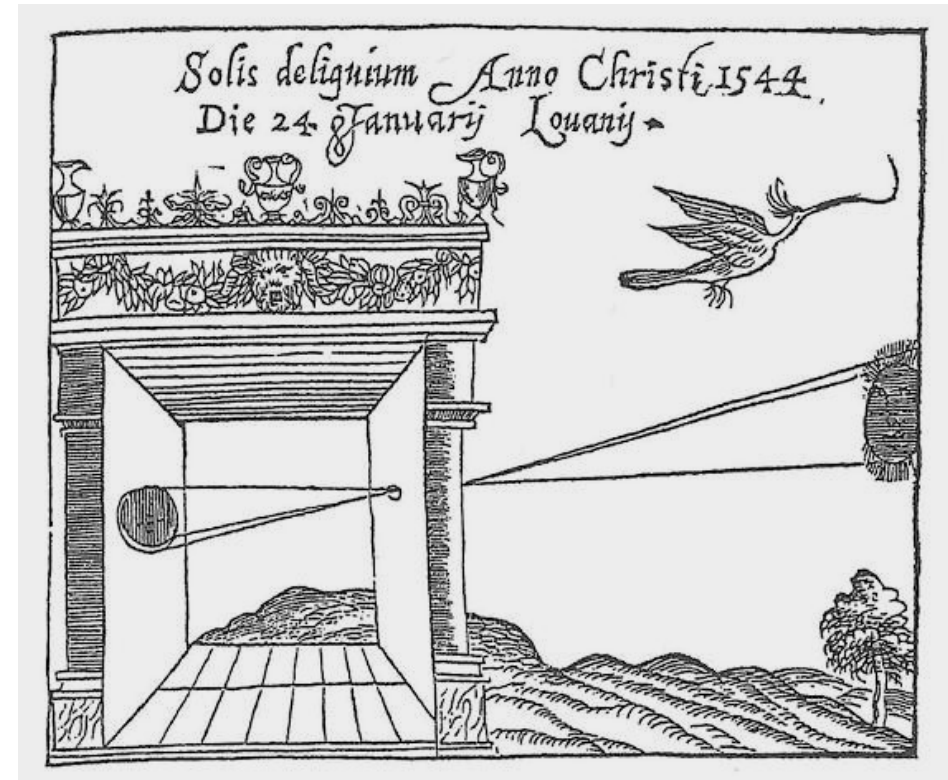

Greek philosopher Aristotle
(384 to 322 BC)

Pinhole camera terms

real-world
object



barrier (diaphragm)



pinhole
(aperture)



digital sensor
(CCD or CMOS)

Pinhole camera terms

real-world
object



barrier (diaphragm)



pinhole
(aperture)



camera center
(center of projection)

image plane



digital sensor
(CCD or CMOS)

Focal length

real-world
object

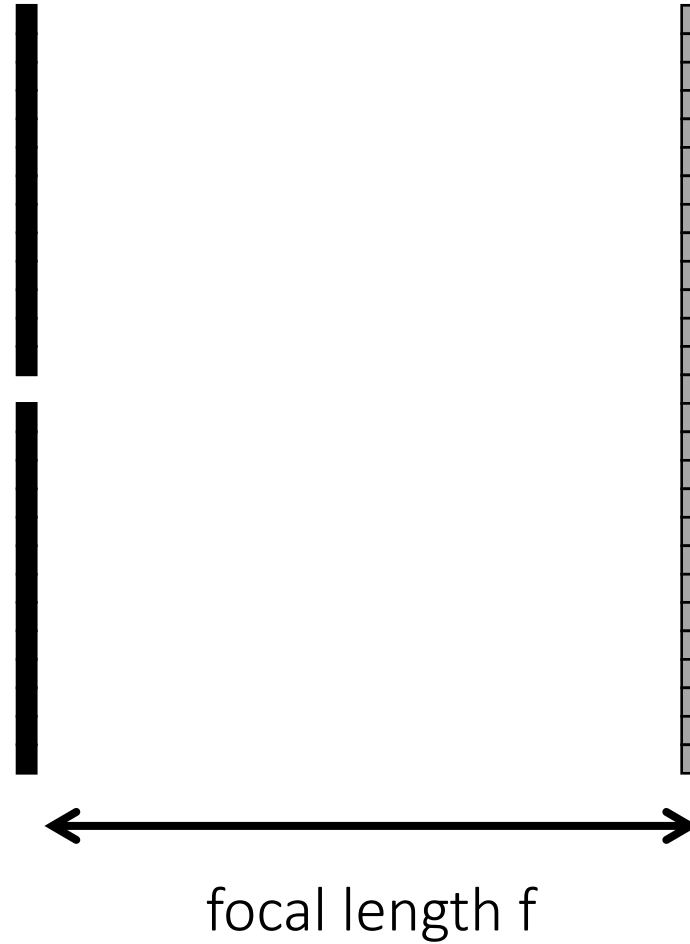

Focal length

What happens as we change the focal length?

real-world
object

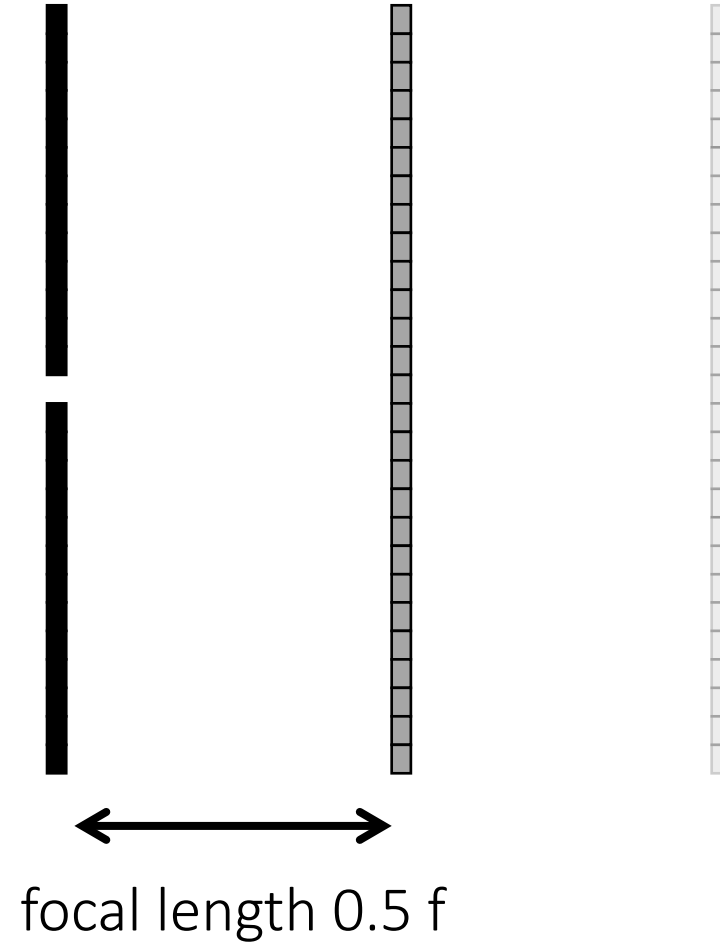

Focal length

What happens as we change the focal length?

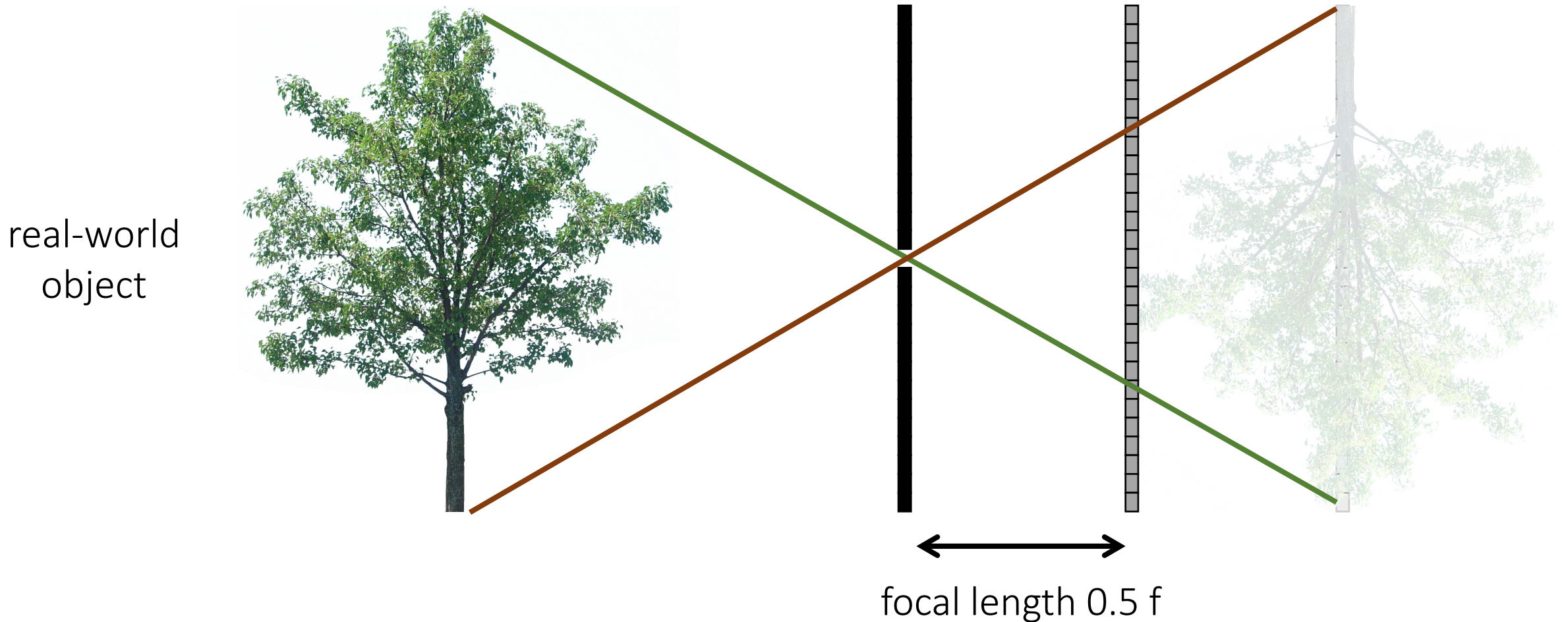

Focal length

What happens as we change the focal length?

object projection is half the size

real-world
object

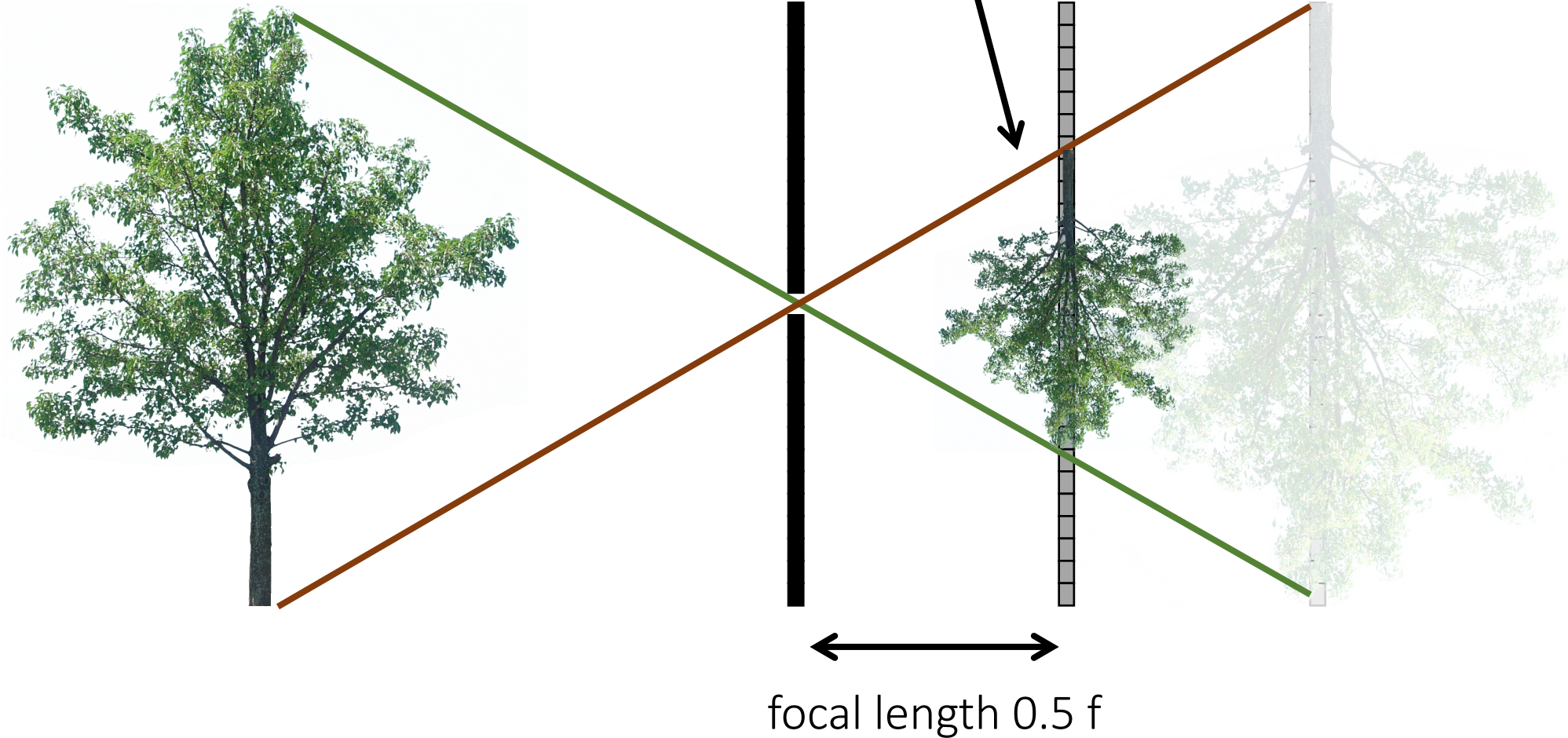

Pinhole size

real-world
object



pinhole
diameter



Ideal pinhole has infinitesimally small size

- In practice that is impossible.

Pinhole size

What happens as we change the pinhole diameter?

real-world
object



pinhole
diameter



Pinhole size

What happens as we change the pinhole diameter?

real-world
object

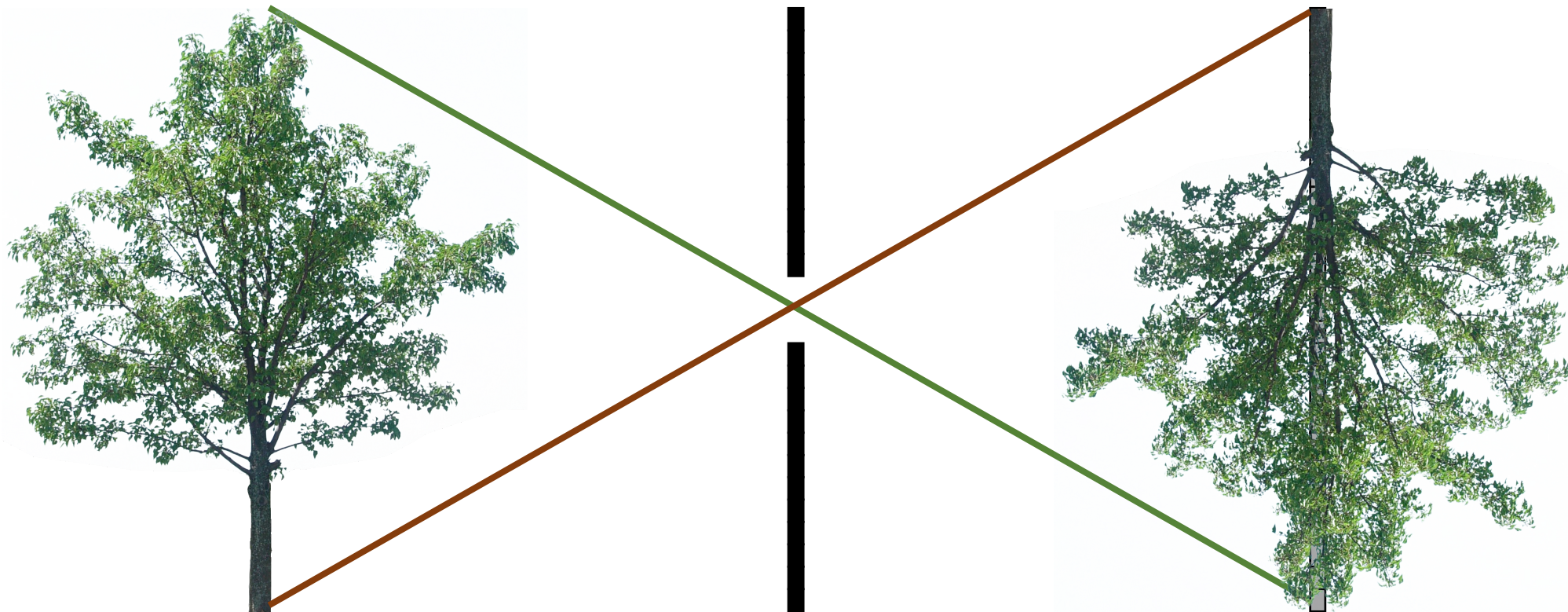

Pinhole size

What happens as we change the pinhole diameter?

real-world
object

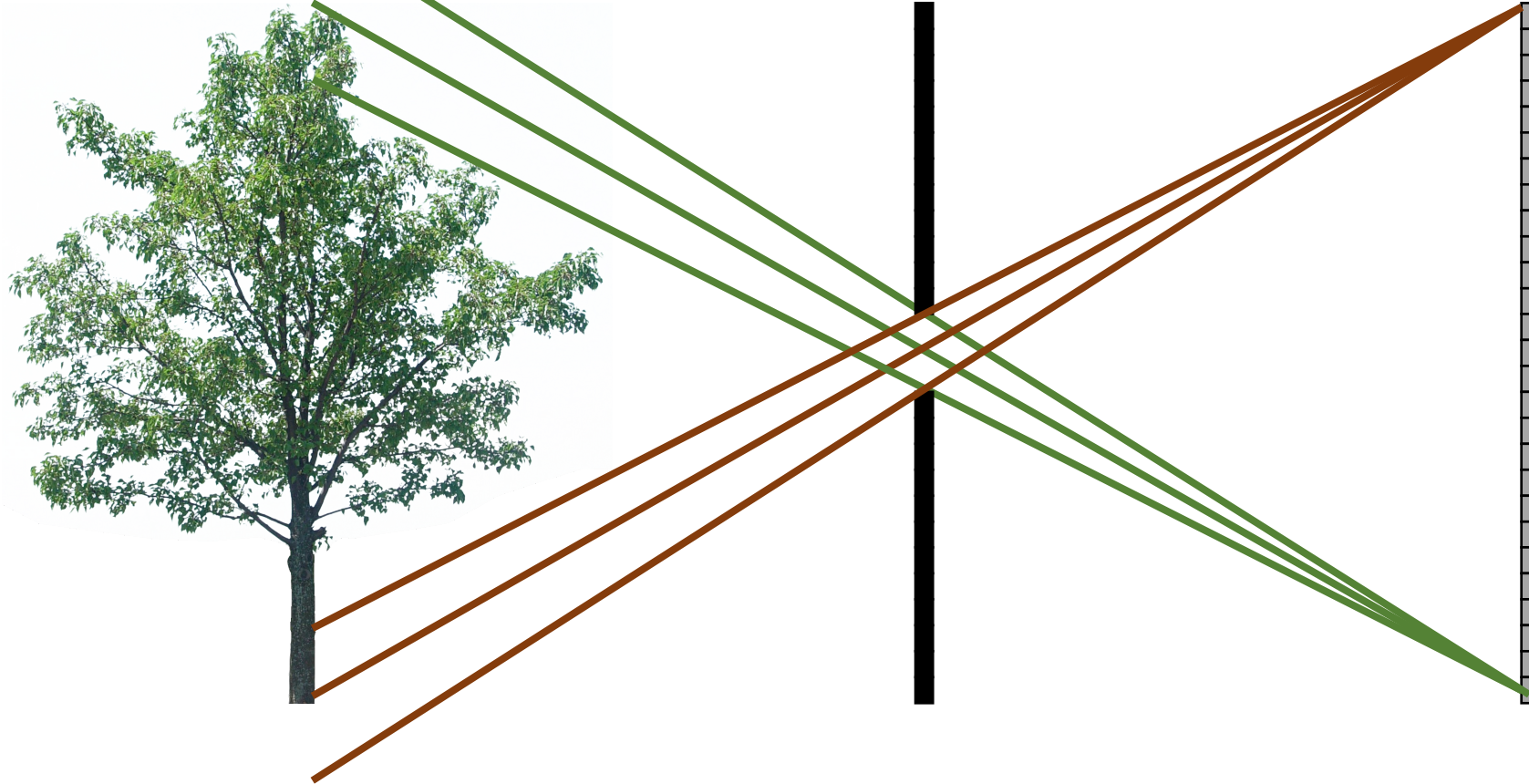

Pinhole size

What happens as we change the pinhole diameter?

object projection becomes blurrier

real-world
object

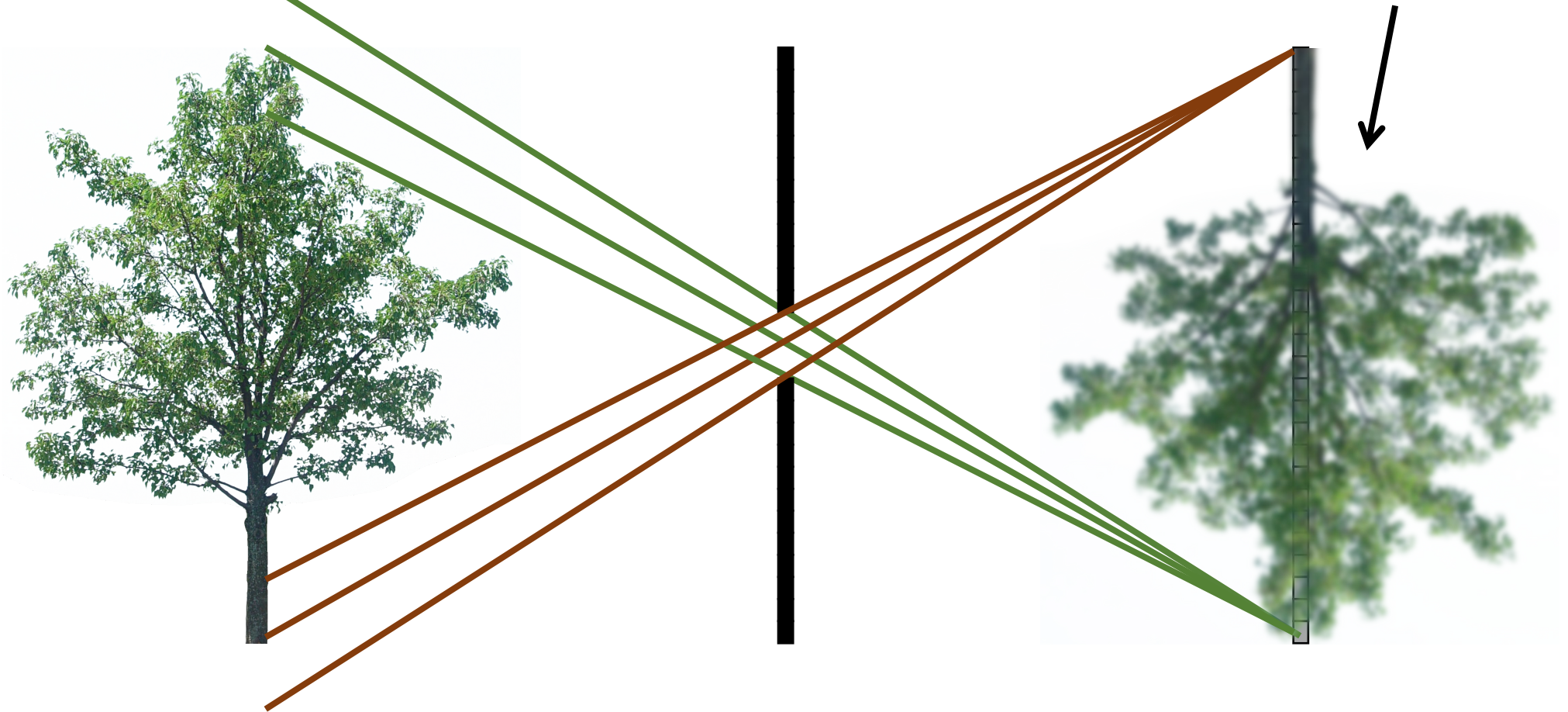

Pinhole size

What happens as we change the pinhole diameter?

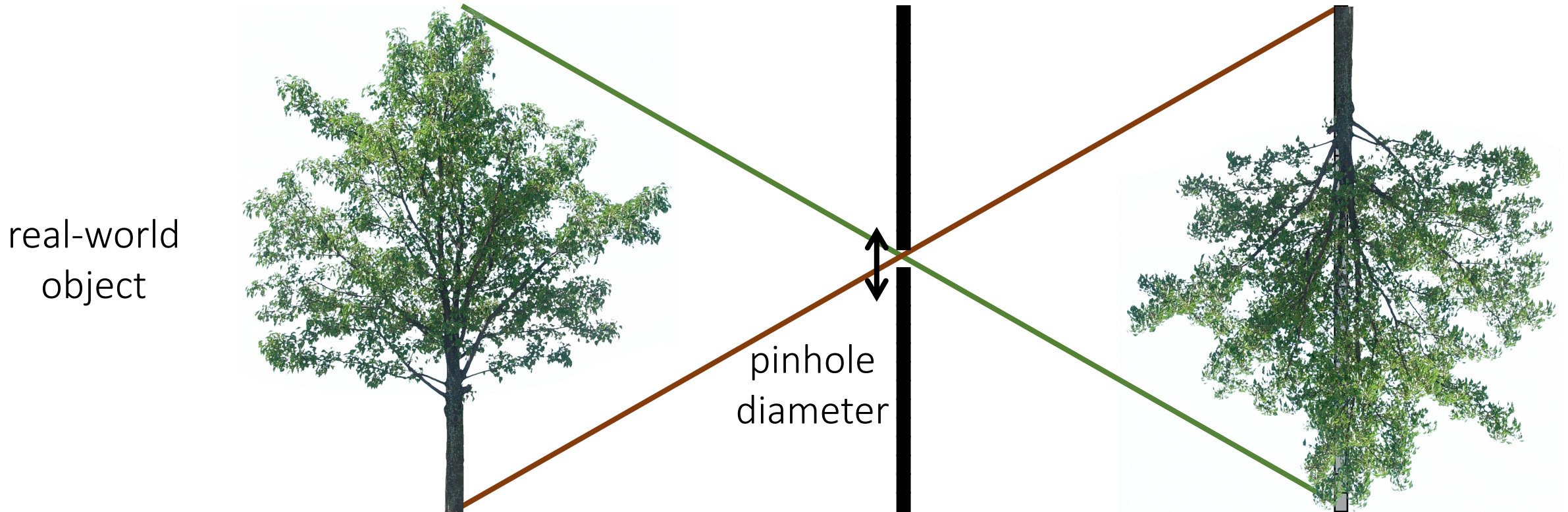

Will the image keep getting sharper the smaller we make the pinhole?

Diffraction limit

A consequence of the wave nature of light

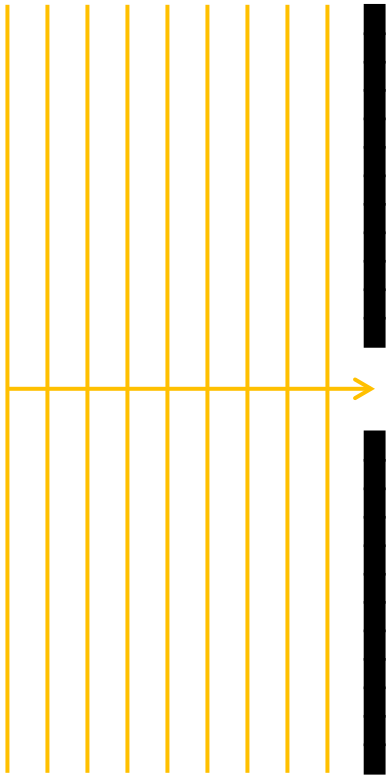

What do geometric optics predict will happen?

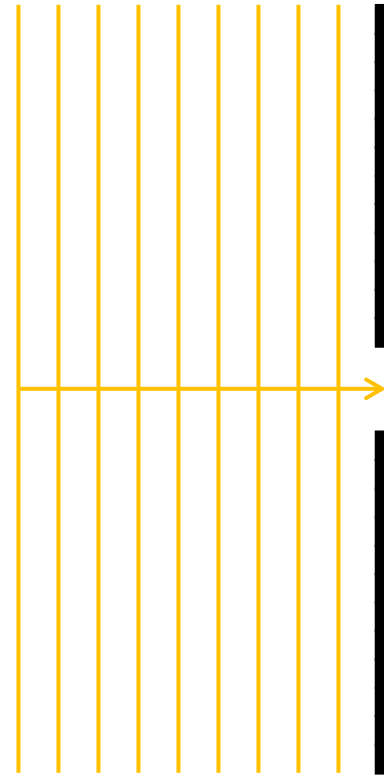

What do wave optics predict will happen?

Diffraction limit

A consequence of the wave nature of light

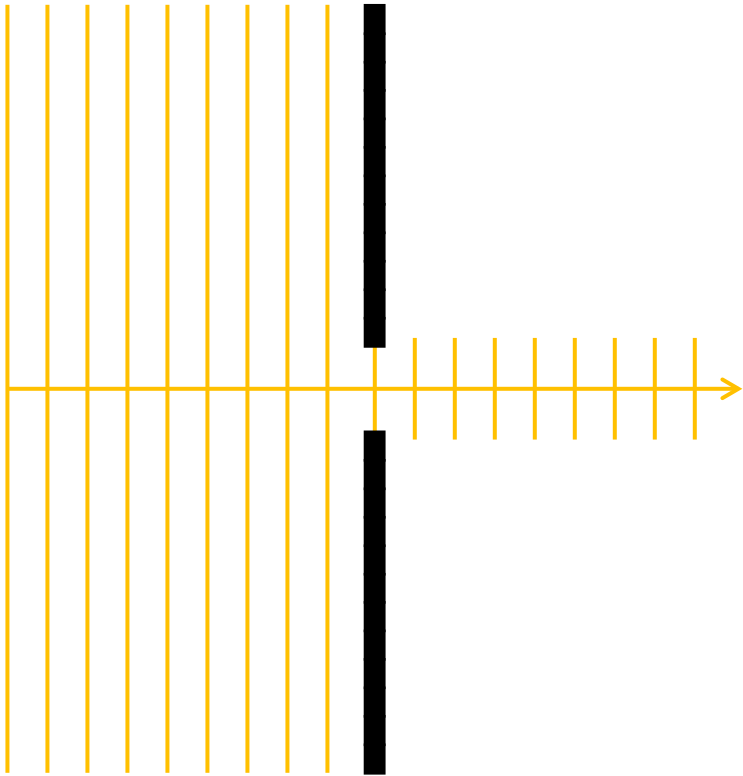

What do geometric optics predict will happen?

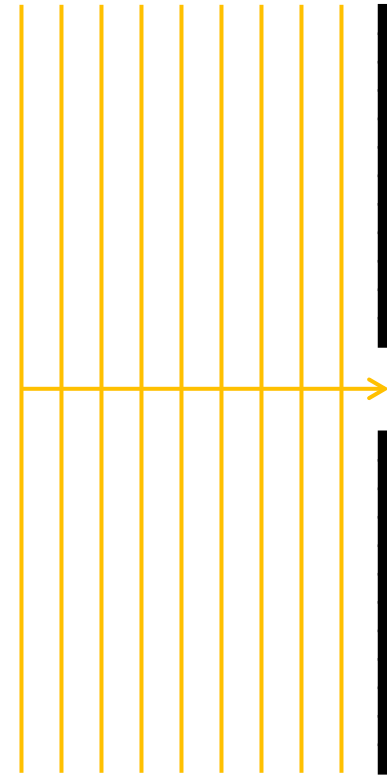

What do wave optics predict will happen?

Diffraction limit

A consequence of the wave nature of light

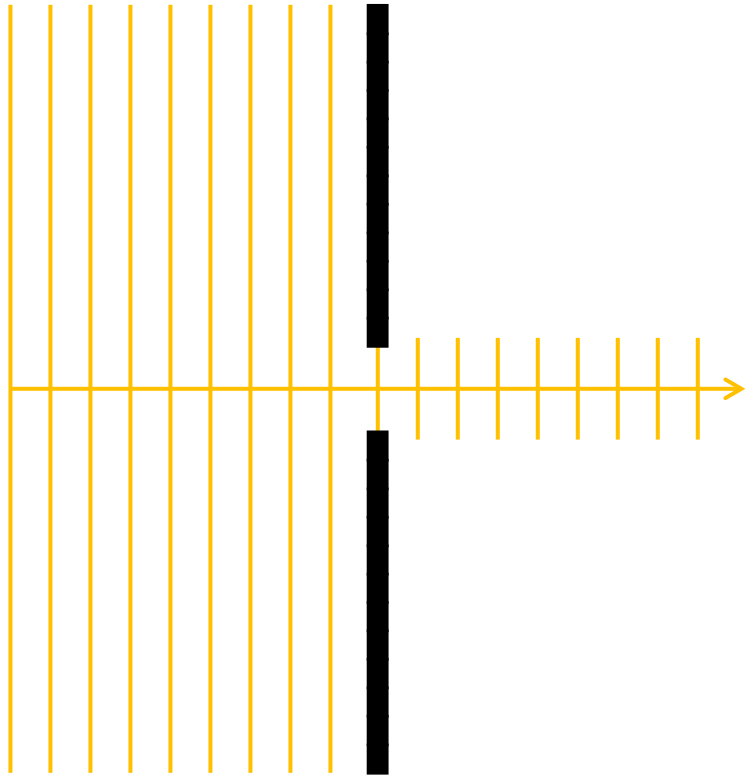

What do geometric optics predict will happen?

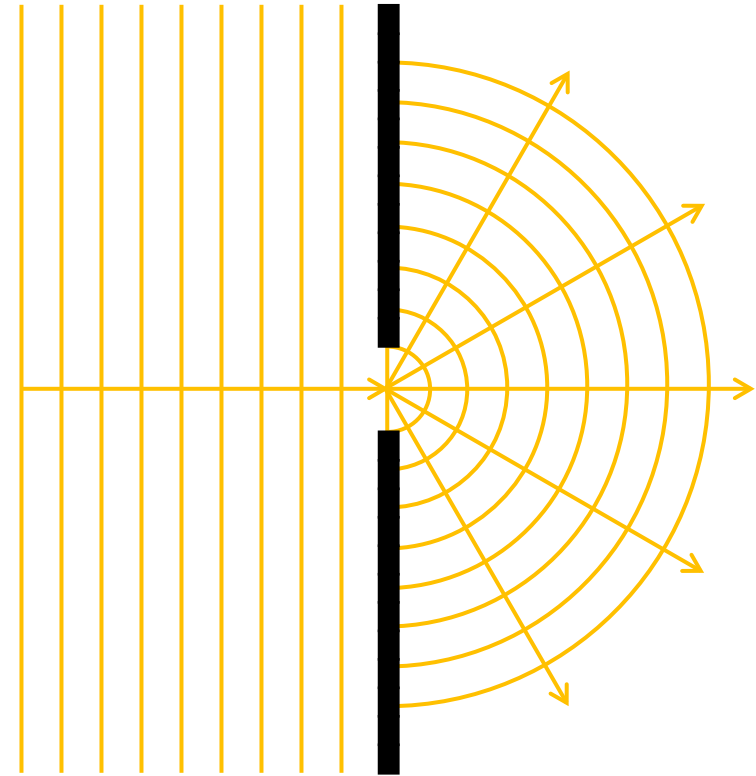

What do wave optics predict will happen?

Diffraction limit

Diffraction pattern = Fourier transform of the pinhole.

- Smaller pinhole means bigger Fourier spectrum.
- Smaller pinhole means more diffraction.

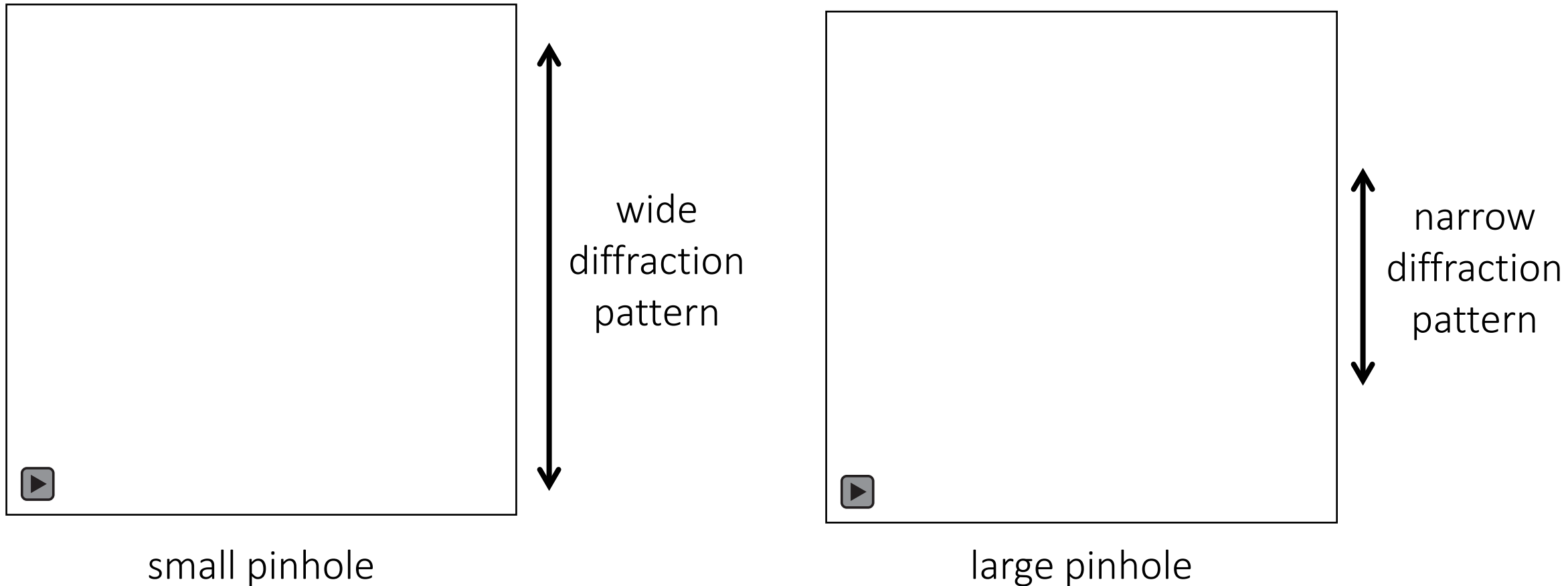

What about light efficiency?

real-world
object



pinhole
diameter

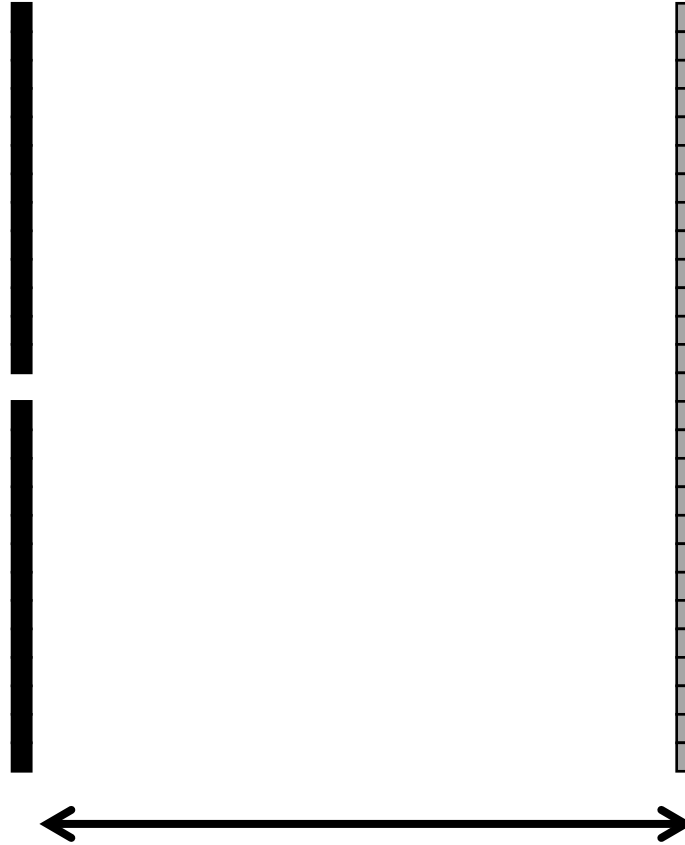

focal length f

- What is the effect of doubling the pinhole diameter?
- What is the effect of doubling the focal length?

What about light efficiency?

real-world
object



pinhole
diameter

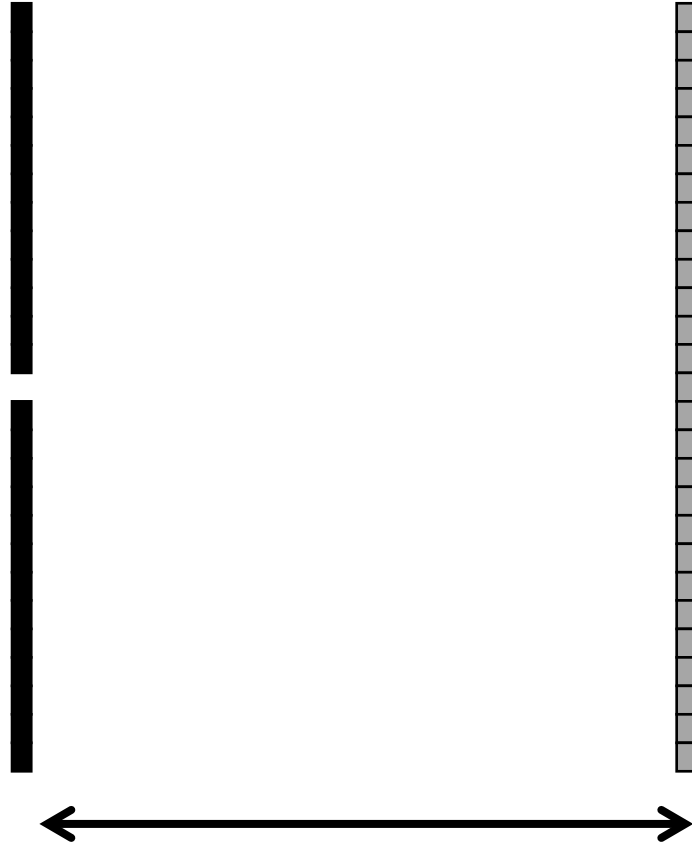

focal length f

- 2x pinhole diameter \rightarrow 4x light
- 2x focal length \rightarrow $\frac{1}{4}$ x light

Some terminology notes

A “stop” is a change in camera settings that changes amount of light by a factor of 2

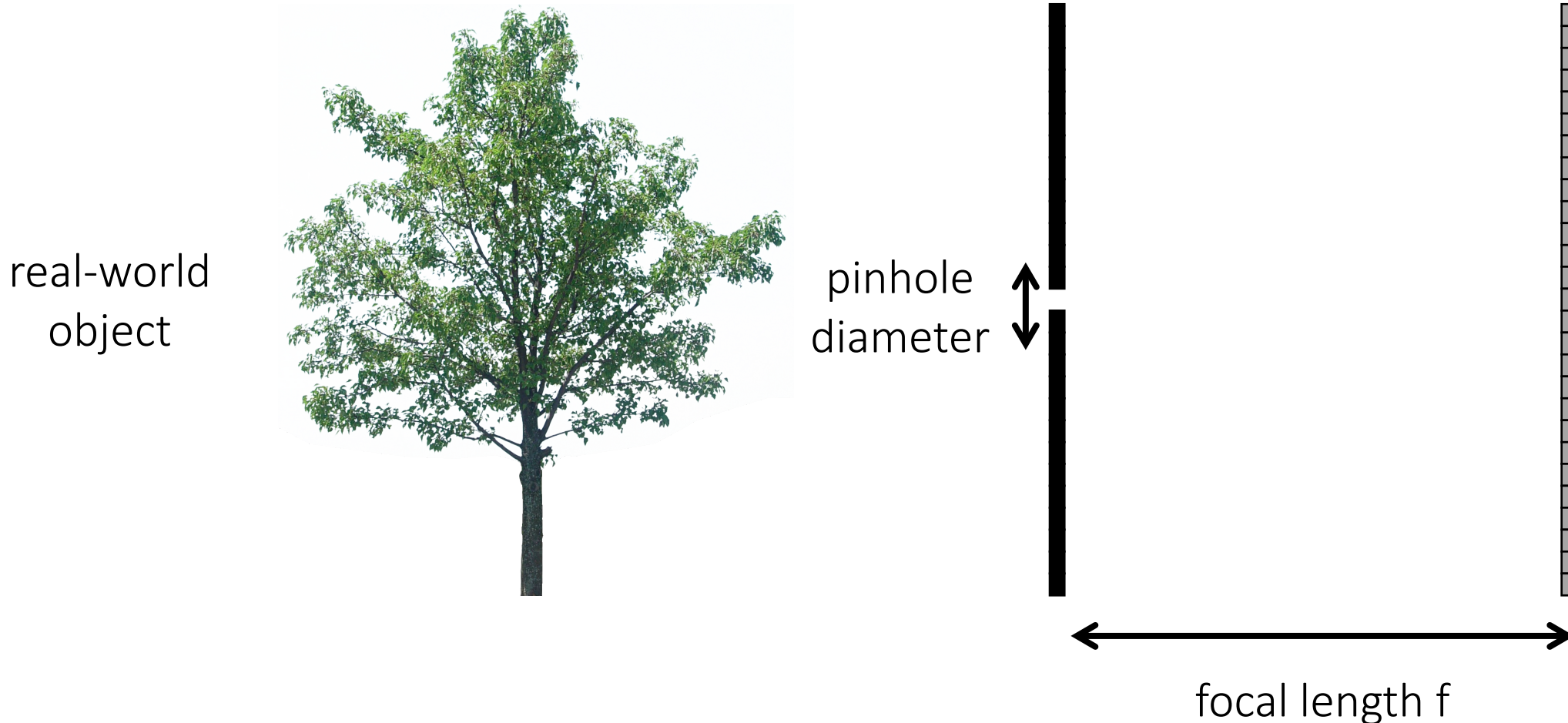

The “f-number” is the ratio: focal length / pinhole diameter

Accidental pinholes





What does this image say about the world outside?



Accidental pinhole camera



Antonio Torralba, William T. Freeman
Computer Science and Artificial Intelligence Laboratory (CSAIL)
MIT
torralba@mit.edu, billf@mit.edu

Accidental pinhole camera

projected pattern on the wall



upside down



window with smaller gap



view outside window

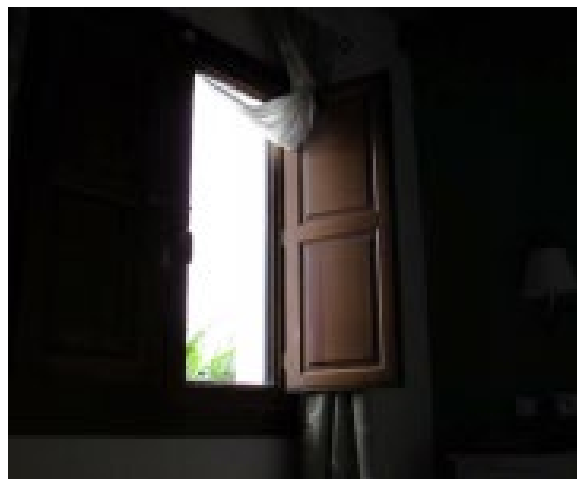

window is an
aperture

Accidental pinspeck camera

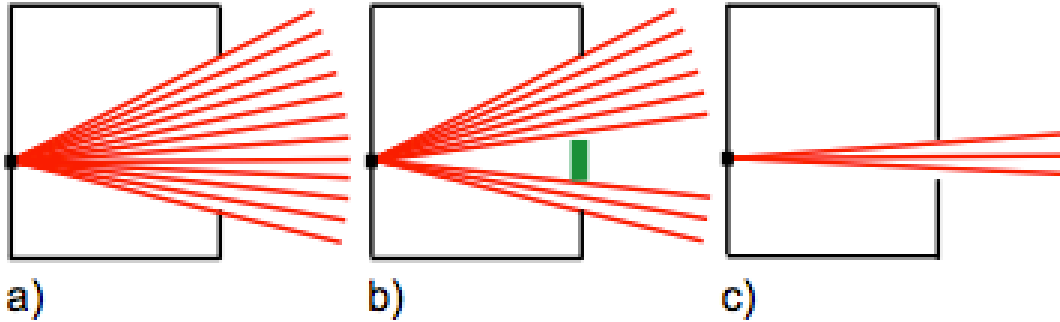

a)



b)

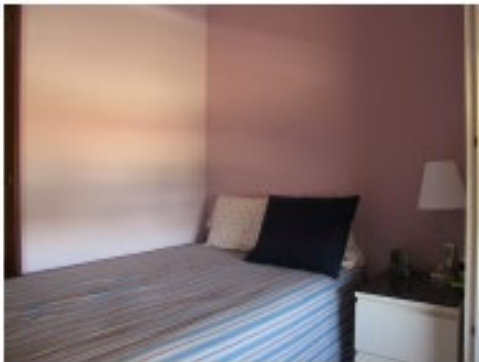

c)

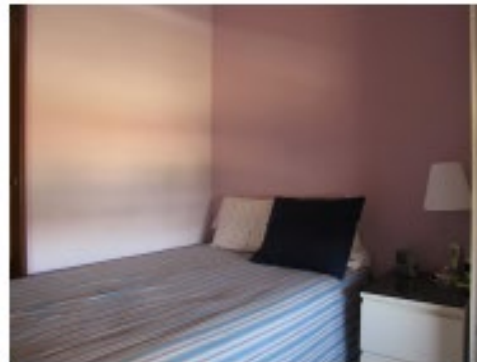

d)

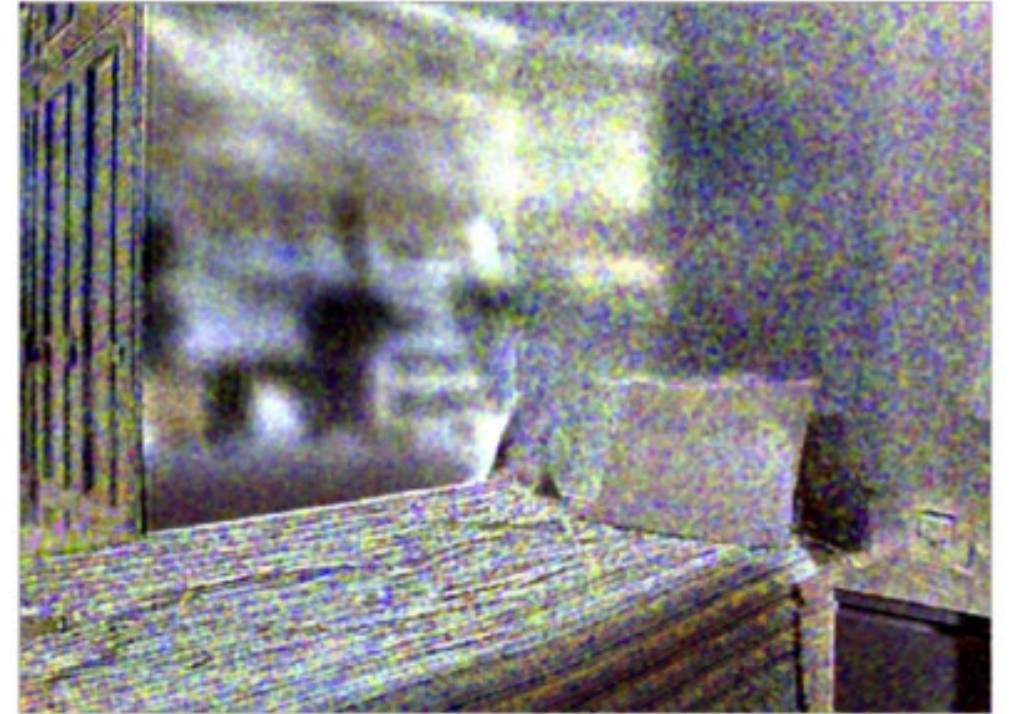

a) Difference image



b) Difference upside down



c) True outdoor view

Pinhole camera trade-off

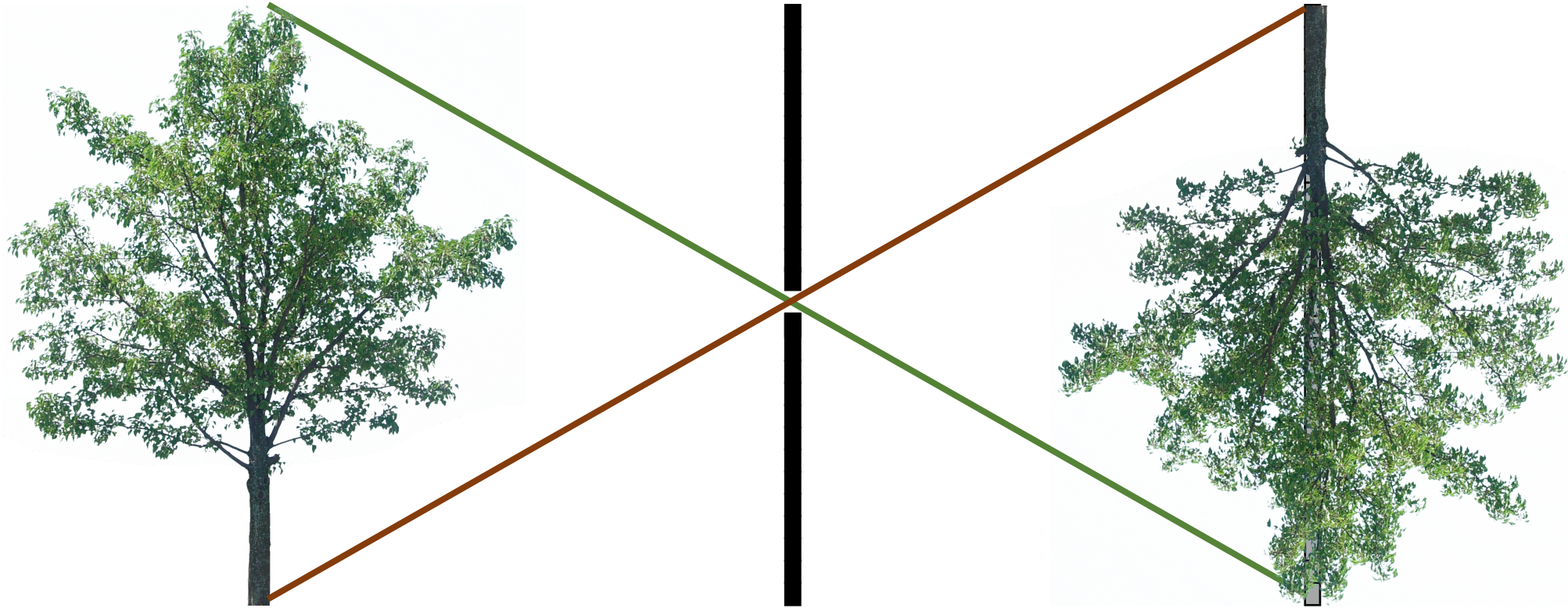

Small (ideal) pinhole:

1. Image is sharp.
2. Signal-to-noise ratio is low.

Pinhole camera trade-off

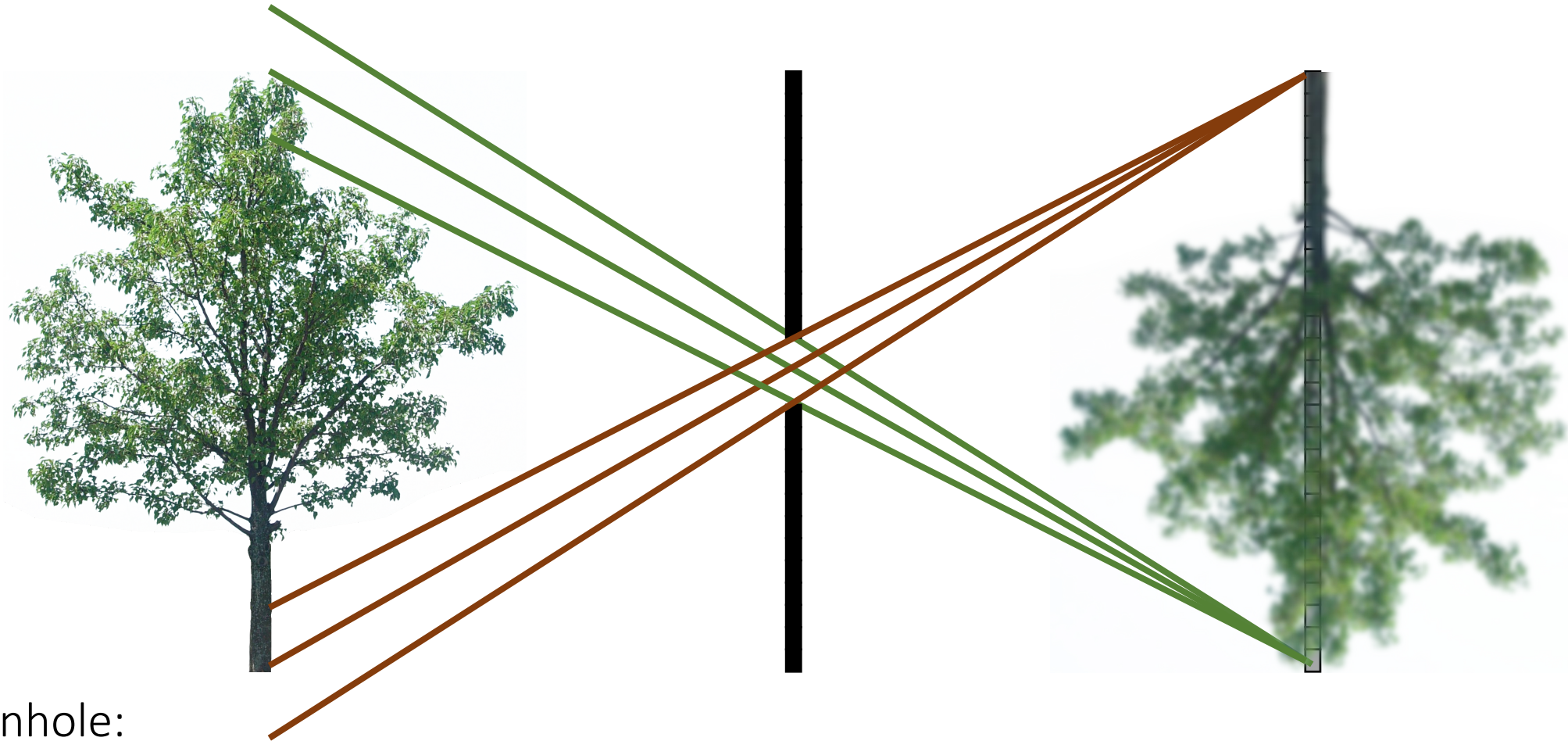

Large pinhole:

1. Image is blurry.
2. Signal-to-noise ratio is high.

Can we get best of both worlds?

Almost, by using lenses

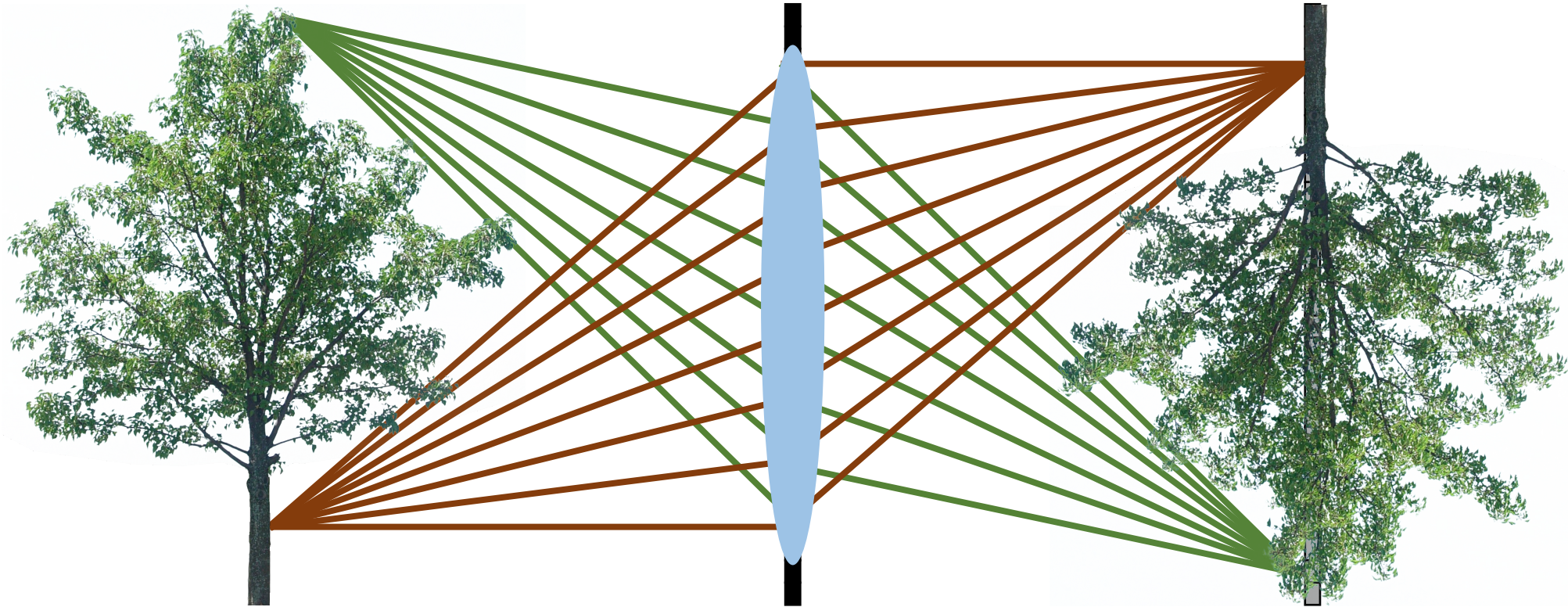

Lenses map “bundles” of rays from points on the scene to the sensor.

How does this mapping work exactly?

Lens (very) basics

What is a lens?

A piece of glass manufactured to have a specific shape

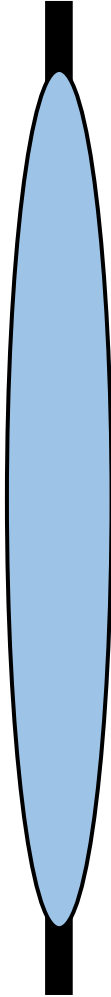

What is a lens?

A piece of glass manufactured to have a specific shape

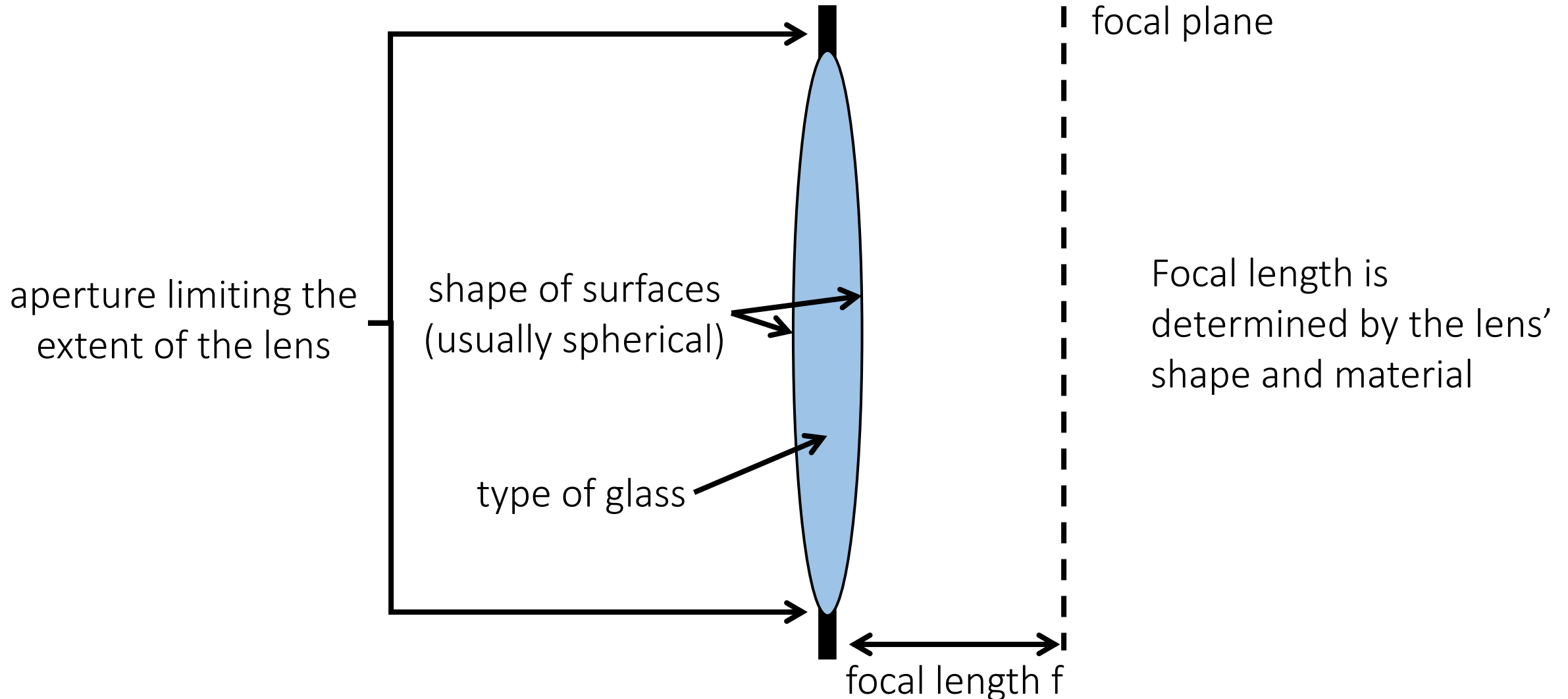

The lens on your camera



How does a lens work?

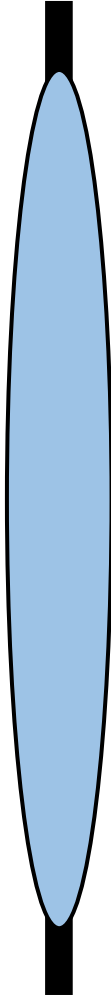

Refraction

Refraction is the bending of rays of light when they move from one material to another

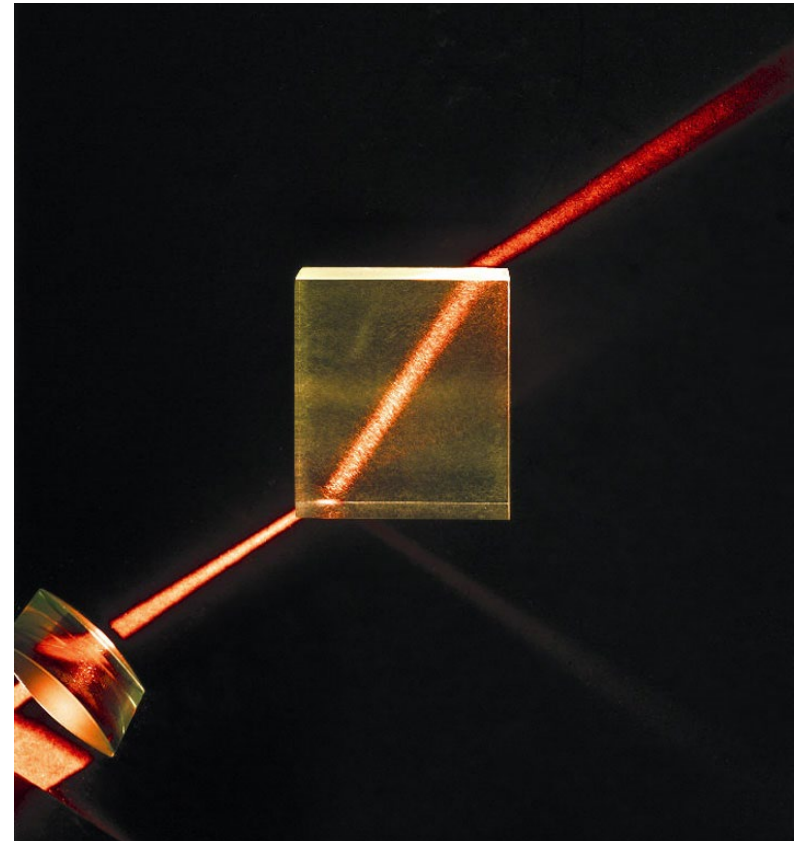
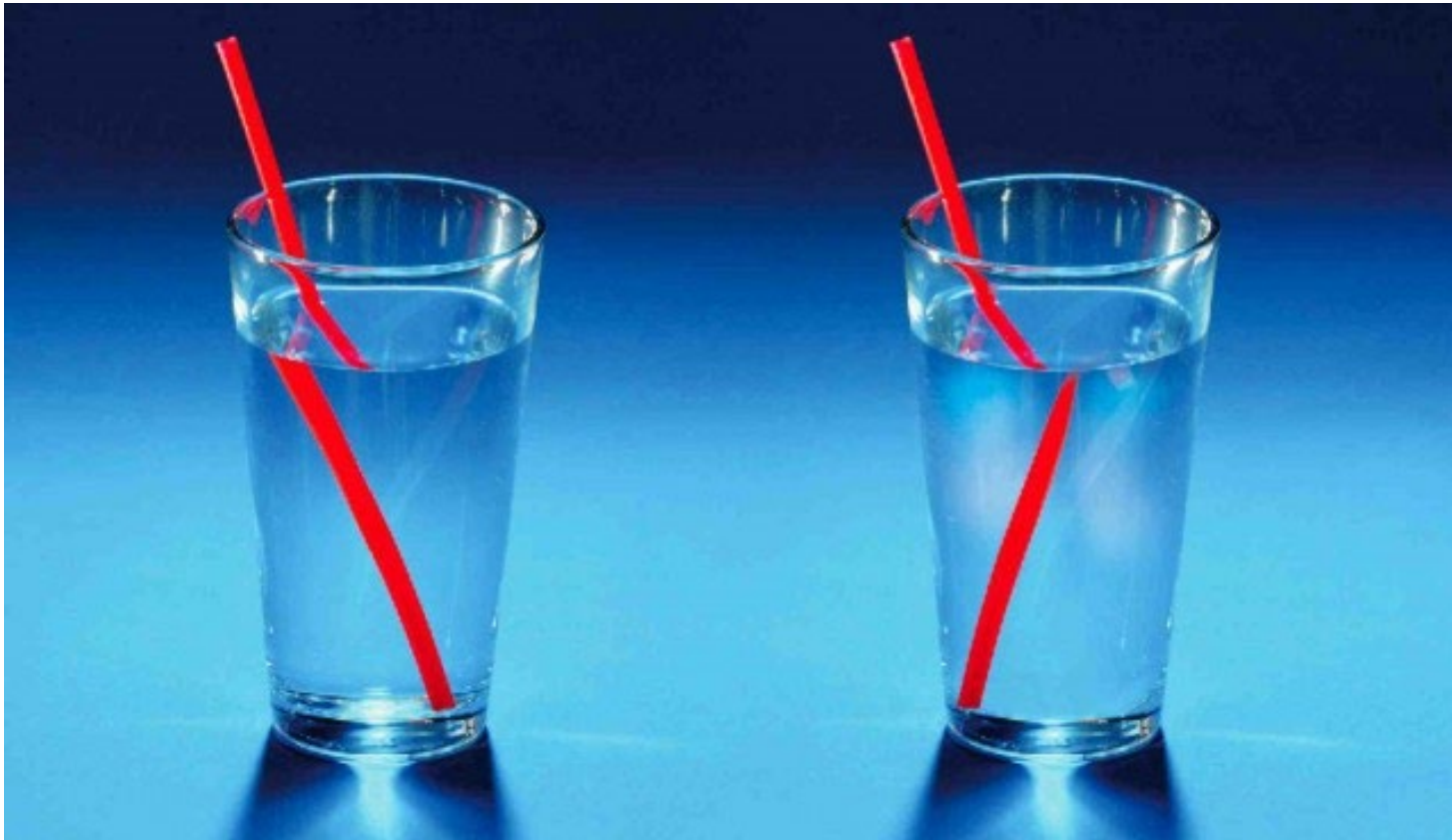

How does a lens work?

Lenses are designed so that their refraction makes light rays bend in a very specific way.

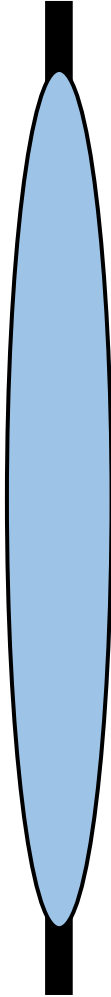

The thin lens model

Thin lens model

Simplification of geometric optics for well-designed lenses.



Thin lens model

Simplification of geometric optics for well-designed lenses.

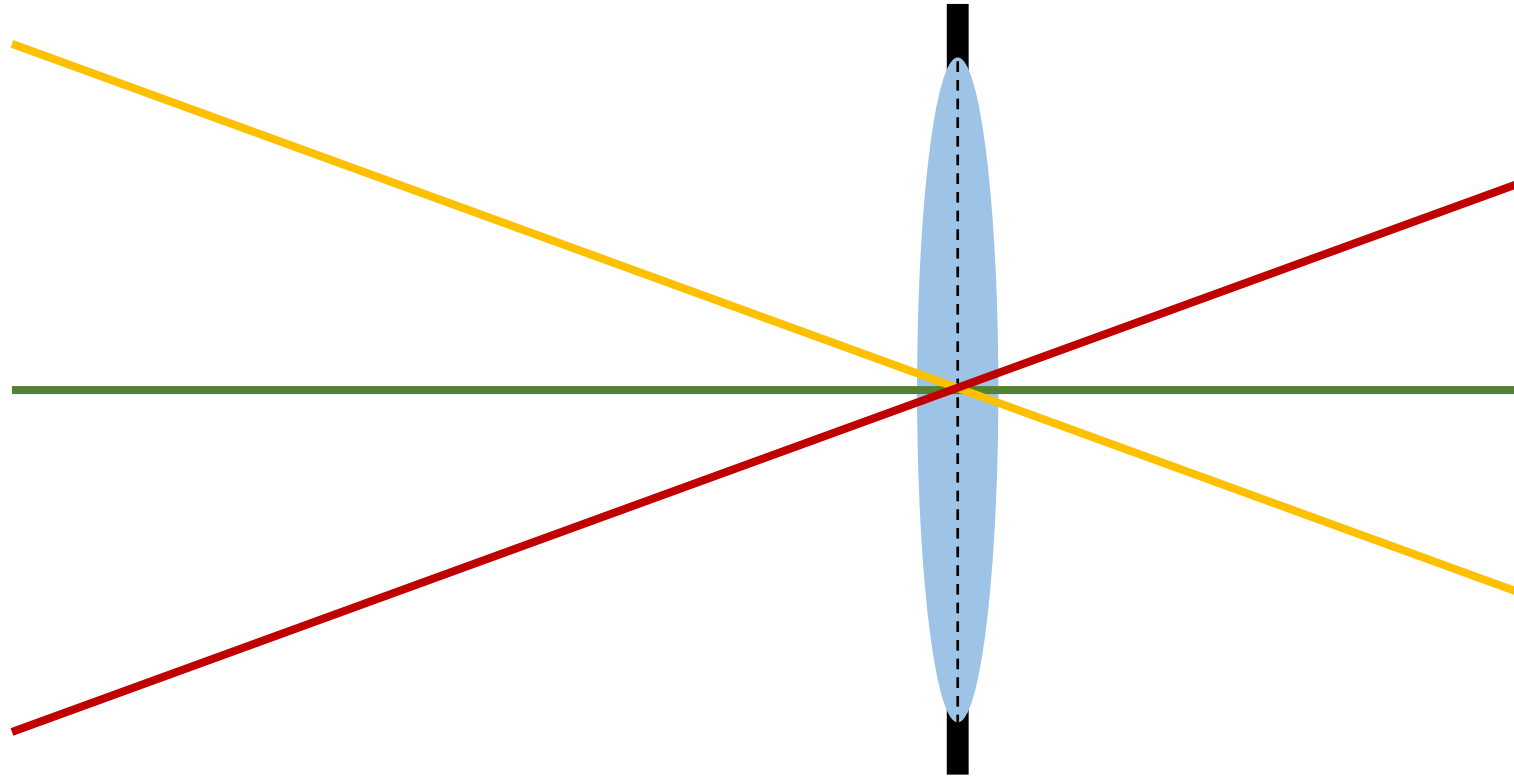

Two assumptions:

1. Rays passing through lens center are unaffected.

Thin lens model

Simplification of geometric optics for well-designed lenses.

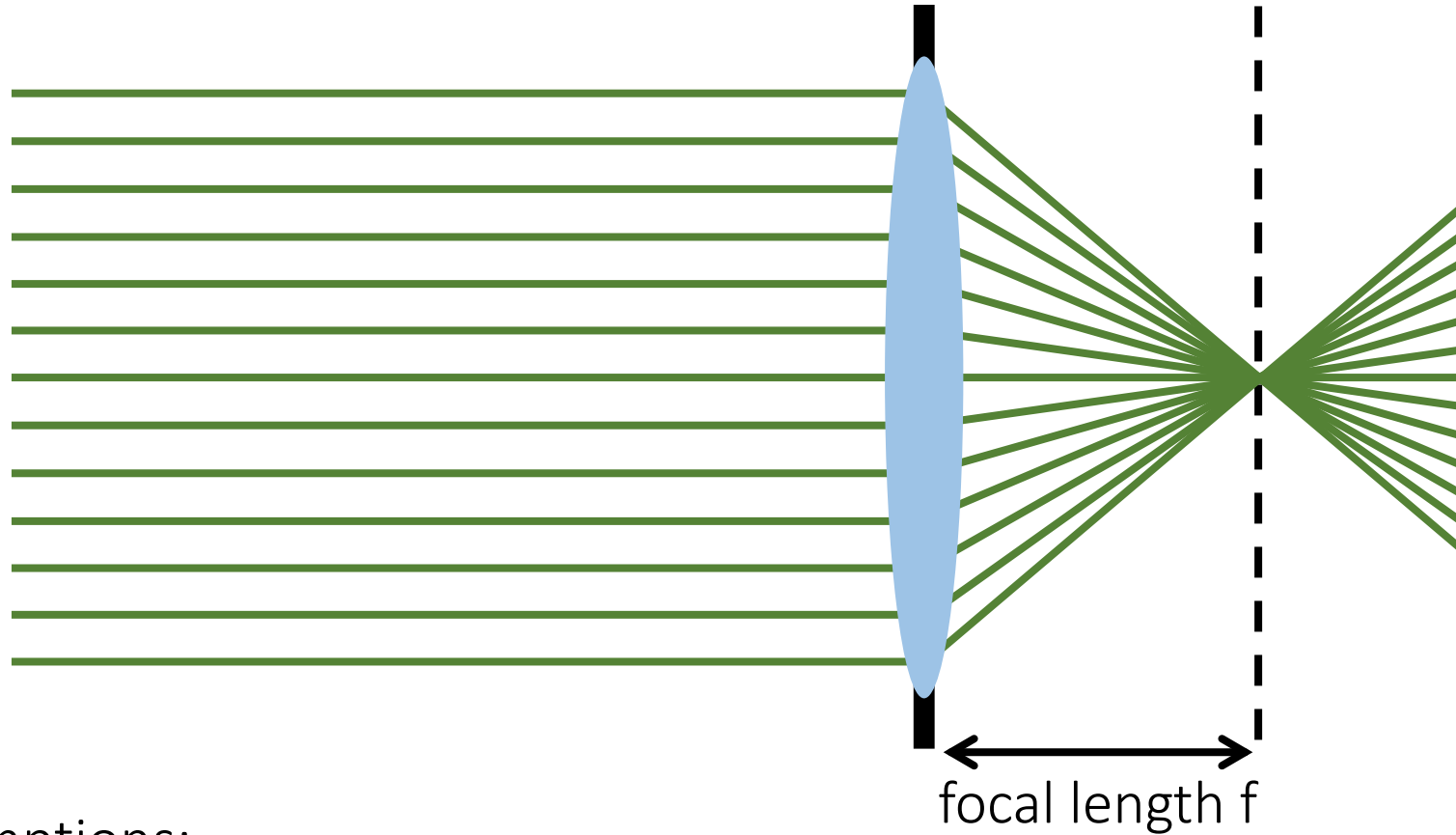

Two assumptions:

1. Rays passing through lens center are unaffected.
2. Parallel rays converge to a single point located on focal plane.

Thin lens model

Simplification of geometric optics for well-designed lenses.

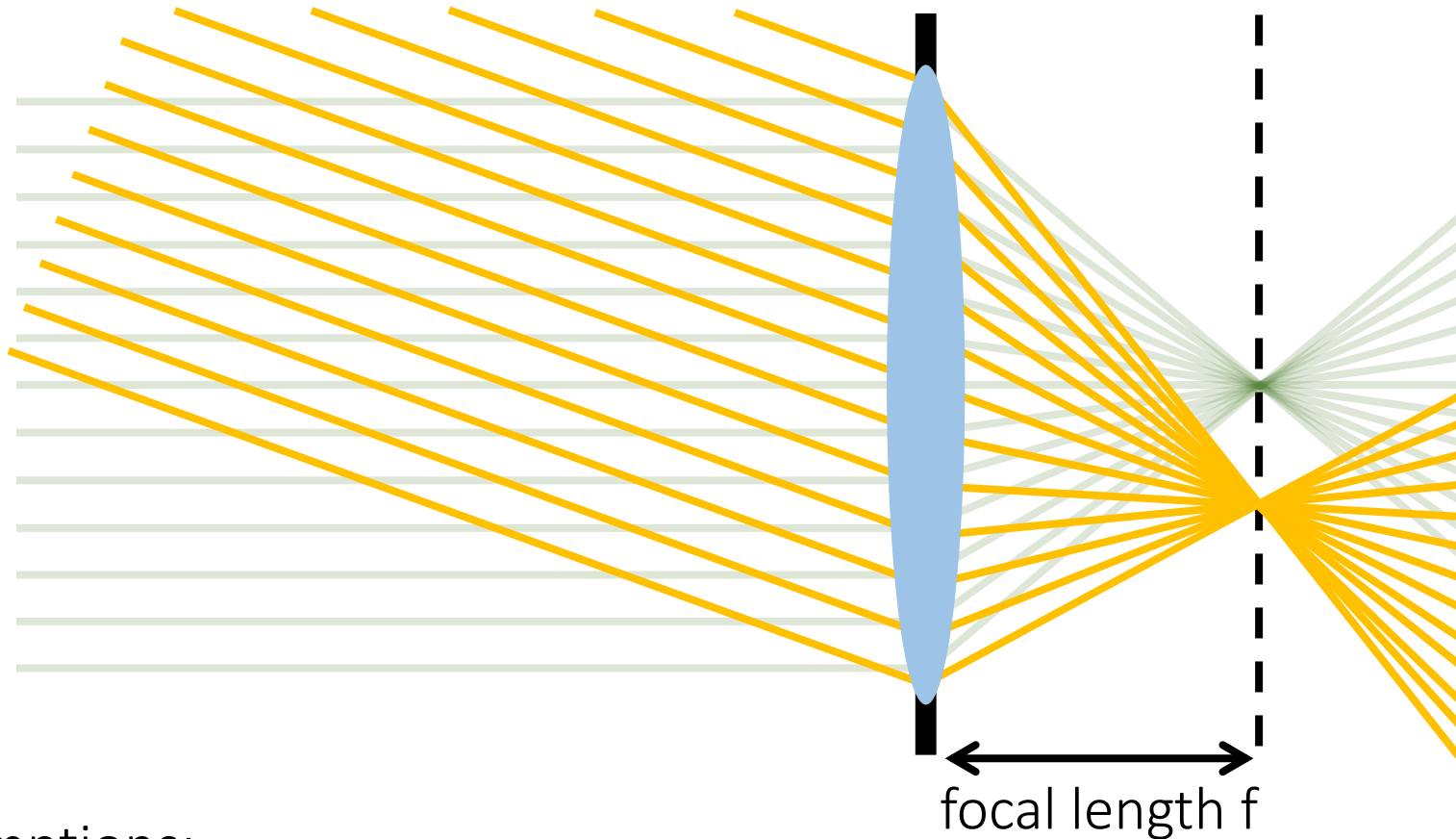

Two assumptions:

1. Rays passing through lens center are unaffected.
2. Parallel rays converge to a single point located on focal plane.

Thin lens model

Simplification of geometric optics for well-designed lenses.

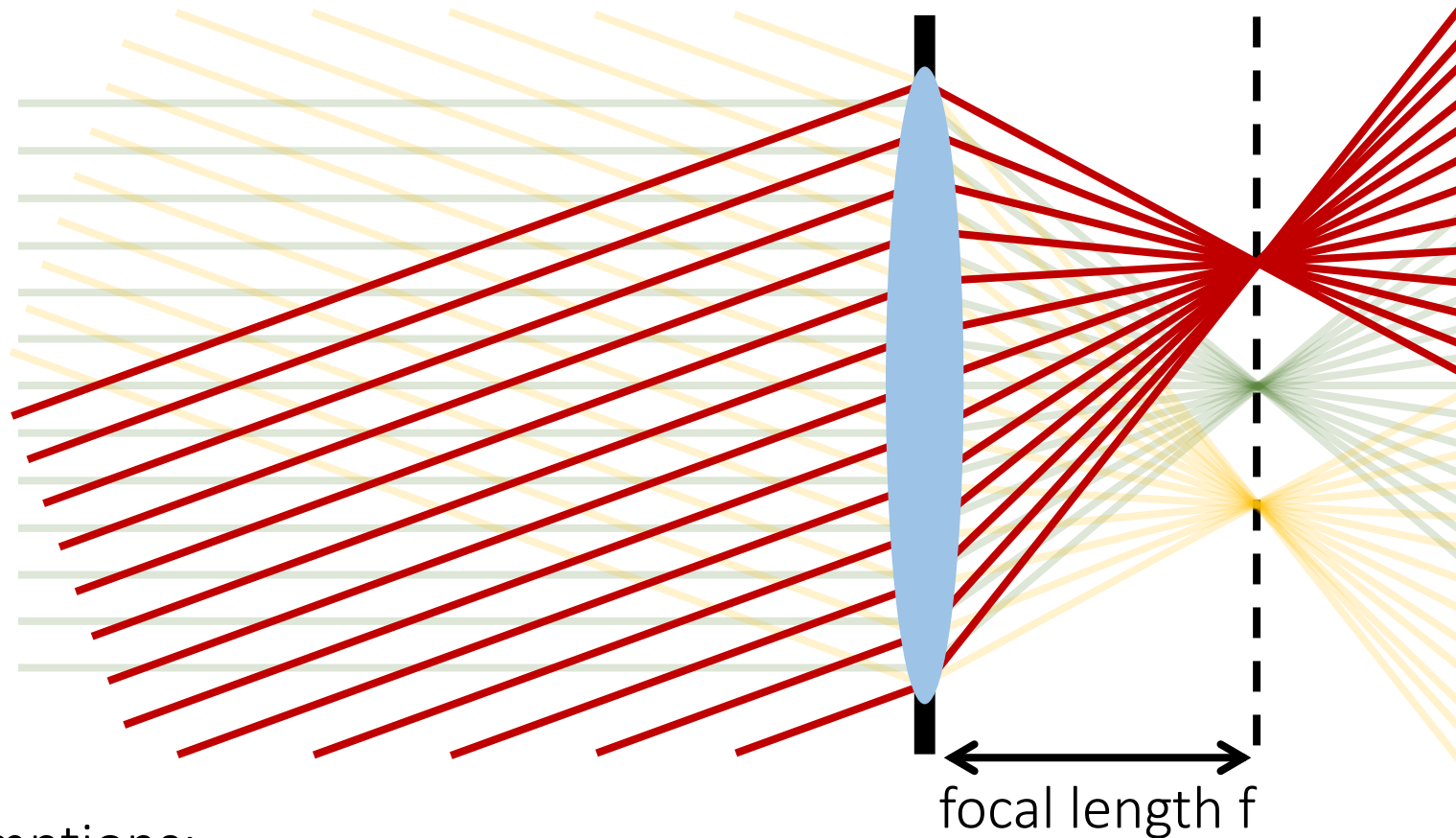

Two assumptions:

1. Rays passing through lens center are unaffected.
2. Parallel rays converge to a single point located on focal plane.

Tracing rays through a thin lens

Consider an object emitting a bundle of rays. How do they propagate through the lens?

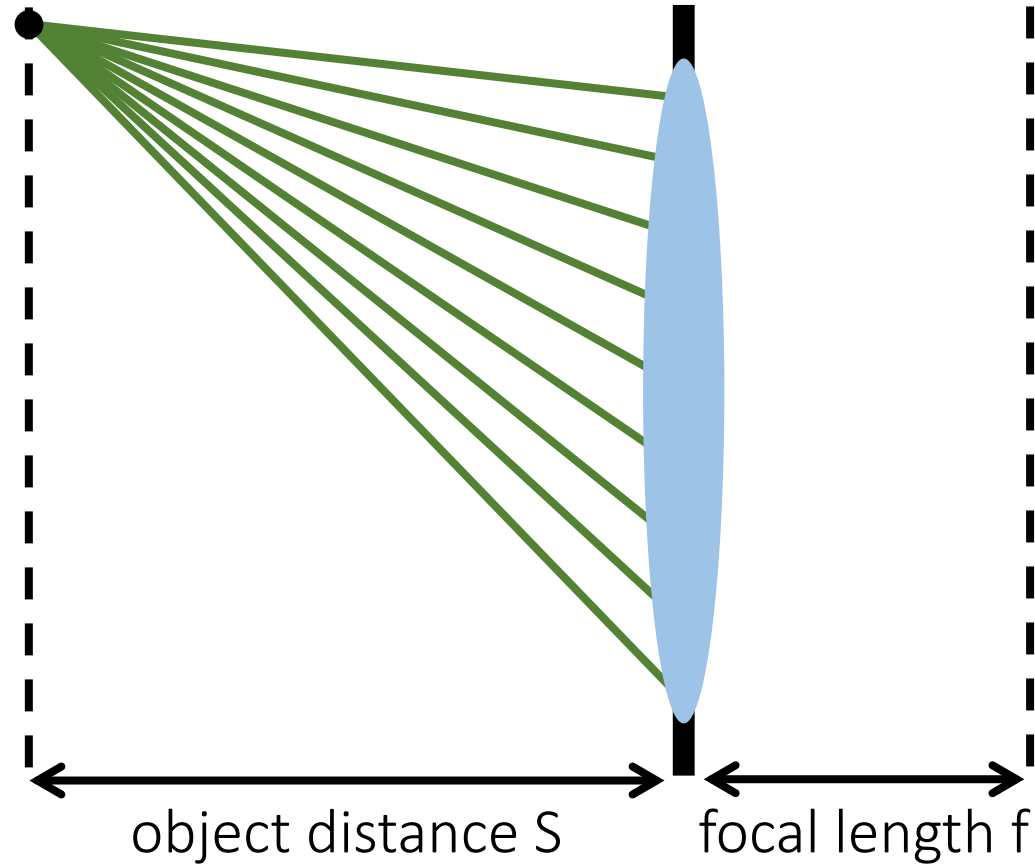

Tracing rays through a thin lens

Consider an object emitting a bundle of rays. How do they propagate through the lens?

1. Trace rays through lens center.

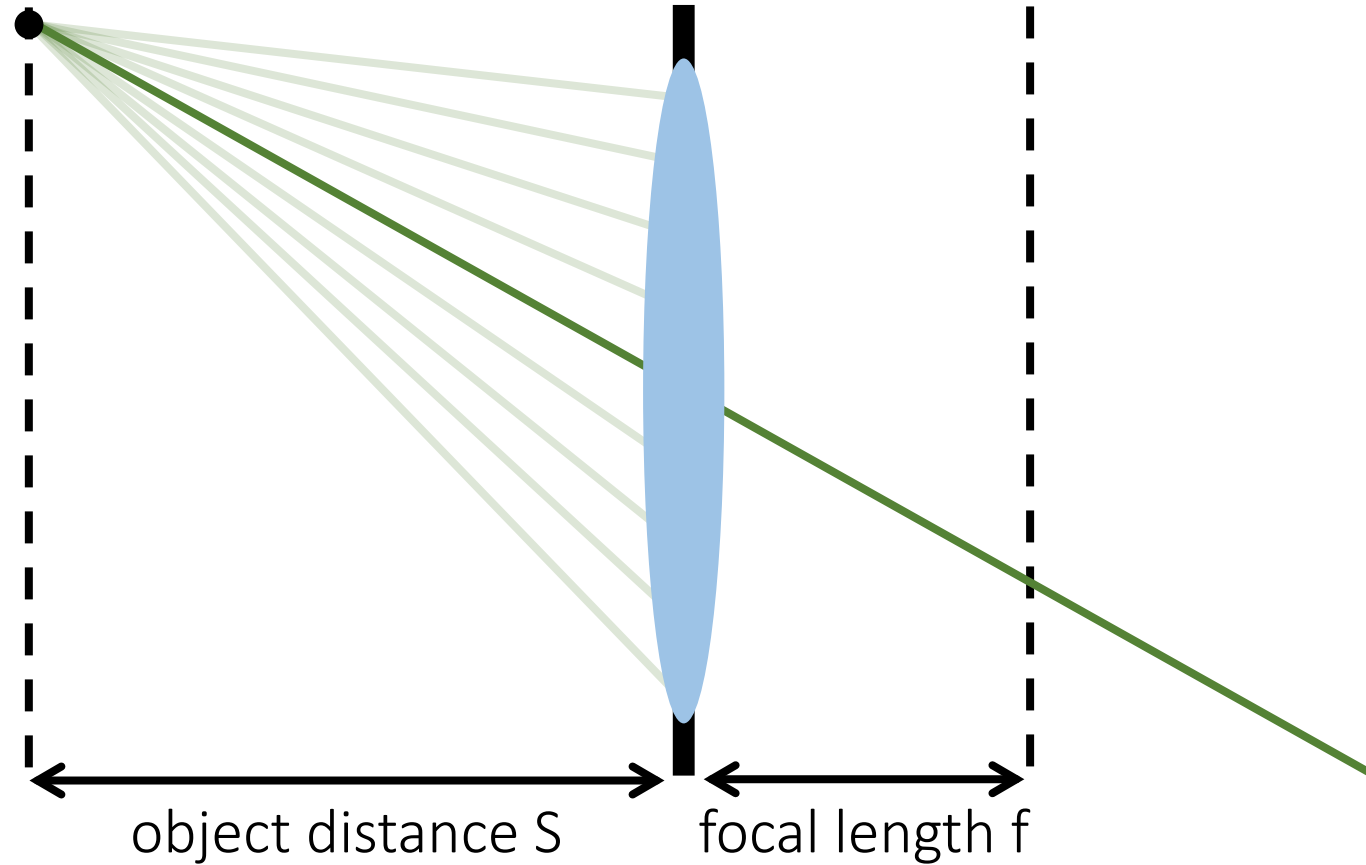

Tracing rays through a thin lens

Consider an object emitting a bundle of rays. How do they propagate through the lens?

1. Trace rays through lens center.
2. For all other rays:

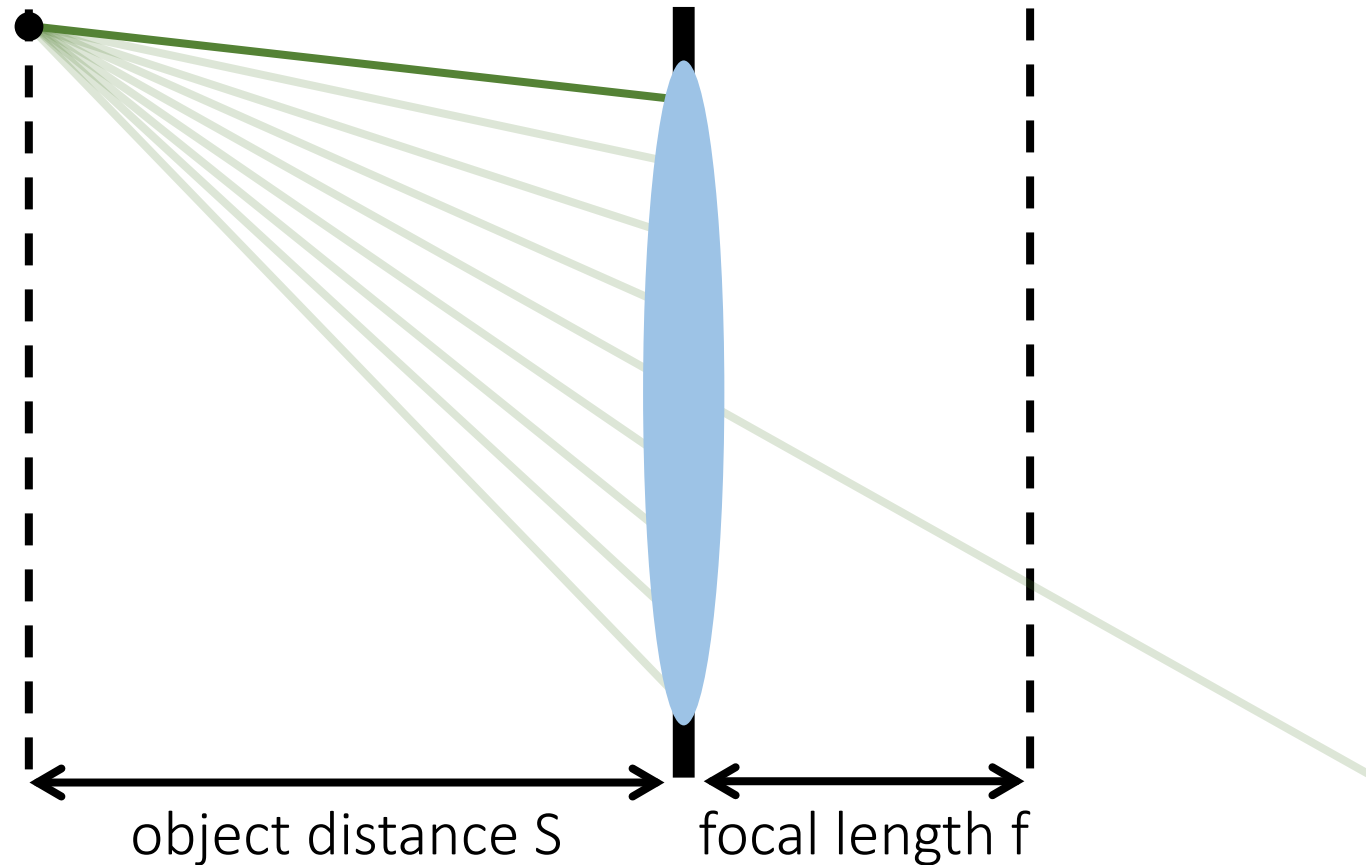

Tracing rays through a thin lens

Consider an object emitting a bundle of rays. How do they propagate through the lens?

1. Trace rays through lens center.
2. For all other rays:
 - a. Trace their parallel through lens center.

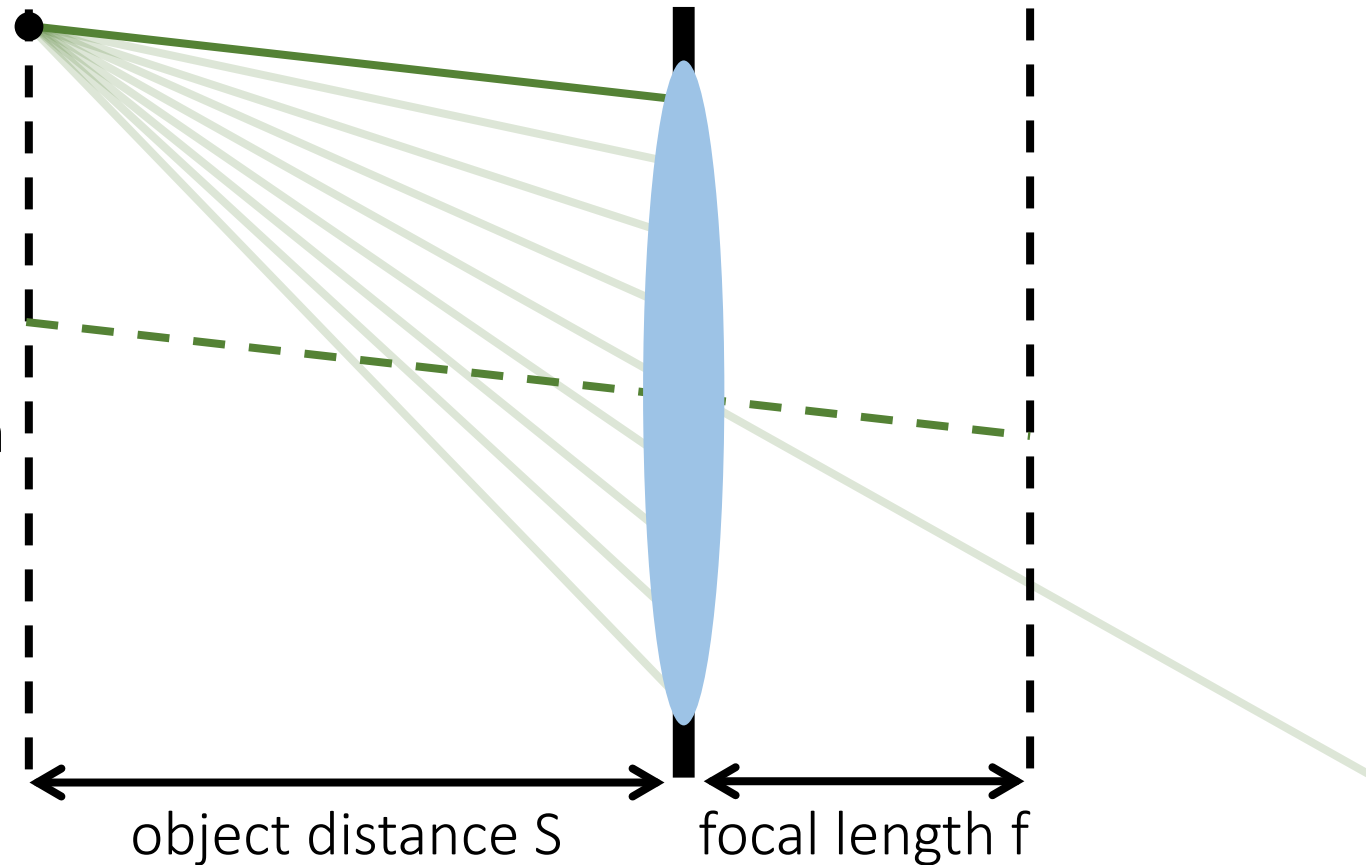

Tracing rays through a thin lens

Consider an object emitting a bundle of rays. How do they propagate through the lens?

1. Trace rays through lens center.
2. For all other rays:
 - a. Trace their parallel through lens center.
 - b. Connect on focal plane.

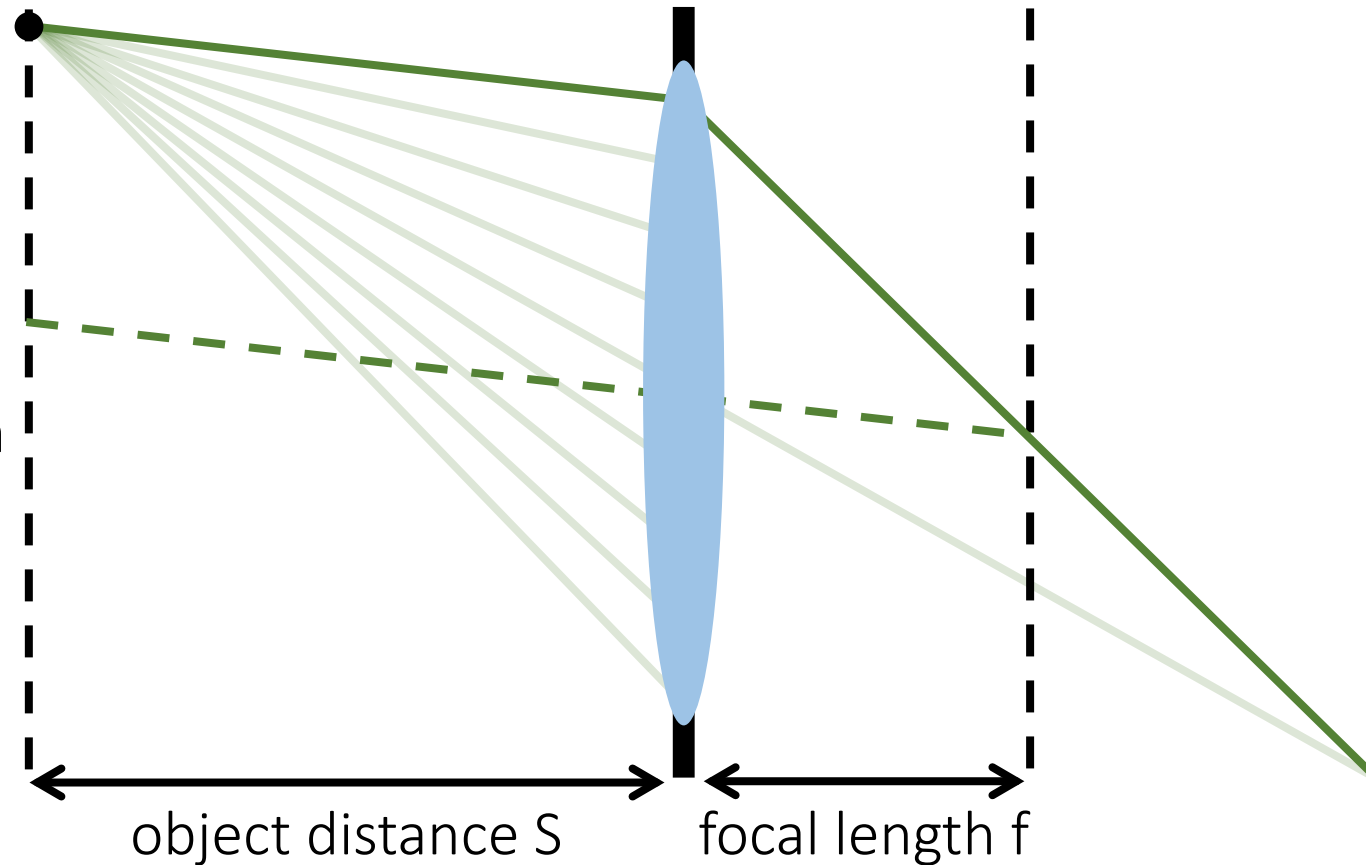

Tracing rays through a thin lens

Consider an object emitting a bundle of rays. How do they propagate through the lens?

1. Trace rays through lens center.
2. For all other rays:
 - a. Trace their parallel through lens center.
 - b. Connect on focal plane.

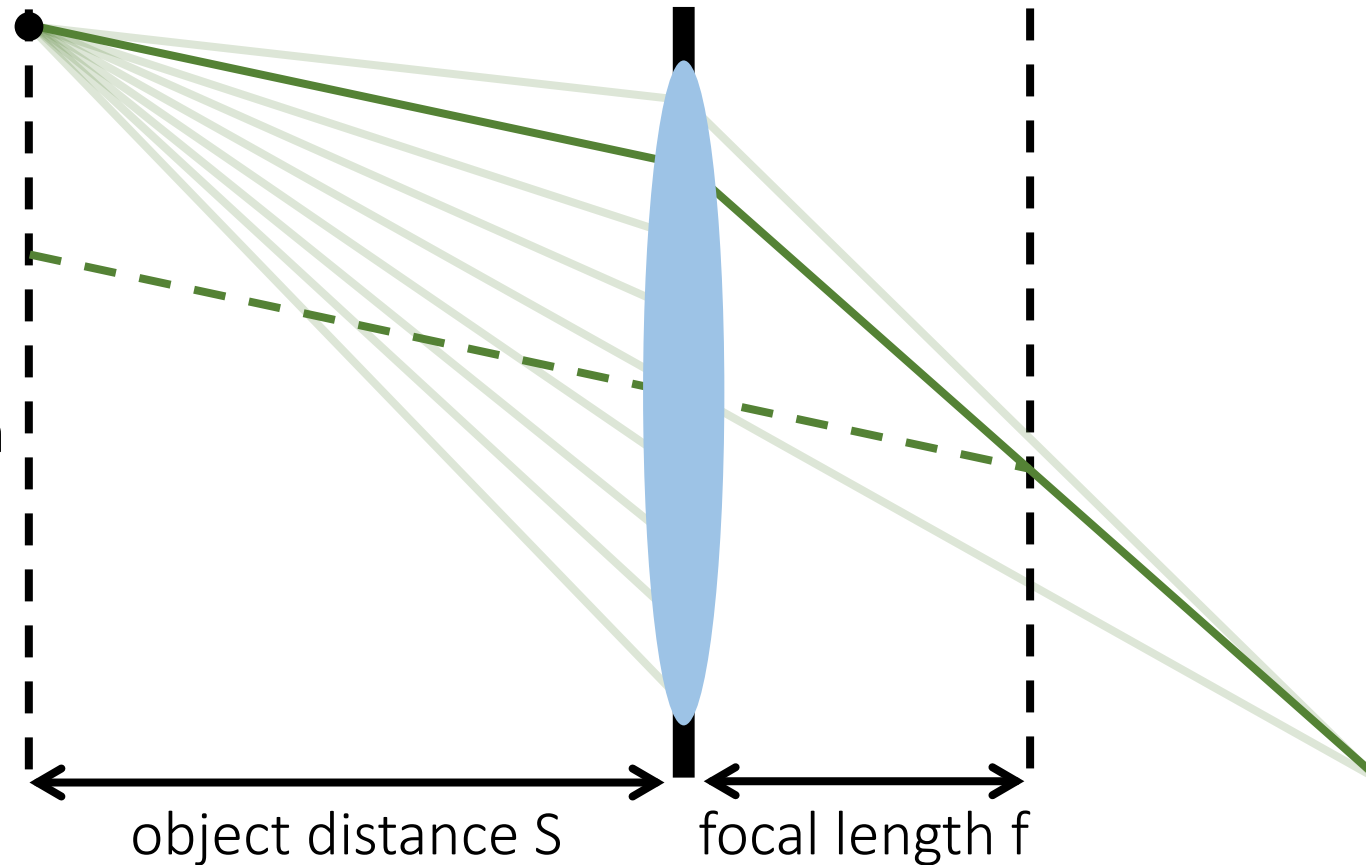

Tracing rays through a thin lens

Consider an object emitting a bundle of rays. How do they propagate through the lens?

1. Trace rays through lens center.
2. For all other rays:
 - a. Trace their parallel through lens center.
 - b. Connect on focal plane.

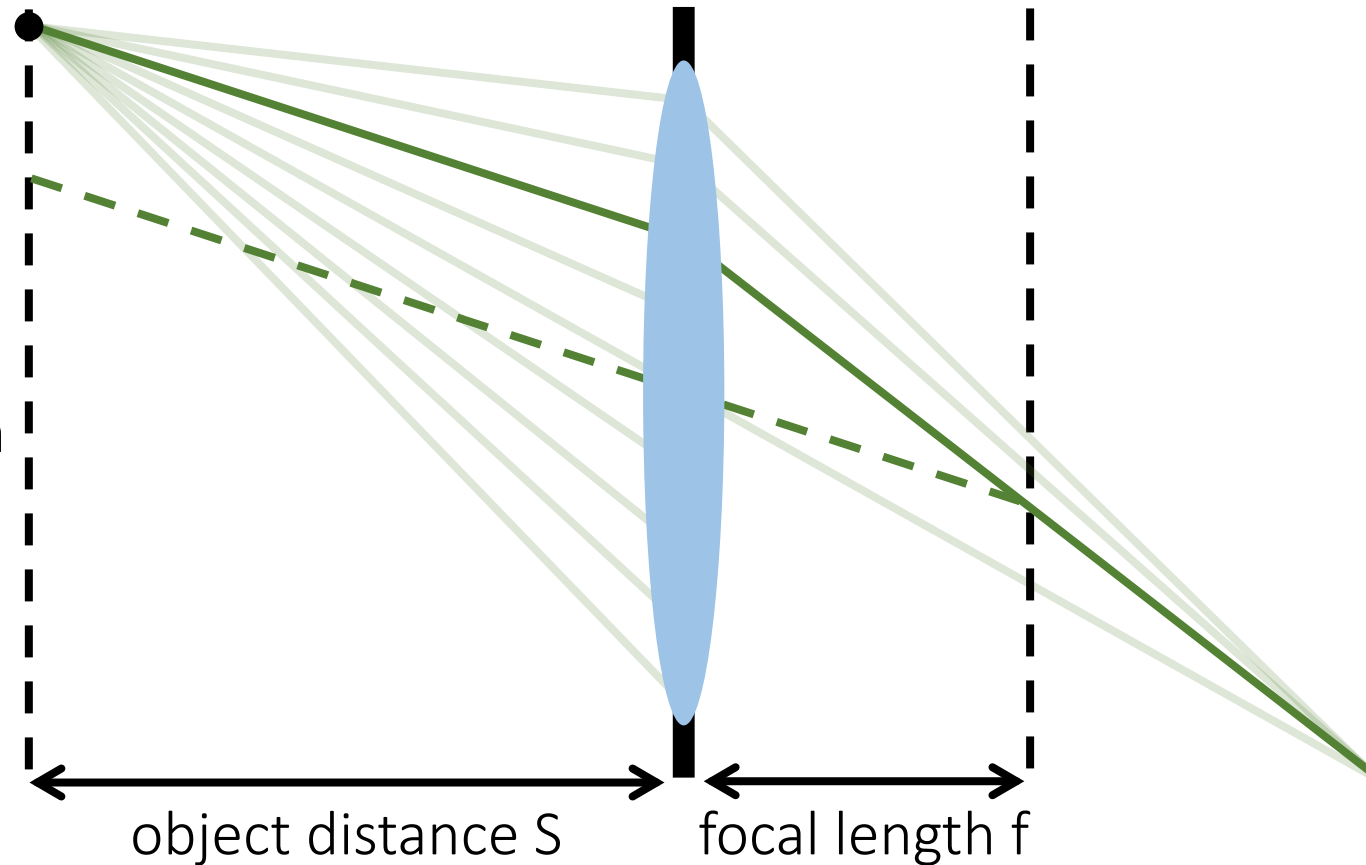

Tracing rays through a thin lens

Consider an object emitting a bundle of rays. How do they propagate through the lens?

1. Trace rays through lens center.
2. For all other rays:
 - a. Trace their parallel through lens center.
 - b. Connect on focal plane.

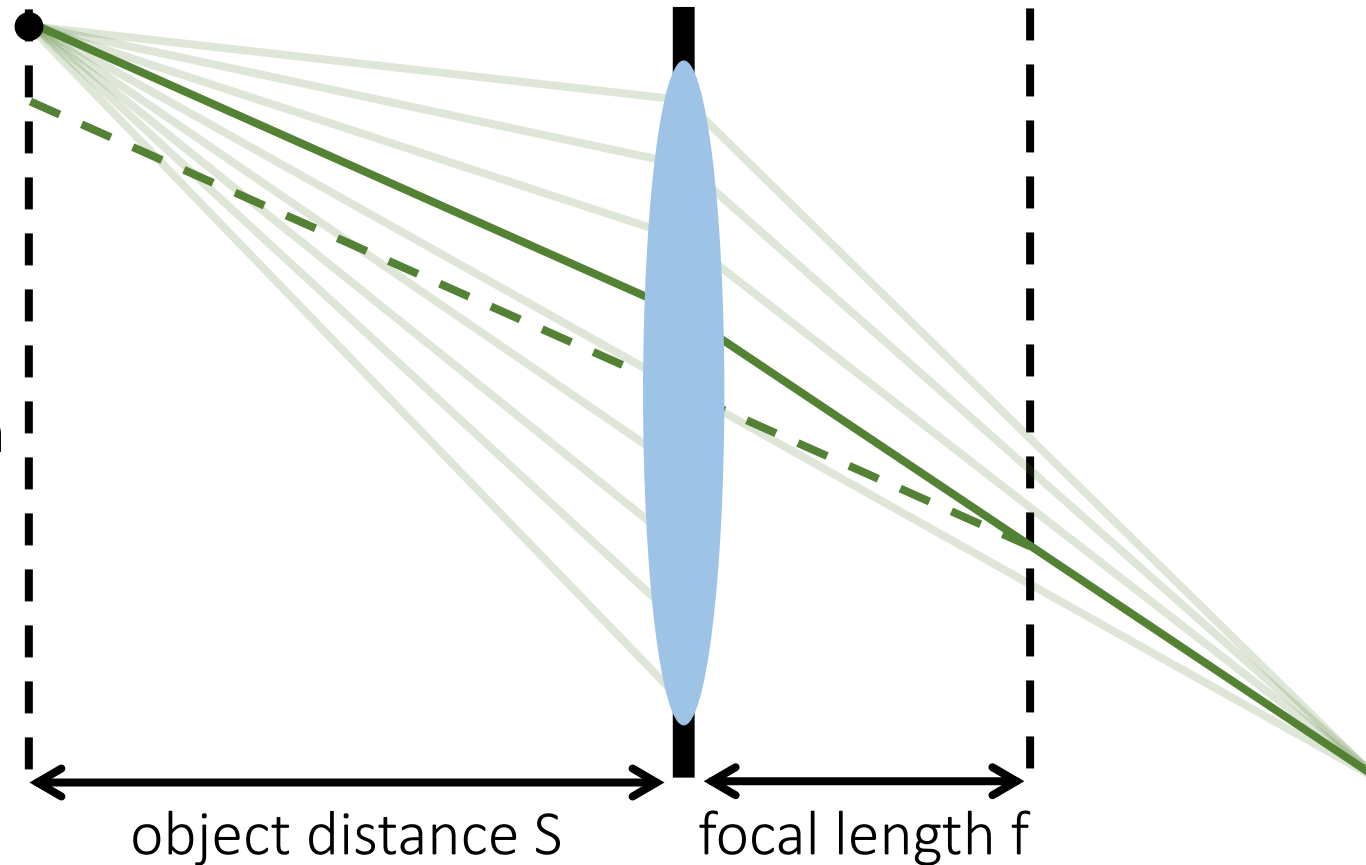

Tracing rays through a thin lens

Consider an object emitting a bundle of rays. How do they propagate through the lens?

1. Trace rays through lens center.
2. For all other rays:
 - a. Trace their parallel through lens center.
 - b. Connect on focal plane.

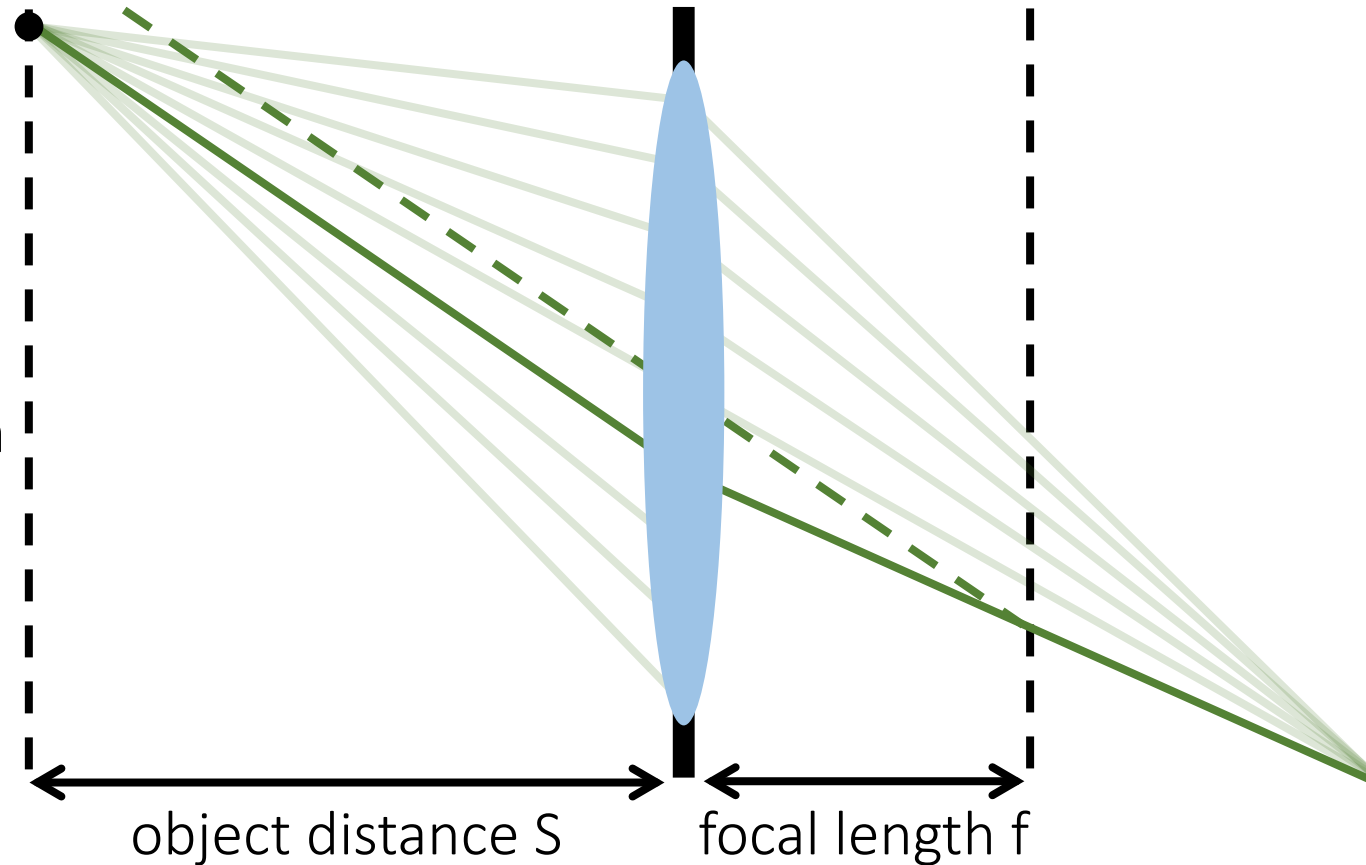

Tracing rays through a thin lens

Consider an object emitting a bundle of rays. How do they propagate through the lens?

1. Trace rays through lens center.
2. For all other rays:
 - a. Trace their parallel through lens center.
 - b. Connect on focal plane.

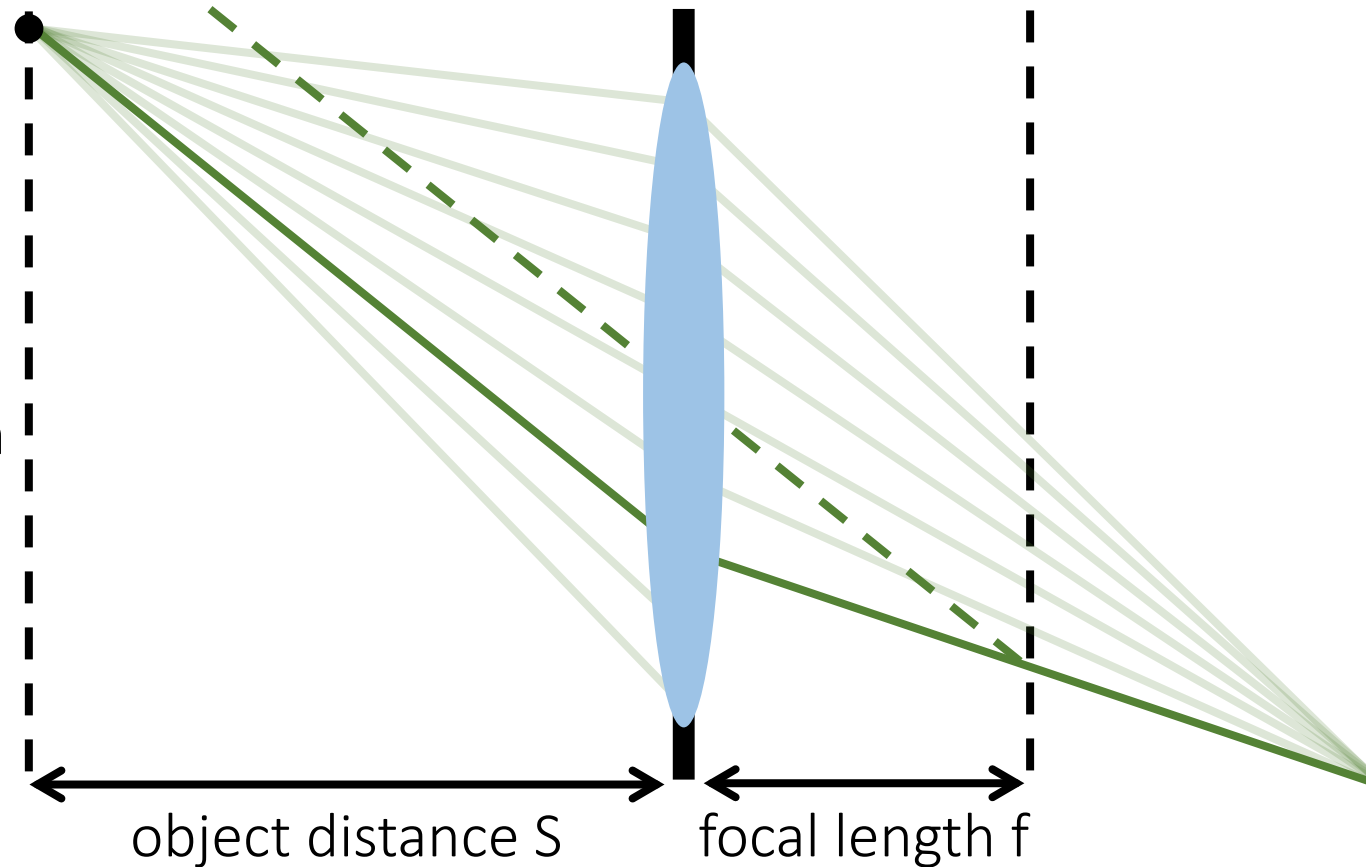

Tracing rays through a thin lens

Consider an object emitting a bundle of rays. How do they propagate through the lens?

1. Trace rays through lens center.
2. For all other rays:
 - a. Trace their parallel through lens center.
 - b. Connect on focal plane.

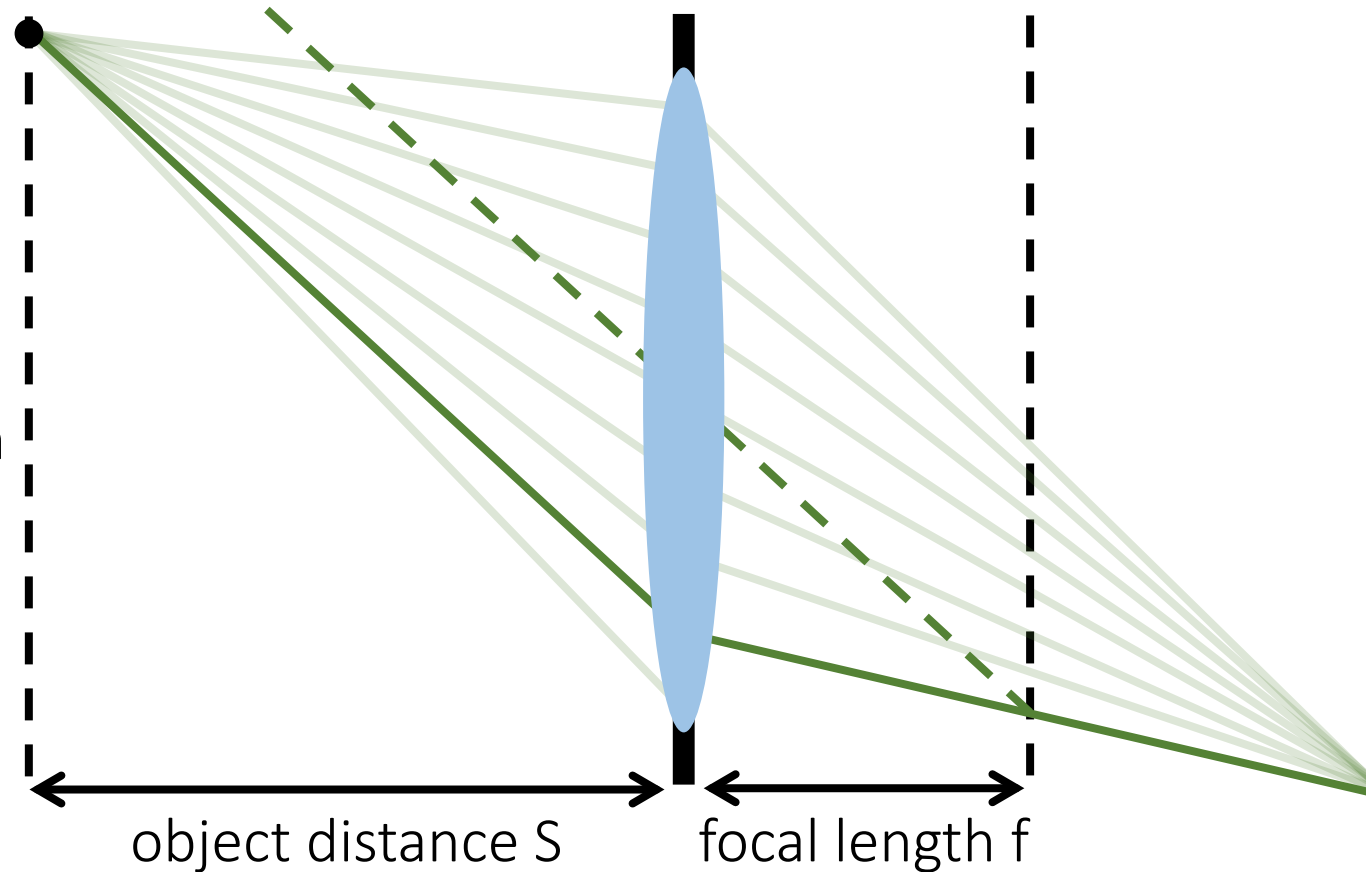

Tracing rays through a thin lens

Consider an object emitting a bundle of rays. How do they propagate through the lens?

1. Trace rays through lens center.
2. For all other rays:
 - a. Trace their parallel through lens center.
 - b. Connect on focal plane.

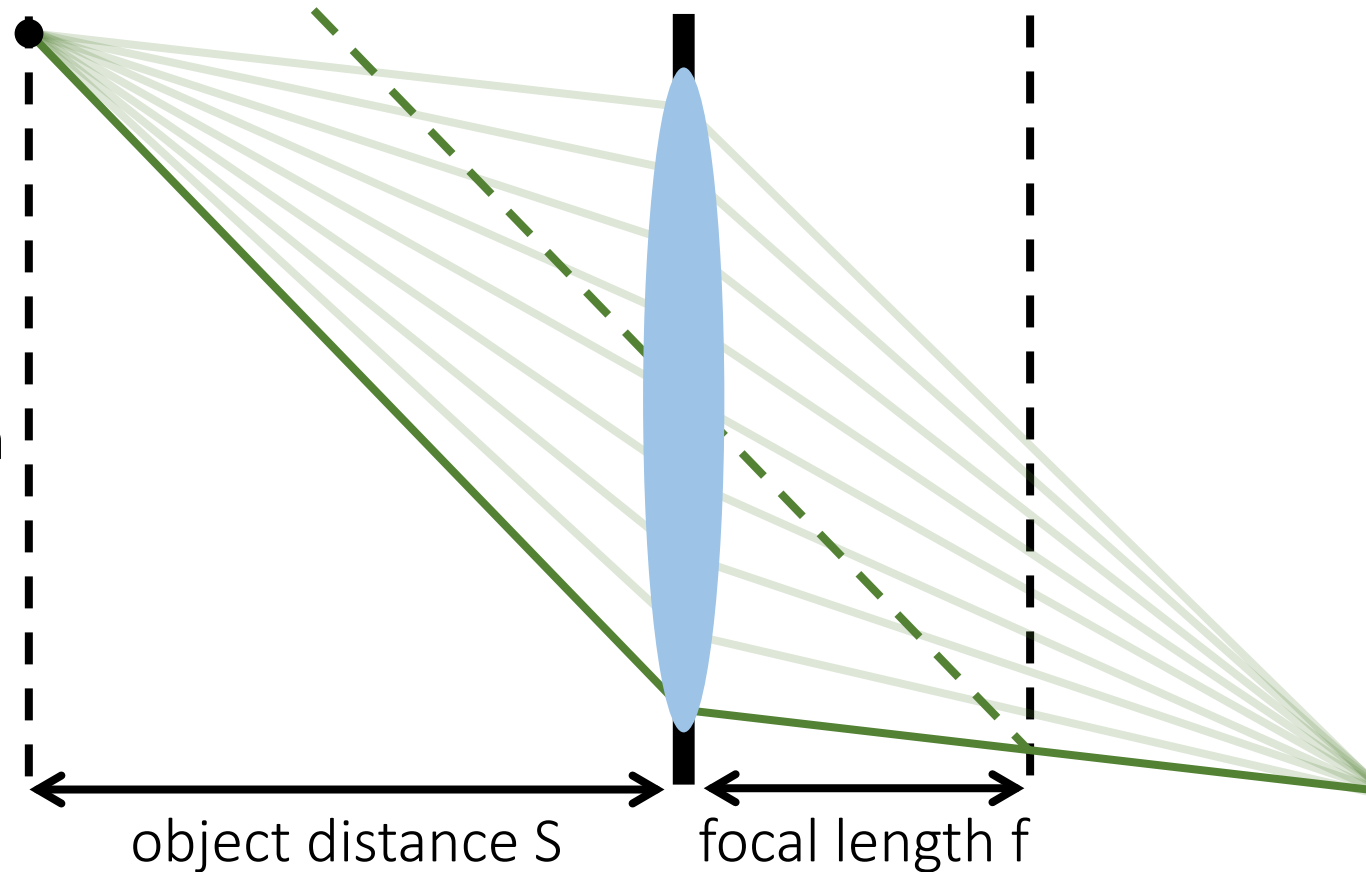

Tracing rays through a thin lens

Consider an object emitting a bundle of rays. How do they propagate through the lens?

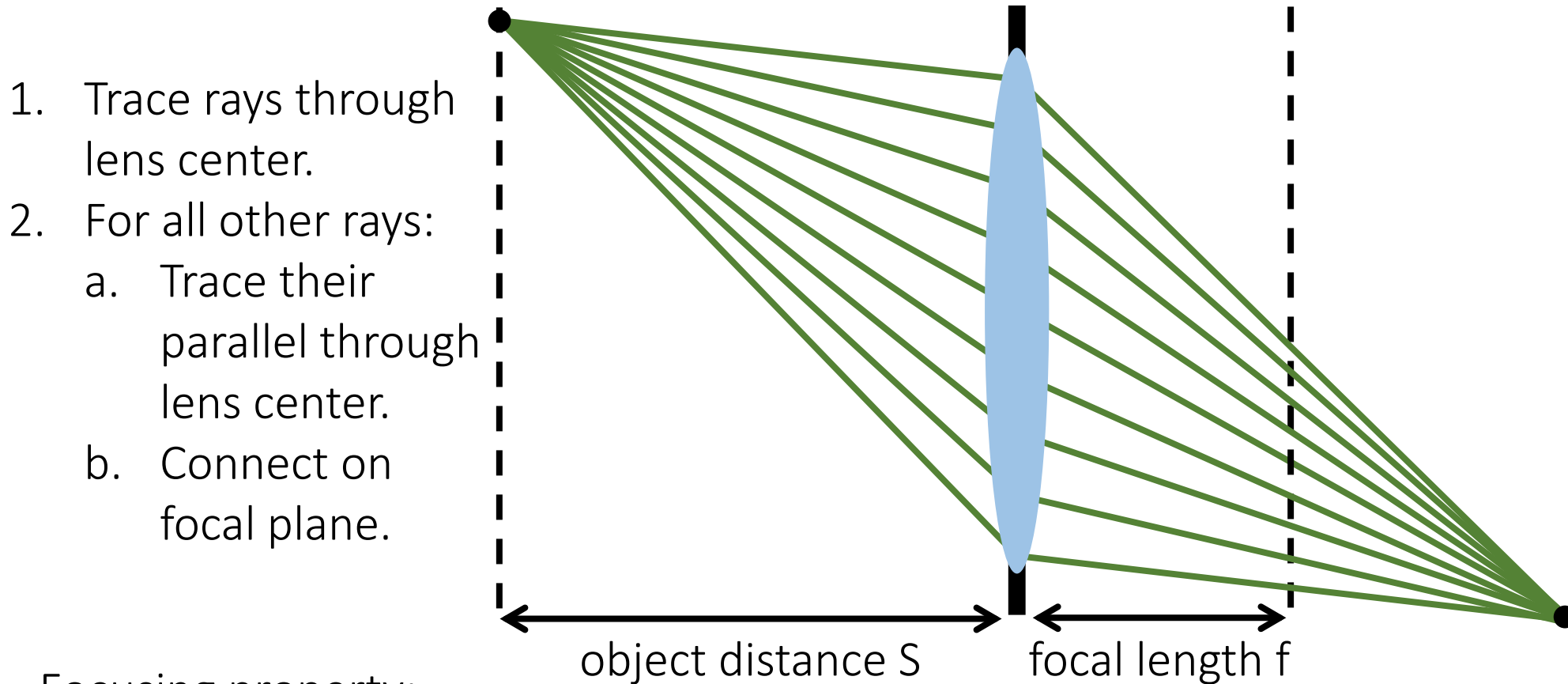

Focusing property:

1. Rays emitted from a point on one side converge to a point on the other side.

Tracing rays through a thin lens

Consider an object emitting a bundle of rays. How do they propagate through the lens?

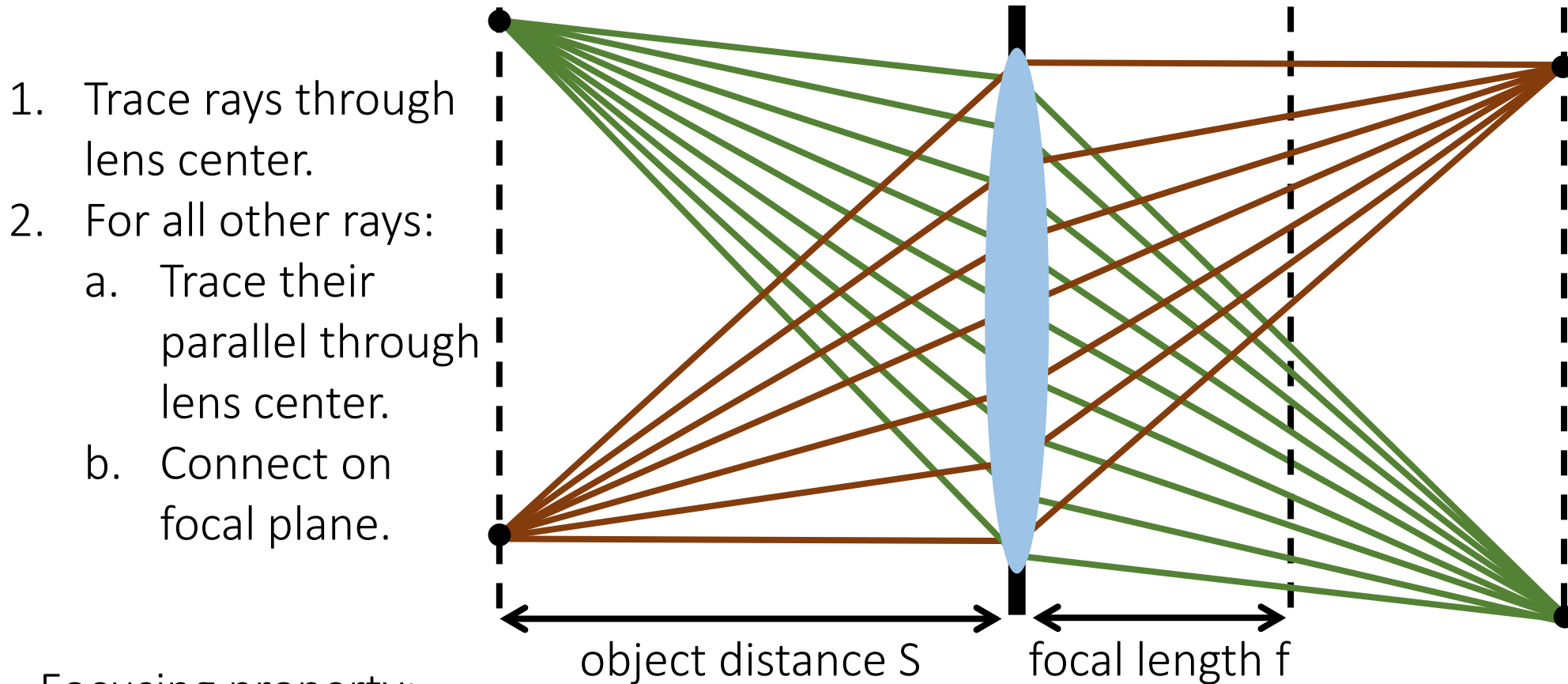

1. Trace rays through lens center.
2. For all other rays:
 - a. Trace their parallel through lens center.
 - b. Connect on focal plane.

Focusing property:

1. Rays emitted from a point on one side converge to a point on the other side.
2. Bundles emitted from a plane parallel to the lens converge on a common plane.

Gaussian lens formula

How can we relate scene-space (S, y) and image space (S', y') quantities?

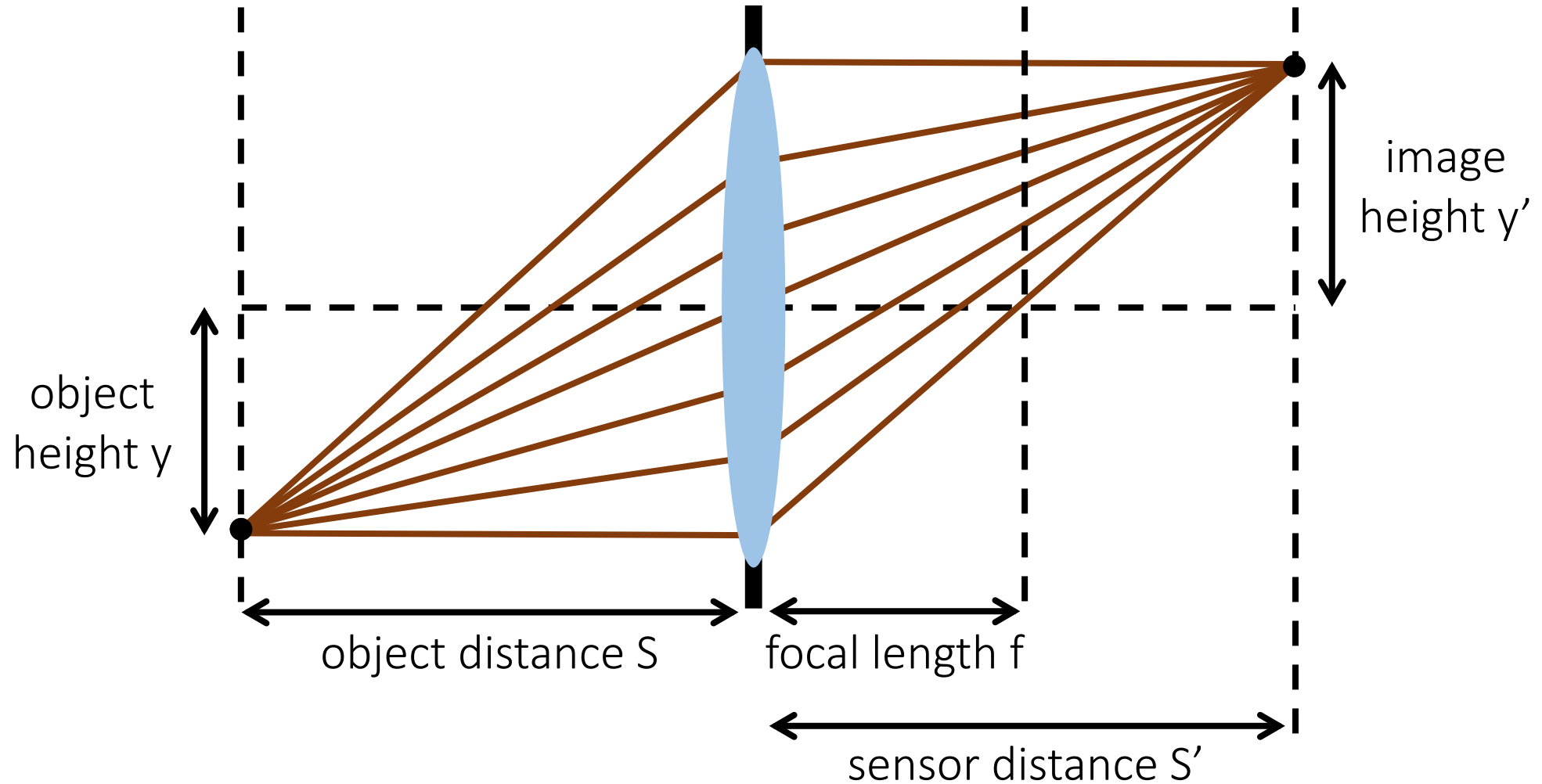

Gaussian lens formula

How can we relate scene-space (S, y) and image space (S', y') quantities?

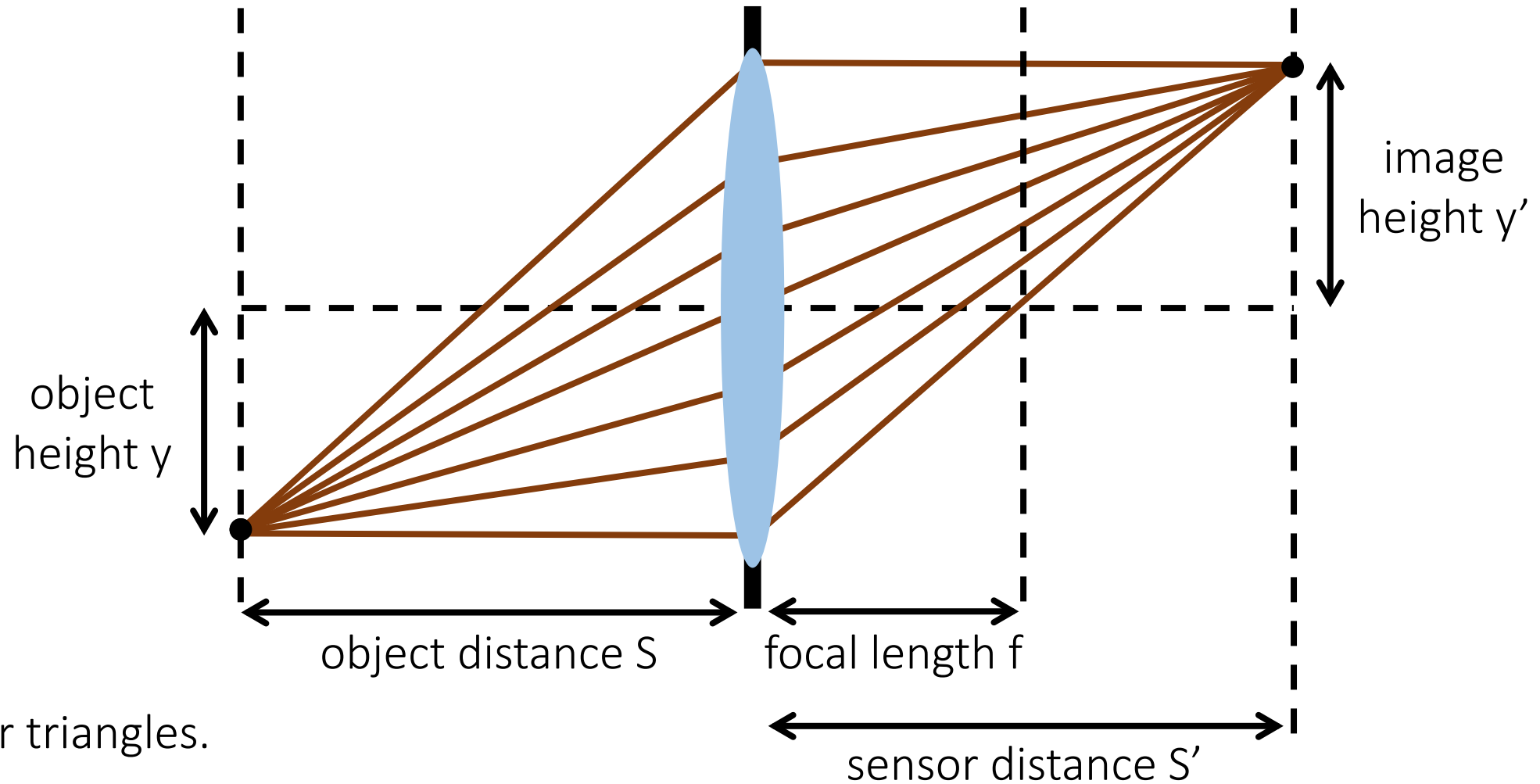

Use similar triangles.

Gaussian lens formula

How can we relate scene-space (S, y) and image space (S', y') quantities?

$$\frac{y'}{y} = ?$$

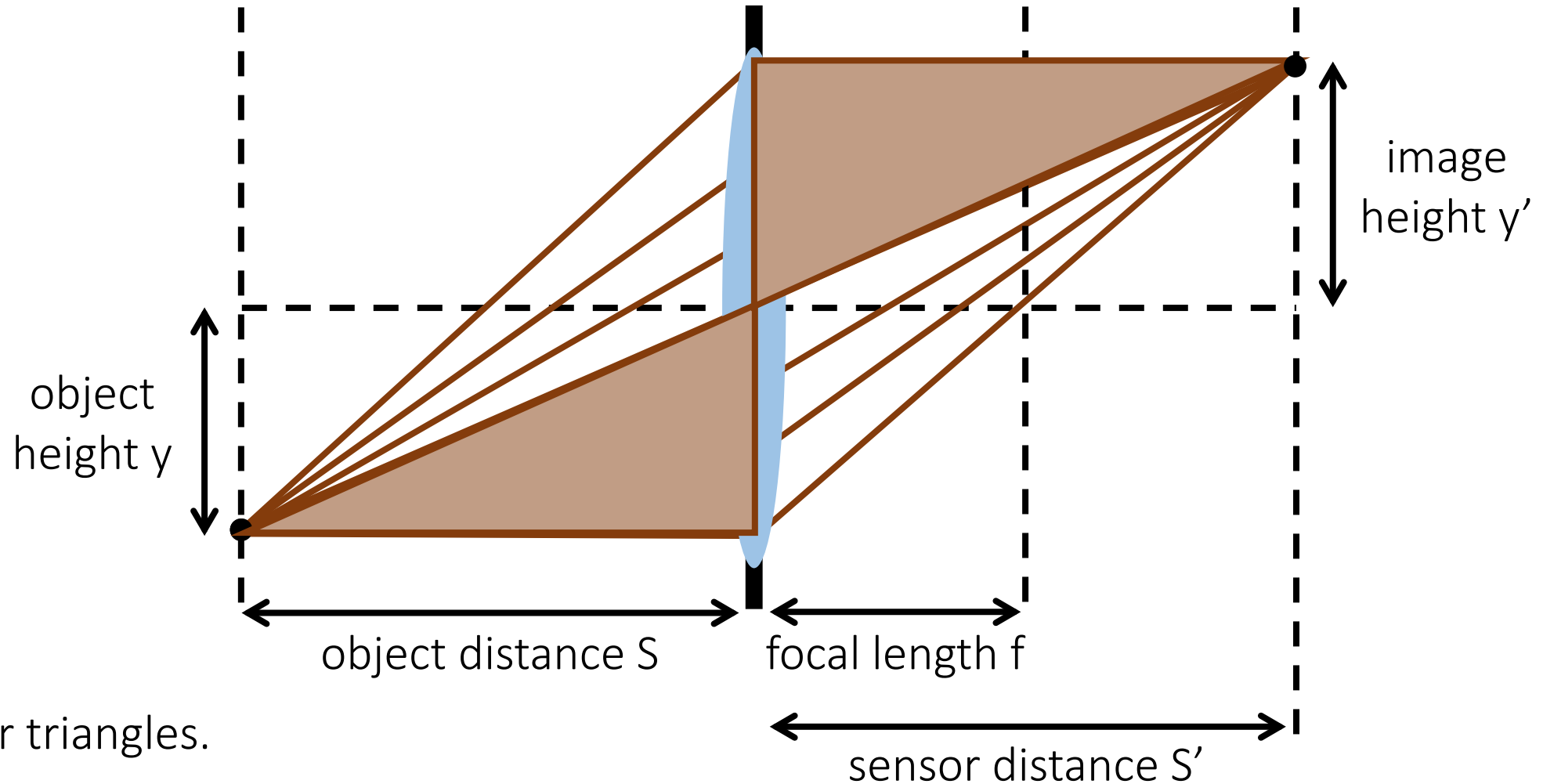

Use similar triangles.

Gaussian lens formula

How can we relate scene-space (S, y) and image space (S', y') quantities?

$$\frac{y'}{y} = \frac{S'}{S}$$

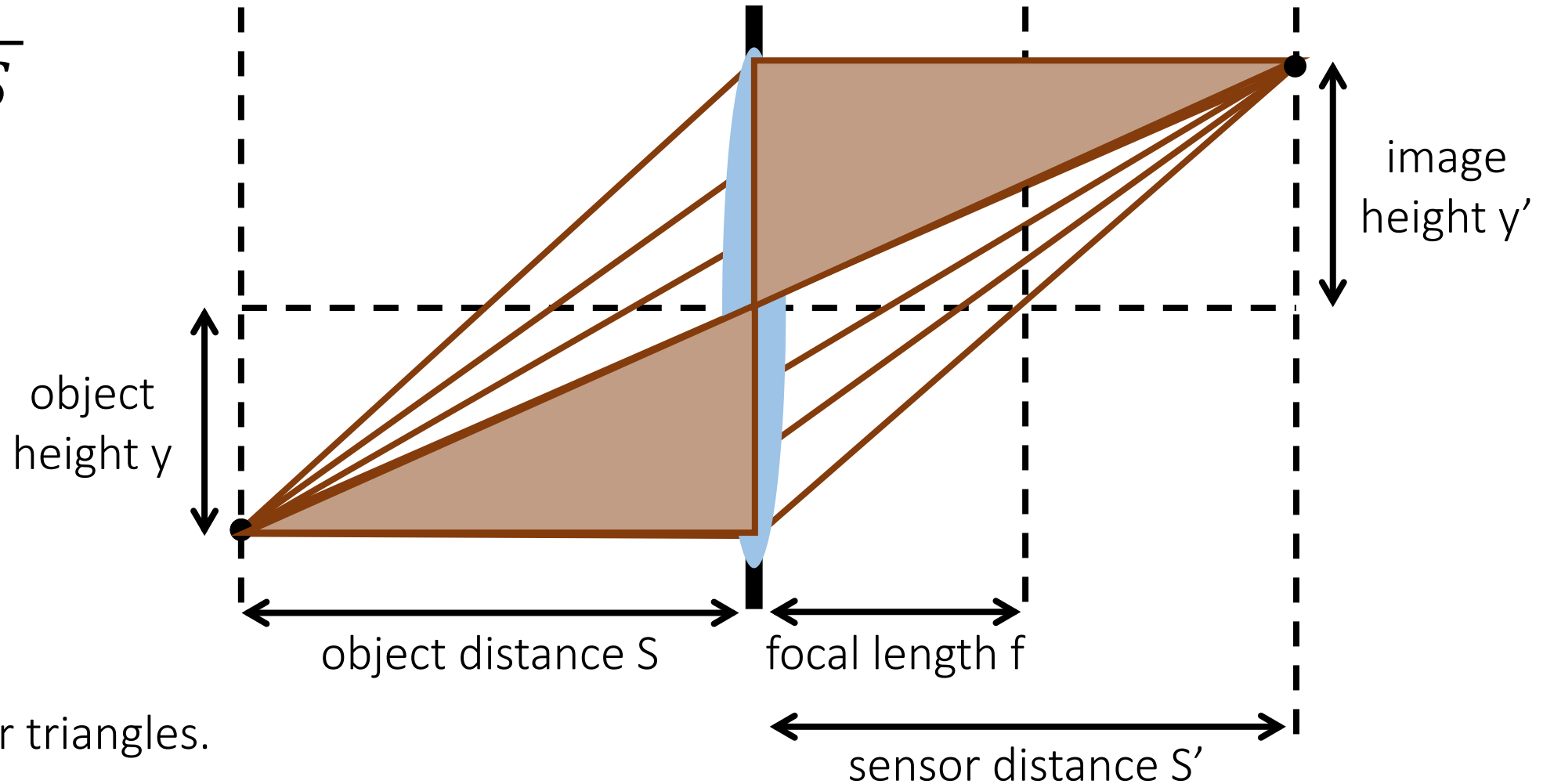

Use similar triangles.

Gaussian lens formula

How can we relate scene-space (S, y) and image space (S', y') quantities?

$$\frac{y'}{y} = \frac{S'}{S}$$

$$\frac{y'}{y} = ?$$

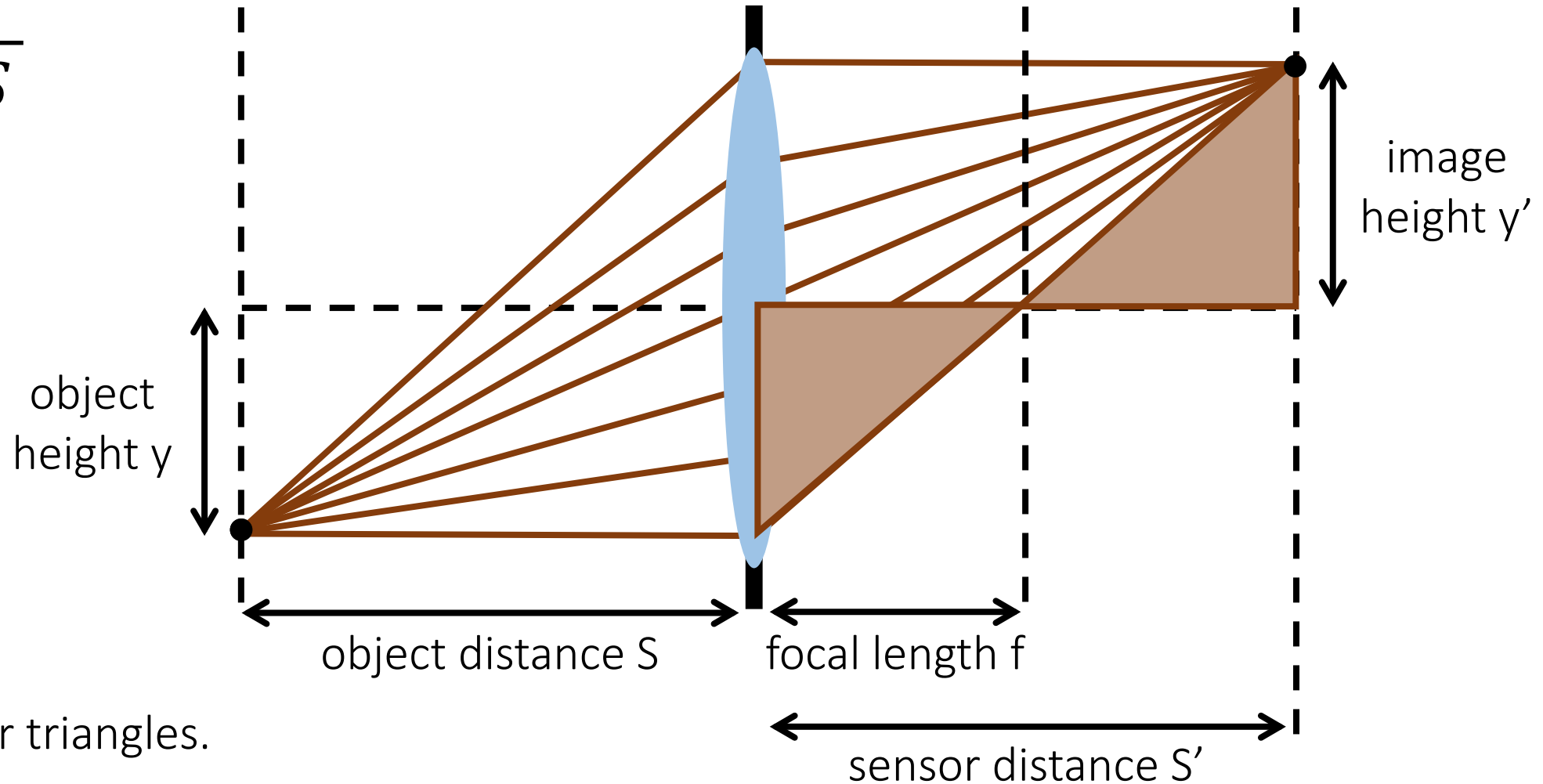

Use similar triangles.

Gaussian lens formula

How can we relate scene-space (S, y) and image space (S', y') quantities?

$$\frac{y'}{y} = \frac{S'}{S}$$

$$\frac{y'}{y} = \frac{S' - f}{f}$$

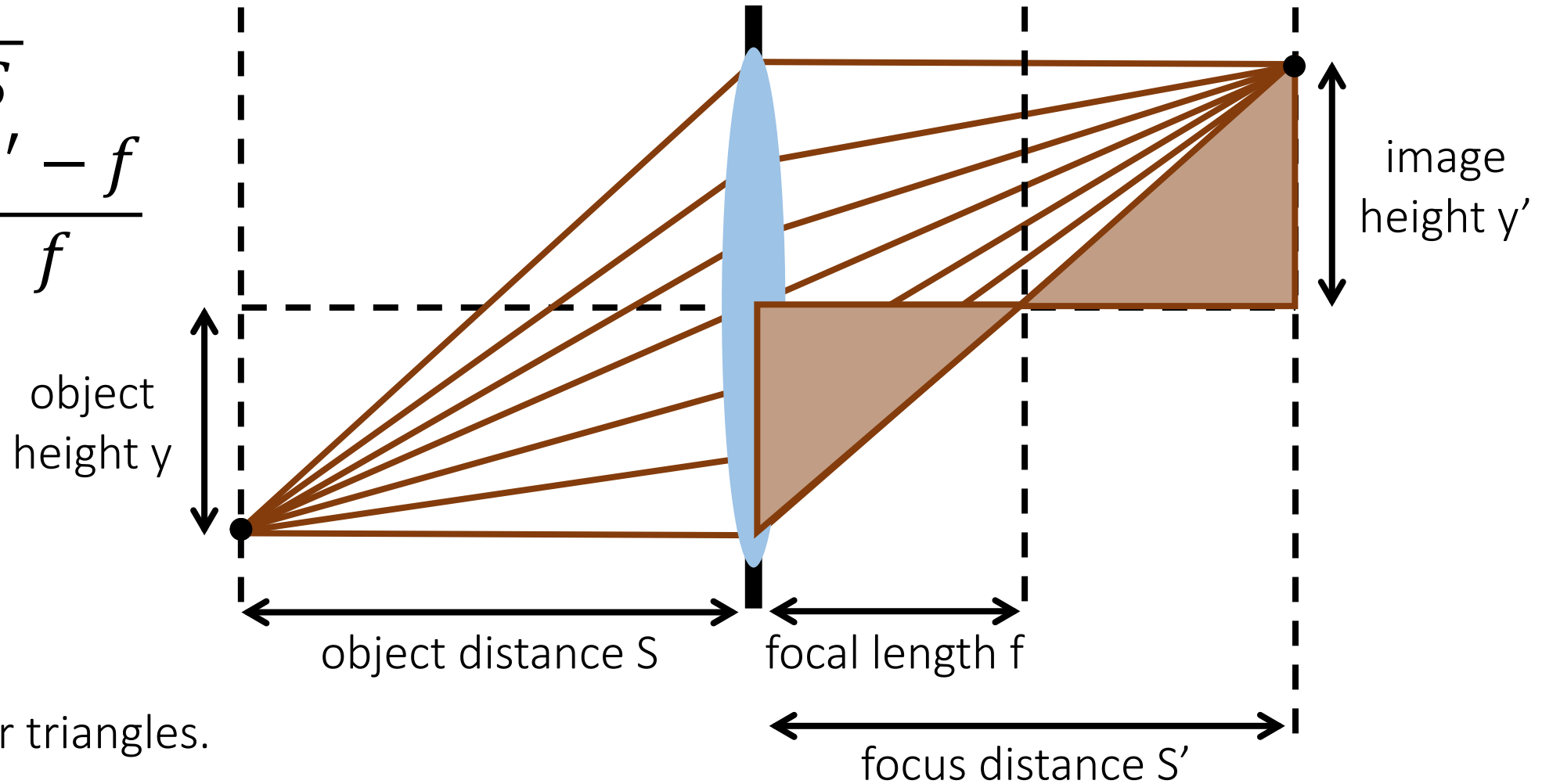

Use similar triangles.

Gaussian lens formula

How can we relate scene-space (S, y) and image space (S', y') quantities?

$$\frac{1}{S'} + \frac{1}{S} = \frac{1}{f}$$

$$m = \frac{S' - f}{f}$$

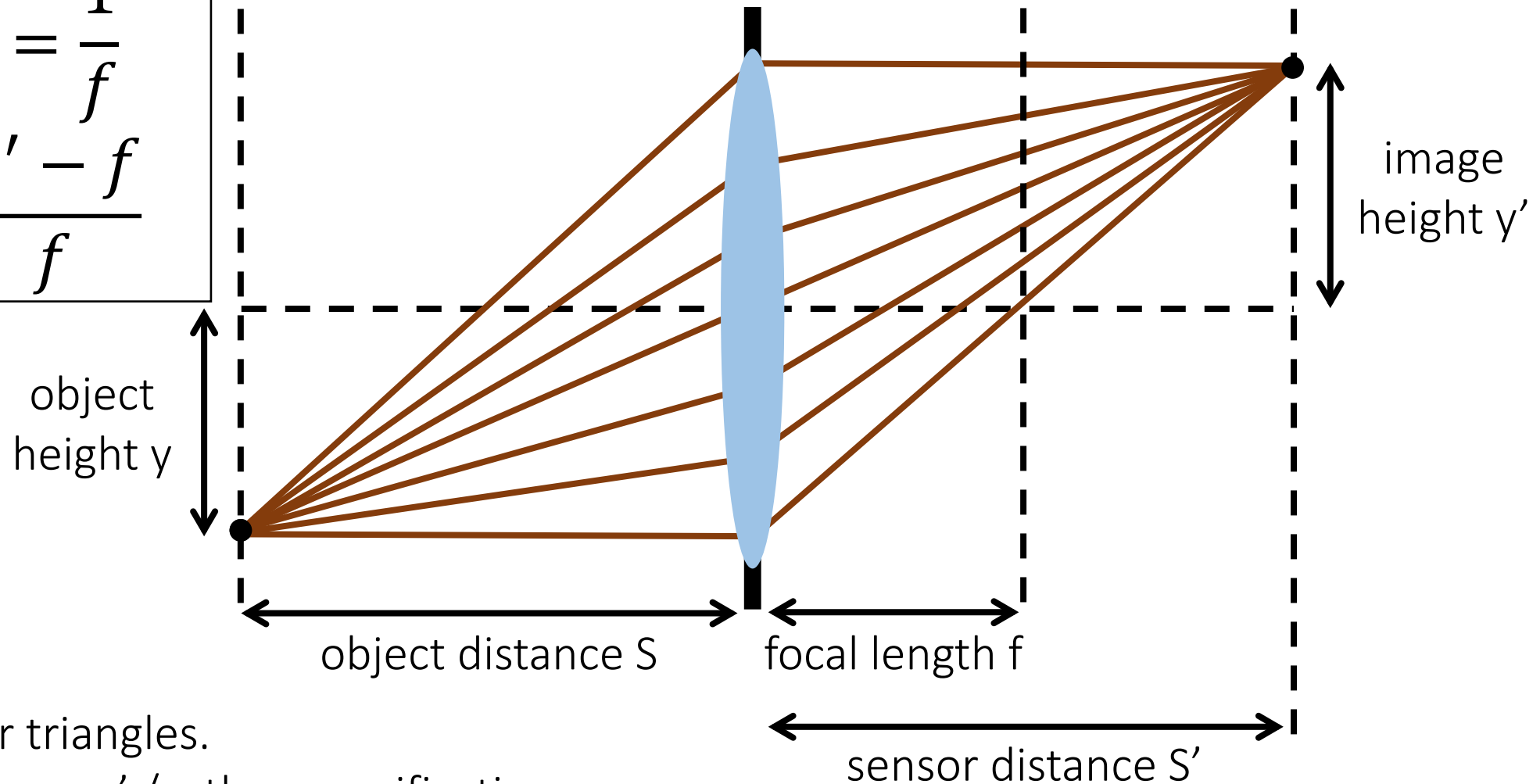

Use similar triangles.

- We call $m = y' / y$ the magnification.

Special focus distances

$$S' = f, S = ?, m = ?$$

$$\frac{1}{S'} + \frac{1}{S} = \frac{1}{f}$$

$$m = \frac{S' - f}{f}$$

Special focus distances

$S' = f, S = \infty, m = 0 \rightarrow$ infinity focus (parallel rays)

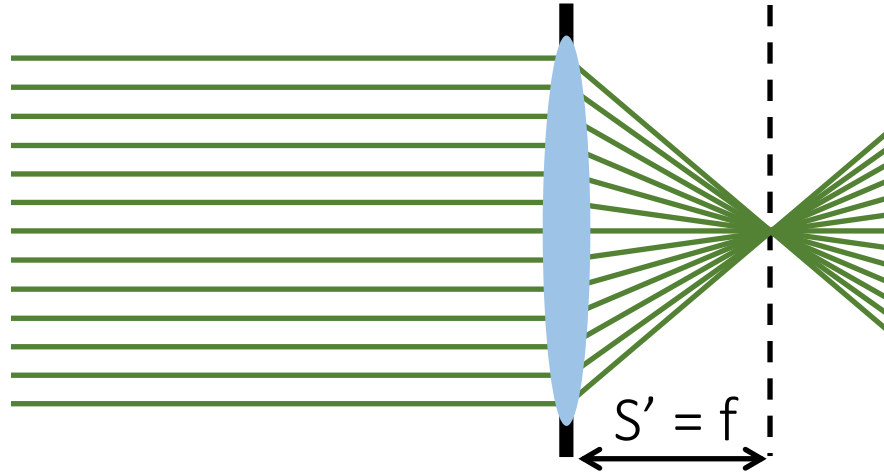

$S' = S = ?, m = ?$

$$\frac{1}{S'} + \frac{1}{S} = \frac{1}{f}$$

$$m = \frac{S' - f}{f}$$

Special focus distances

$S' = f, S = \infty, m = 0 \rightarrow$ infinity focus (parallel rays)

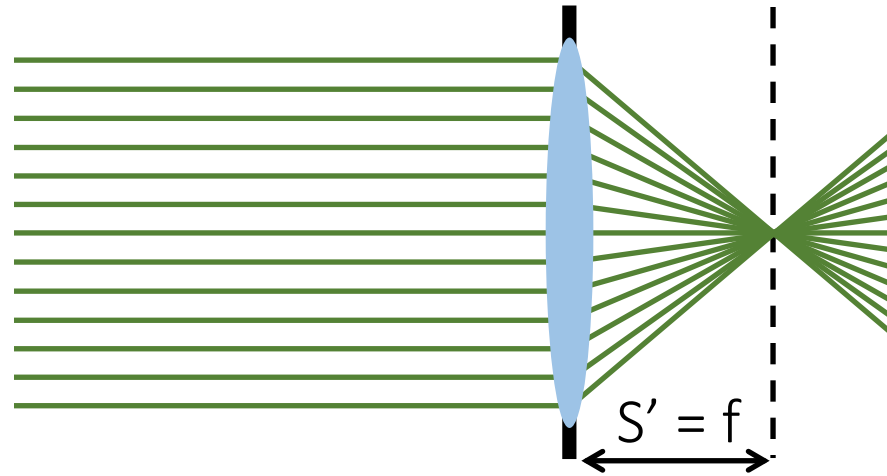

$$\frac{1}{S'} + \frac{1}{S} = \frac{1}{f}$$

$$m = \frac{S' - f}{f}$$

$S' = S = 2f, m = 1 \rightarrow$ object is reproduced in real-life size

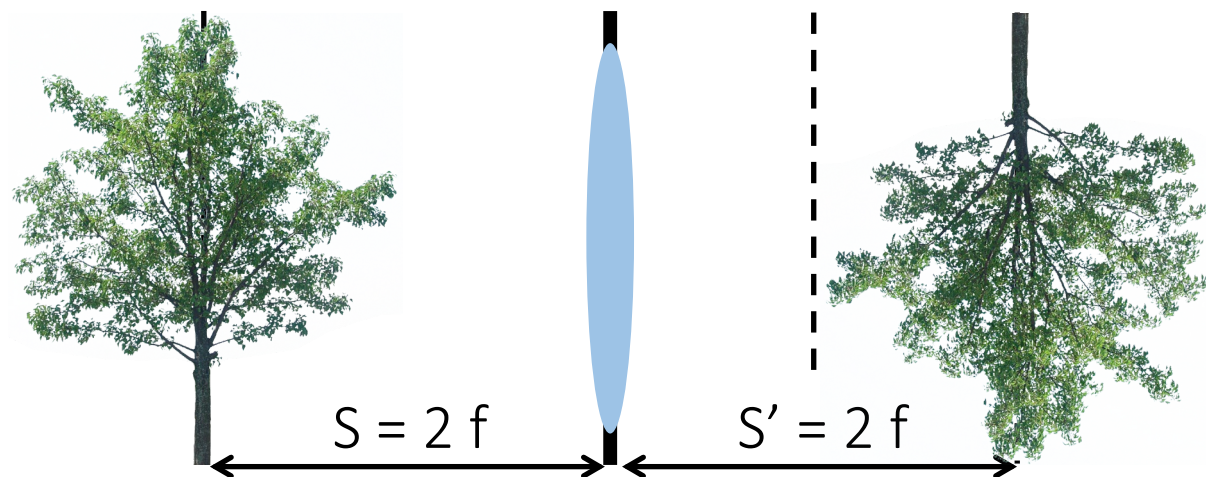

Free lunch?

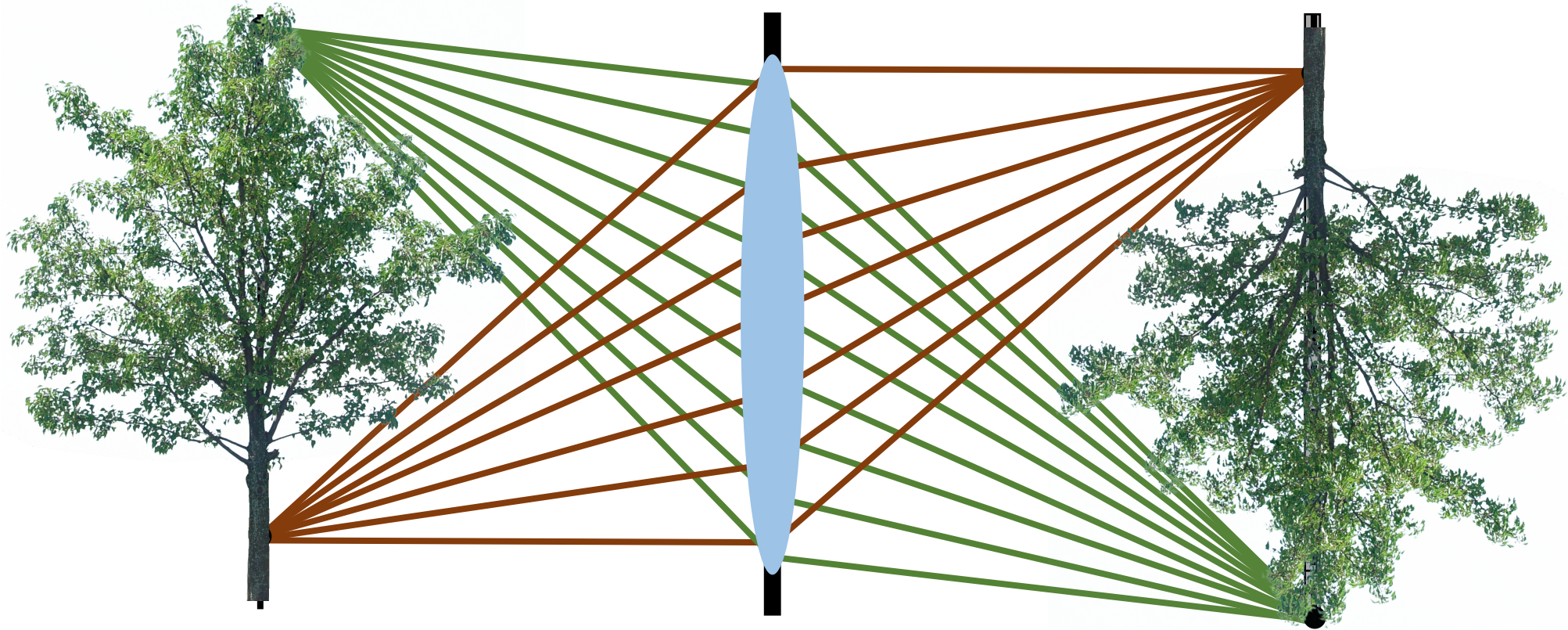

By using a lens, we simultaneously achieve:

1. Image is sharp.
2. Signal-to-noise ratio is high.

Do we lose anything by using a lens?

Defocus

What happens if we don't place the sensor at the focus distance?

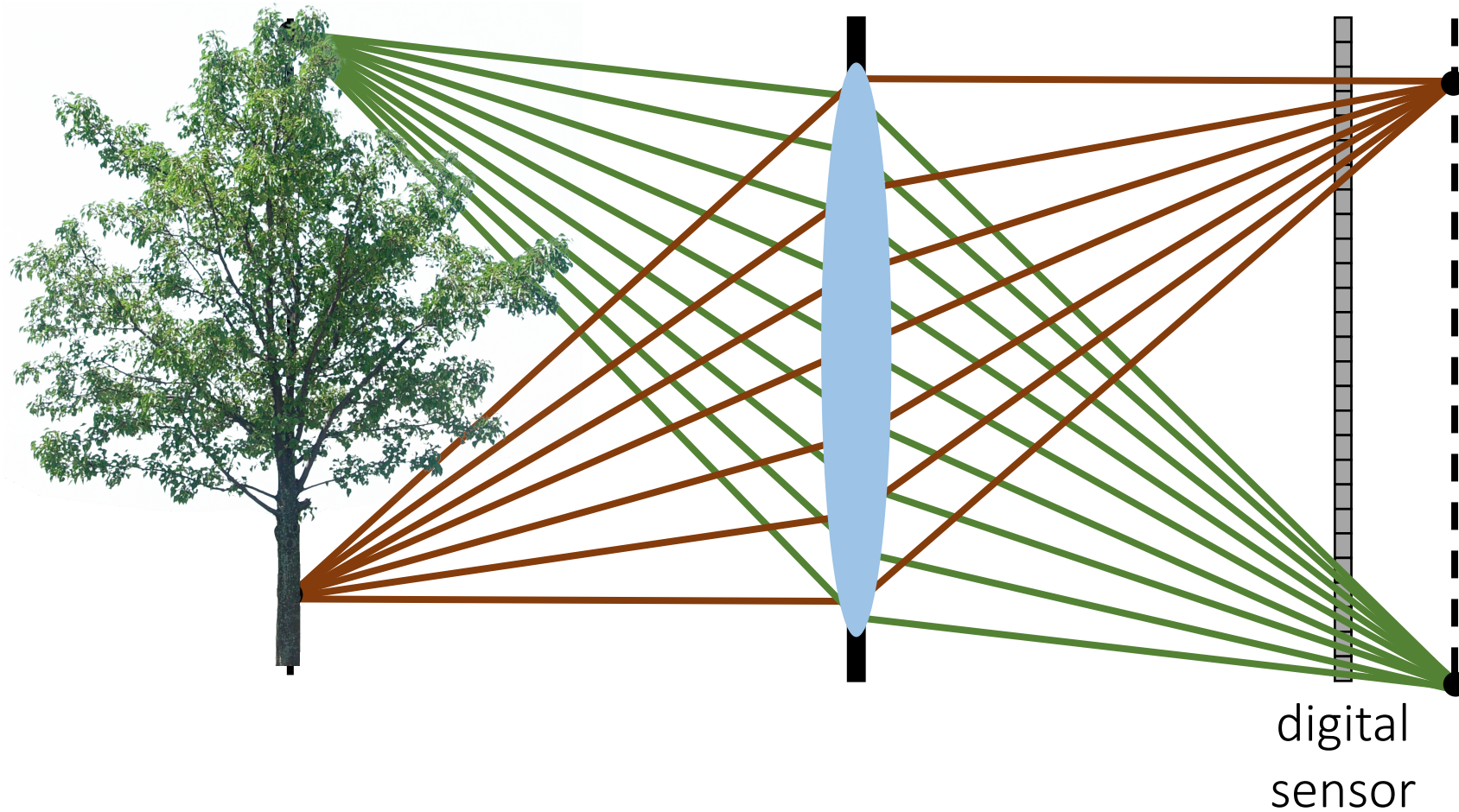

Defocus

What happens if we don't place the sensor at the focus distance?

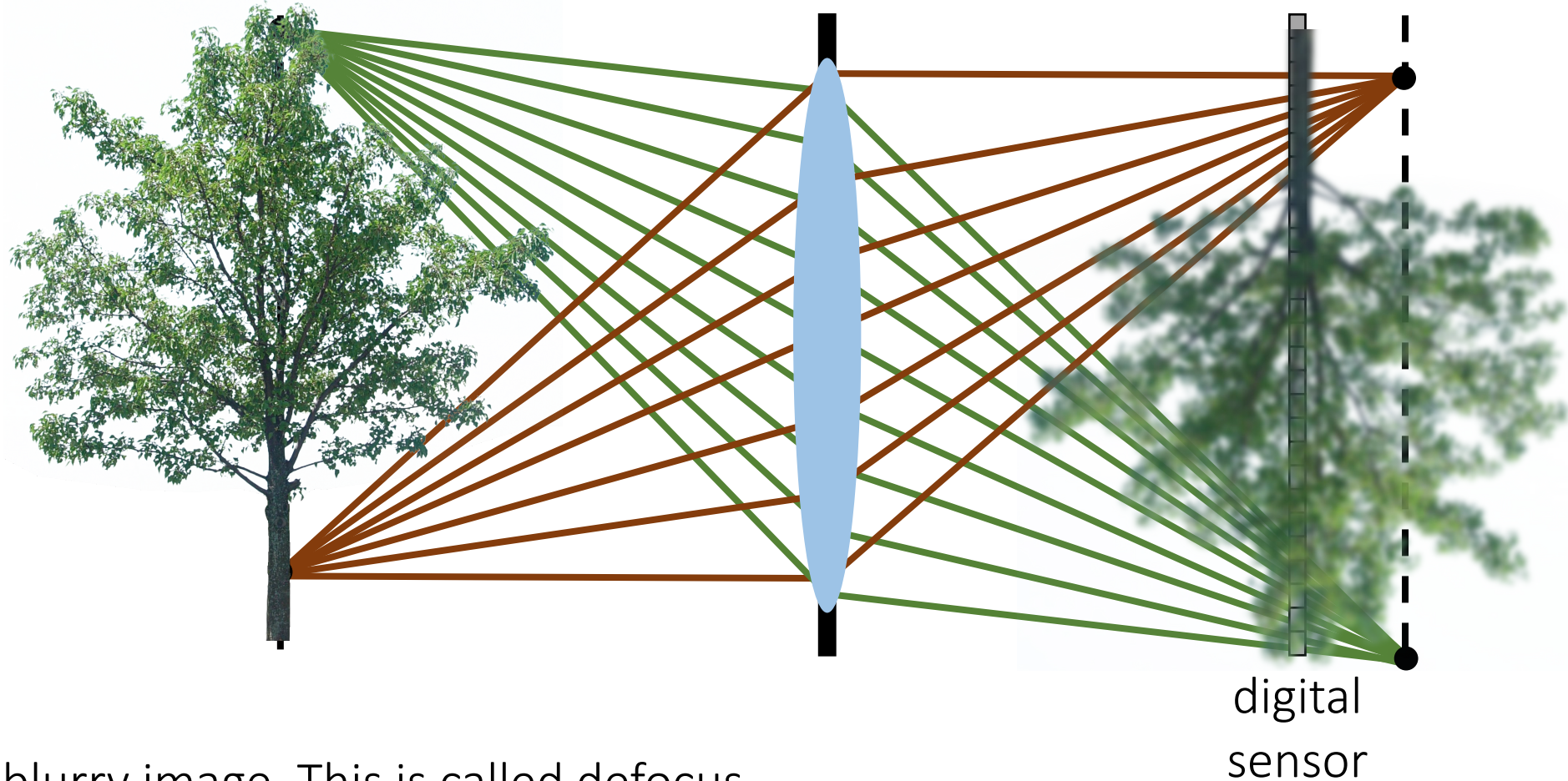

We get a blurry image. This is called defocus.

- Defocus never happens with an ideal pinhole camera.

Defocus

Can't we just move the sensor to the correct distance?

Defocus

Can't we just move the sensor to the correct distance?

where we need to move sensor
for squirrel to be in focus

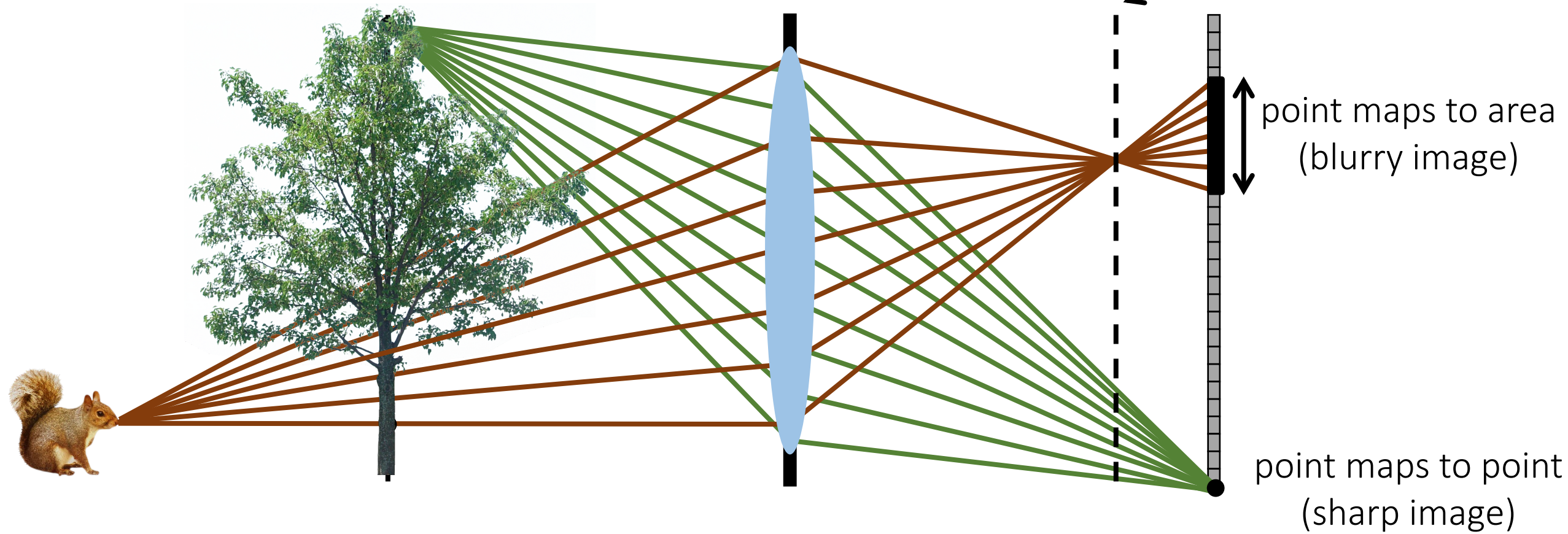

Unless our scene is just one plane, part of it will always be out of focus.

How do we control what is in focus?

How do we control what is in focus?

We change the distance between the sensor and the lens

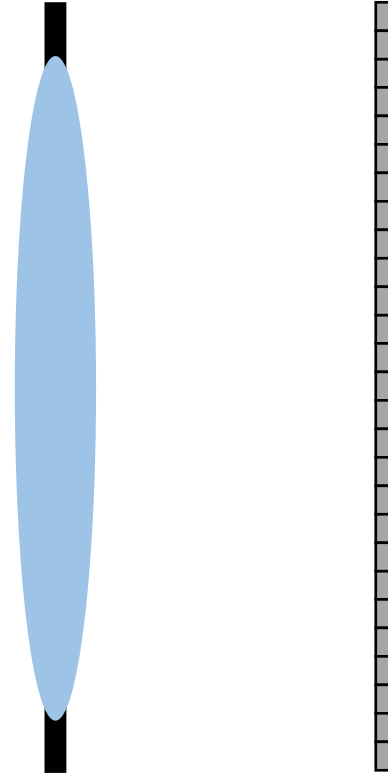

How do we control what is in focus?

We change the distance between the sensor and the lens

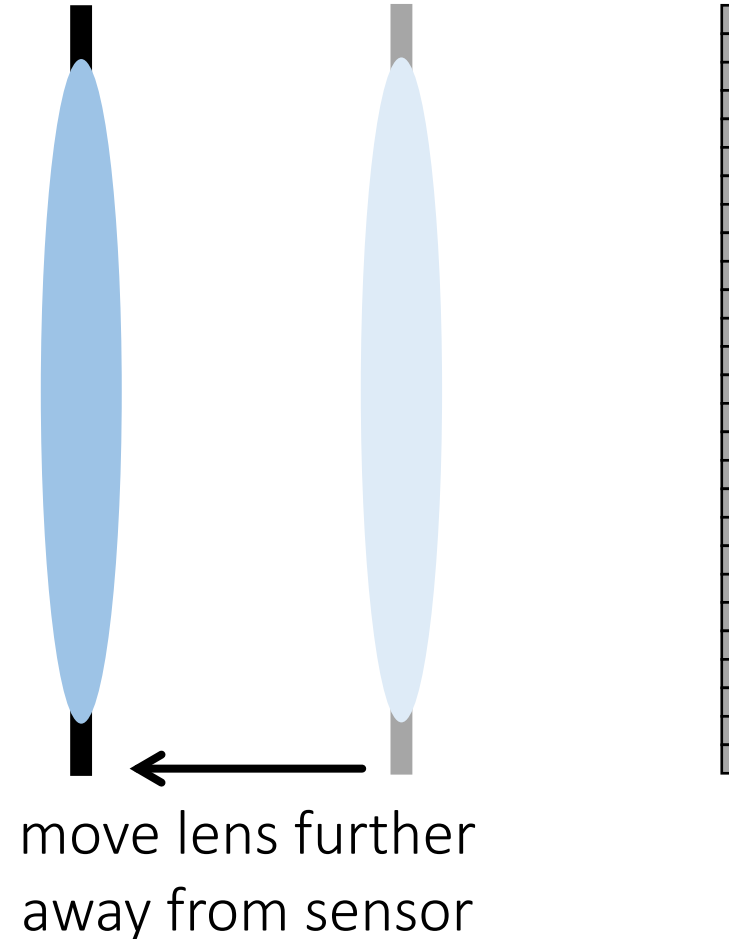

- What happens to plane in focus?

How do we control what is in focus?

We change the distance between the sensor and the lens

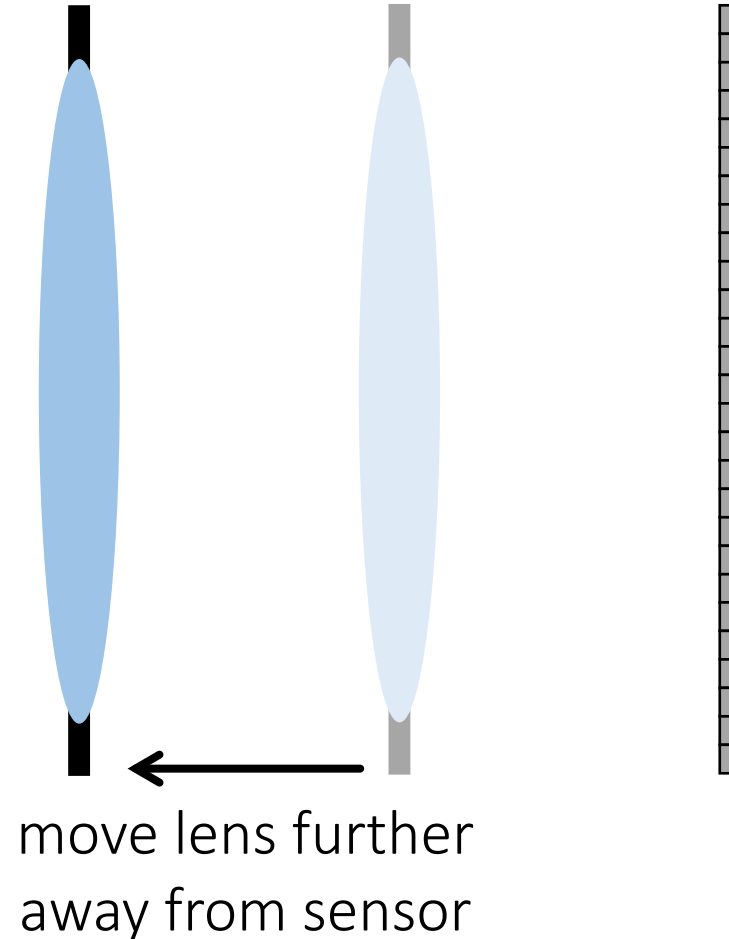
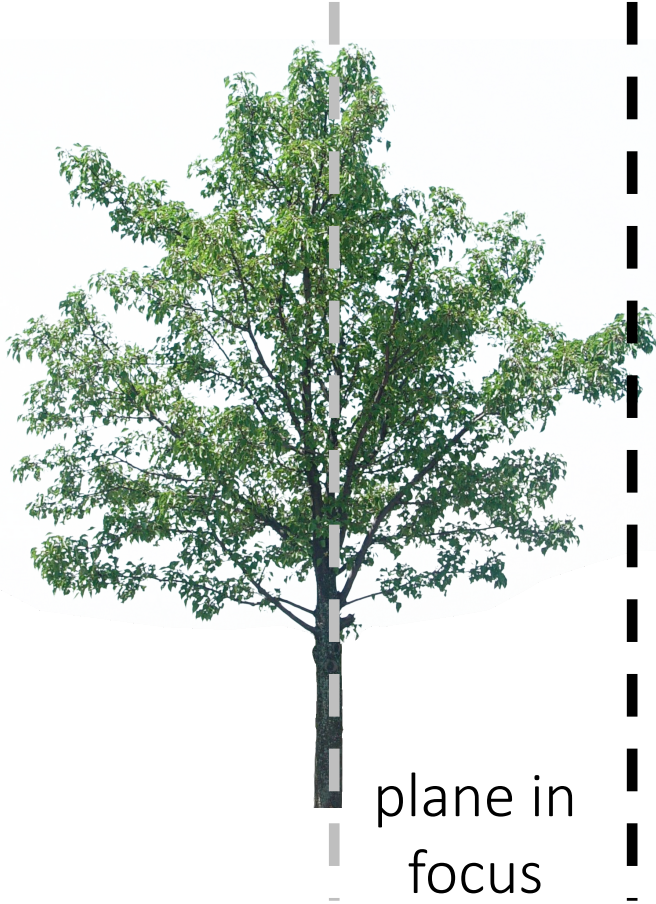

- What happens to plane in focus? → It moves closer.

The lens on your camera

Focus ring: controls distance of lens from sensor



Demonstration



Defocus

Does this mean that lenses are only good for planar scenes?

Circle of confusion

How do we find where the point will focus?

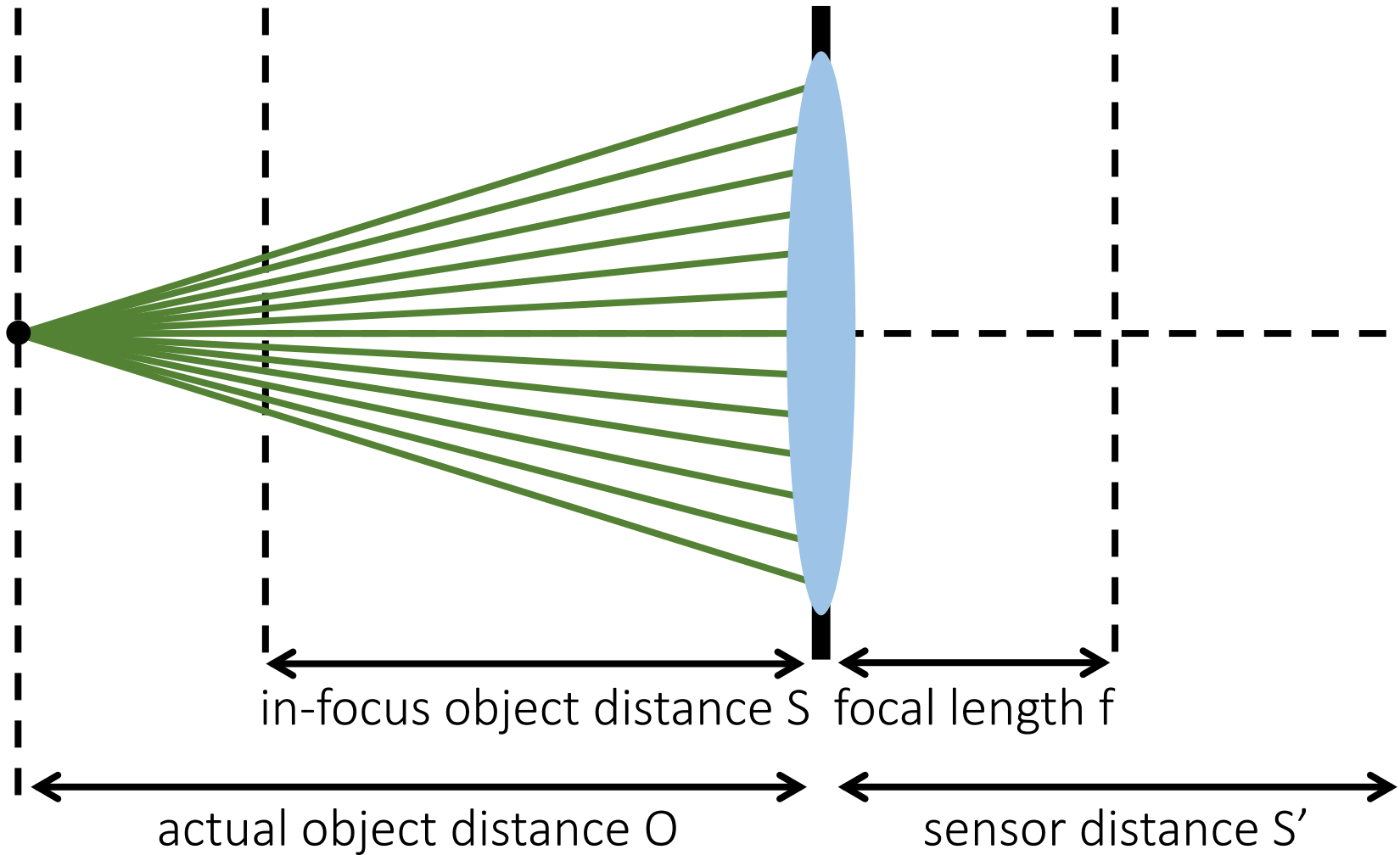

Circle of confusion

Will the point focus at a distance smaller or larger than S' ?

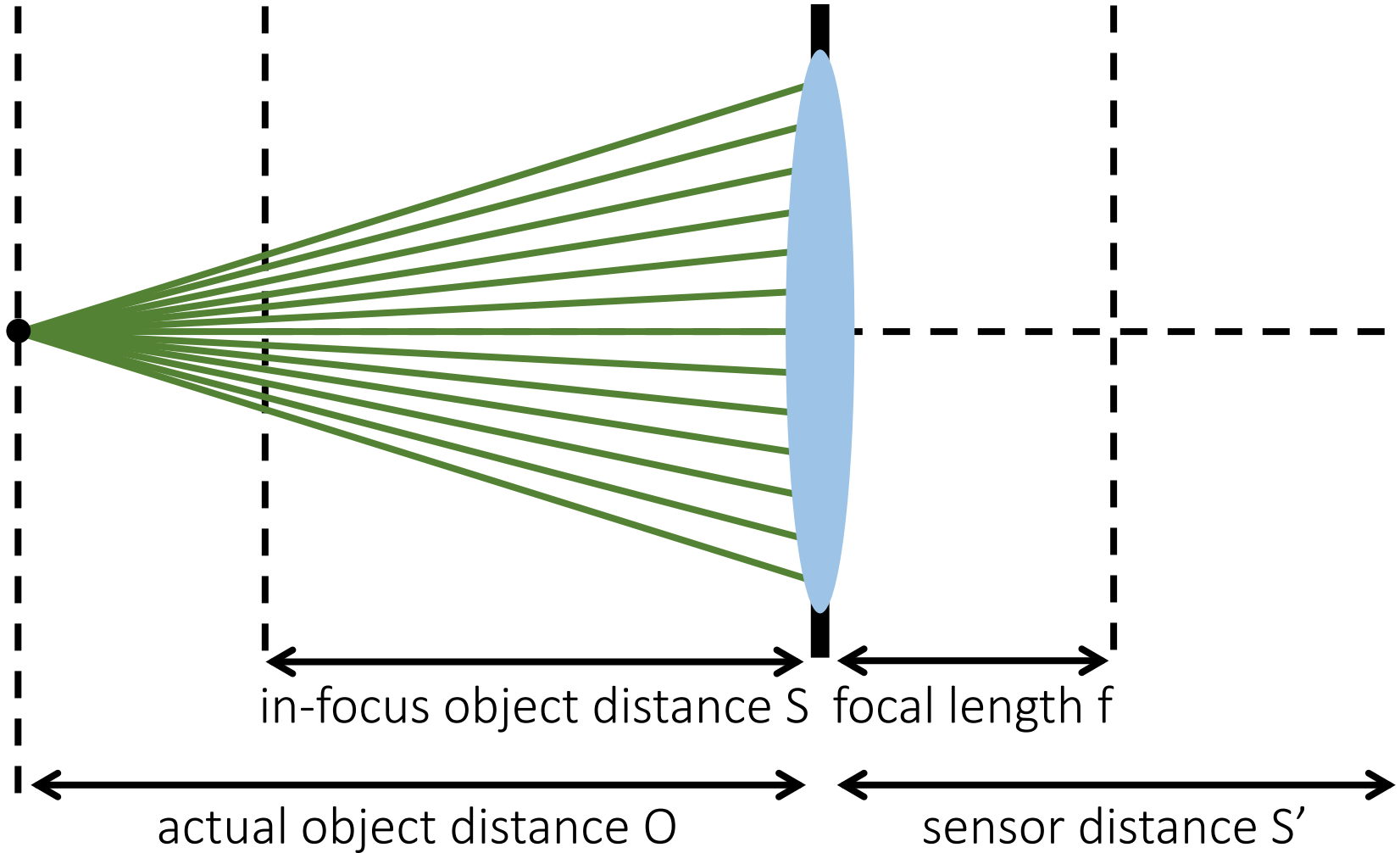

Circle of confusion

How can we compute the diameter of the circle of confusion?

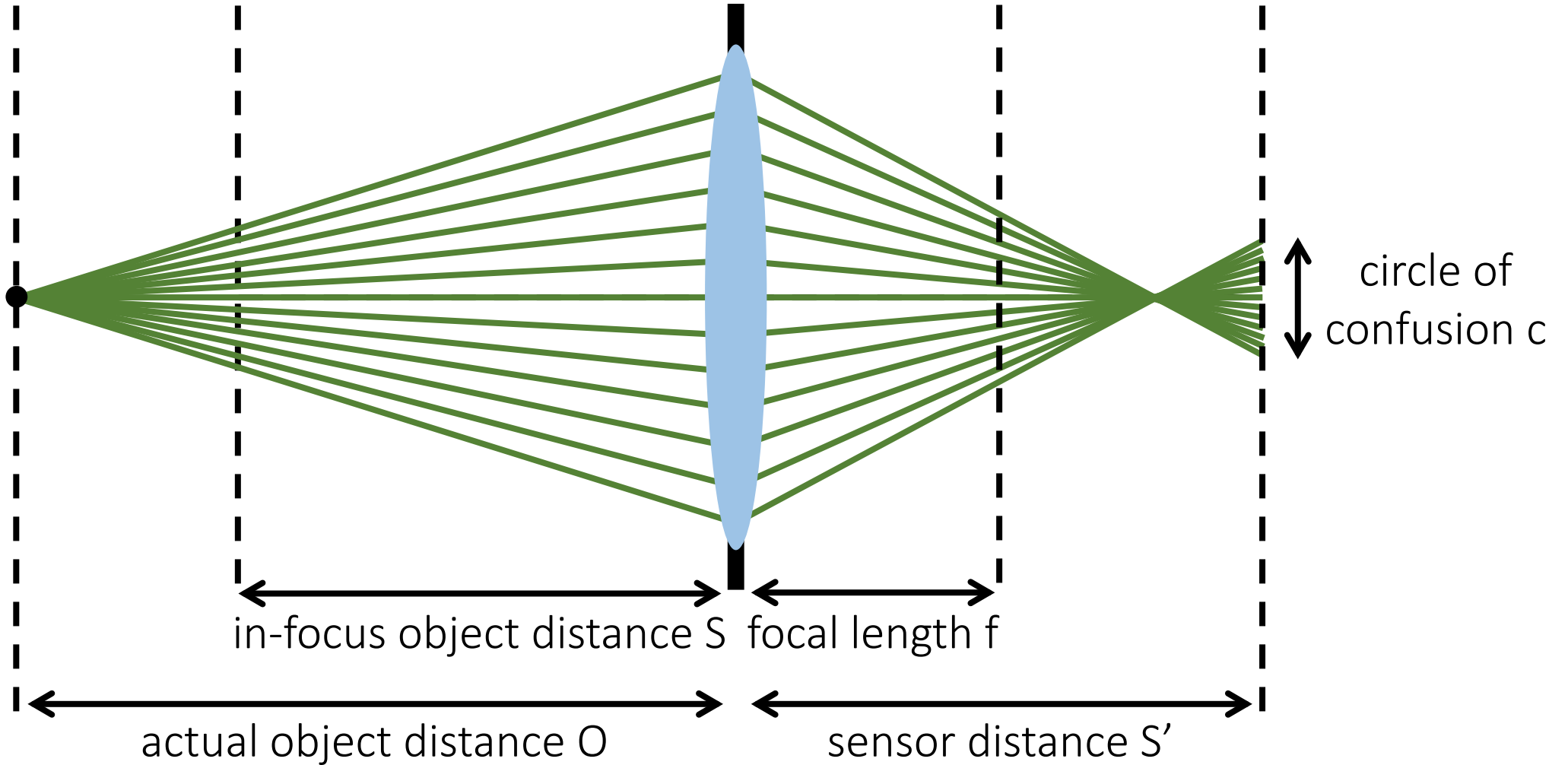

Circle of confusion

How can we compute the diameter of the circle of confusion? → Use similar triangles.

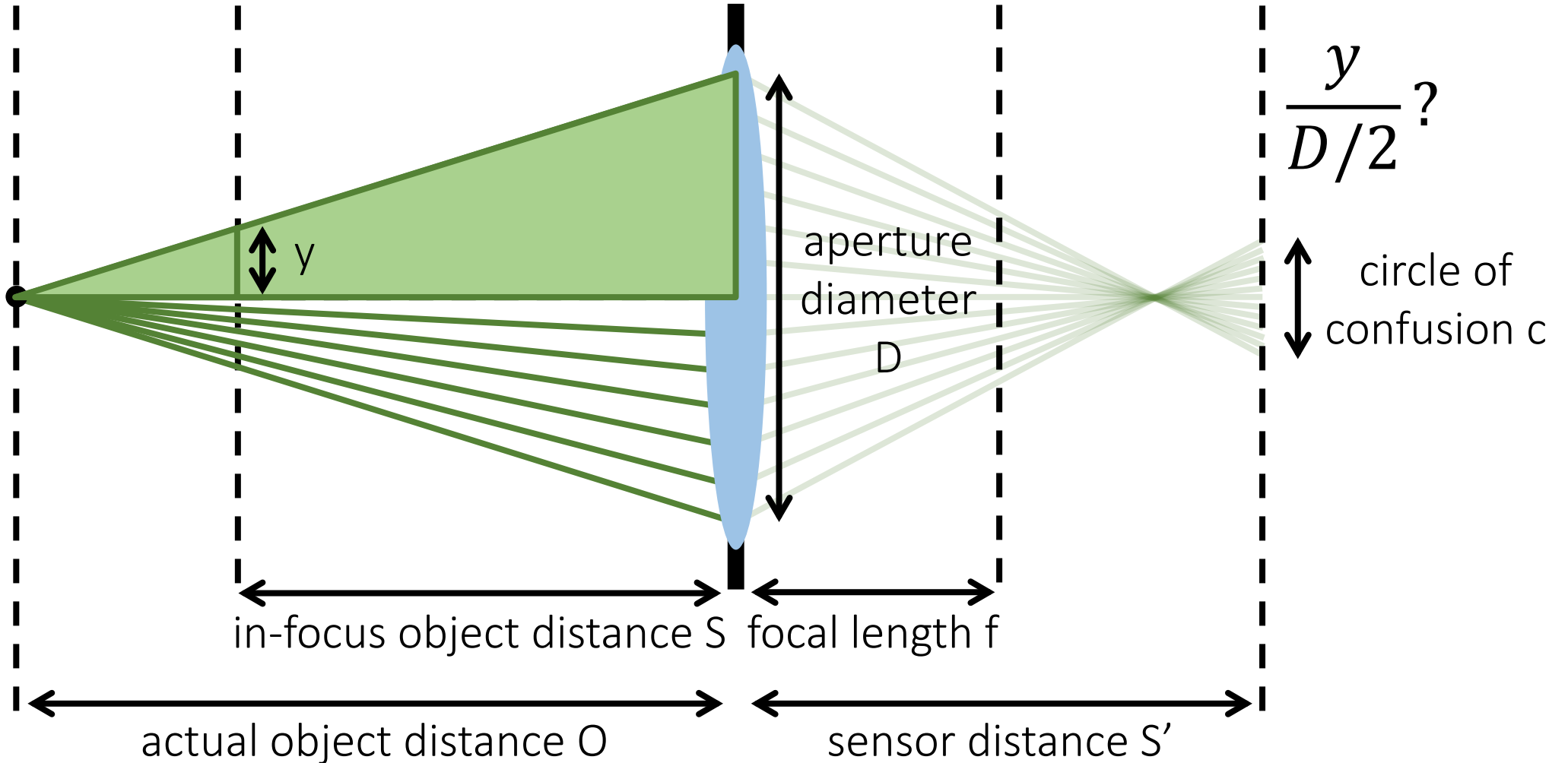

Circle of confusion

How can we compute the diameter of the circle of confusion? → Use similar triangles.

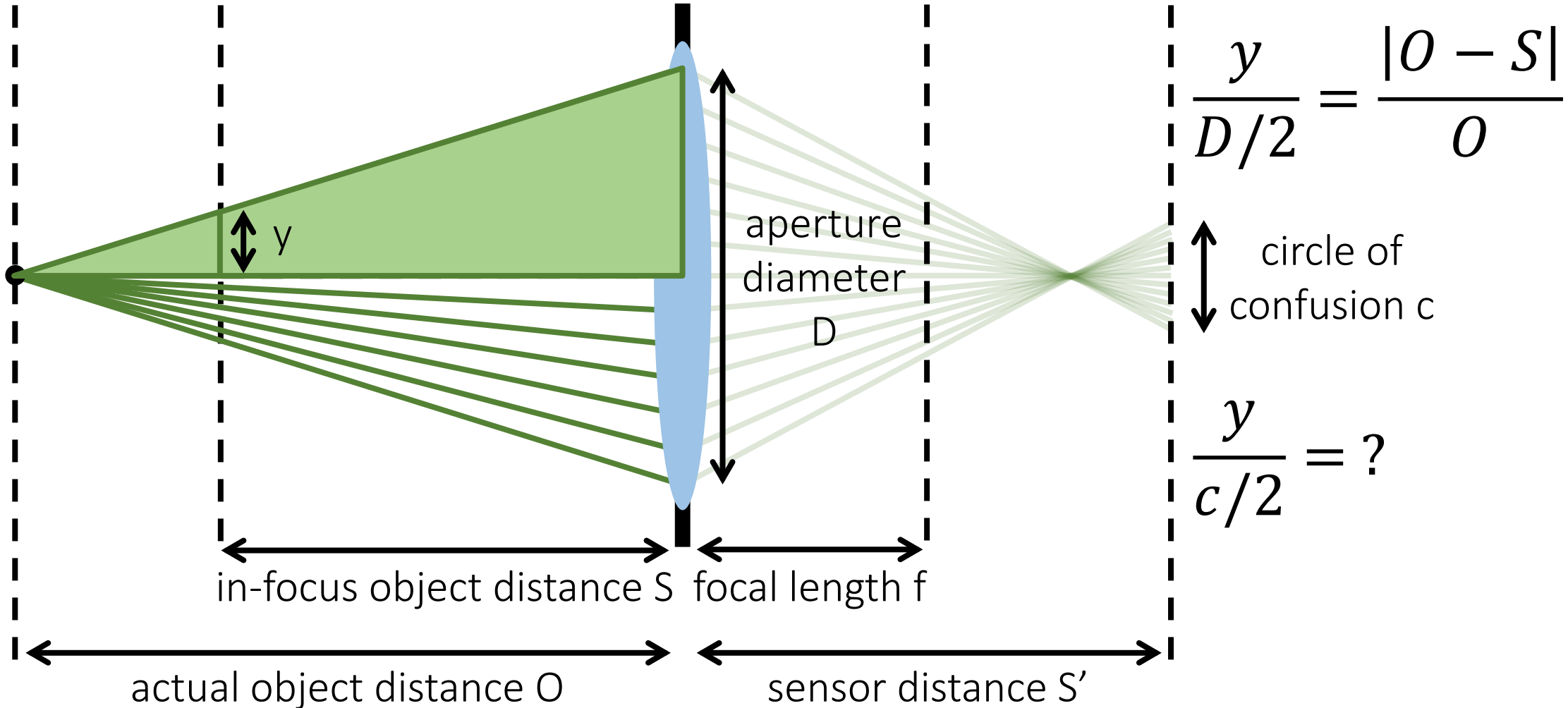

Circle of confusion

How can we compute the diameter of the circle of confusion? → Use similar triangles.

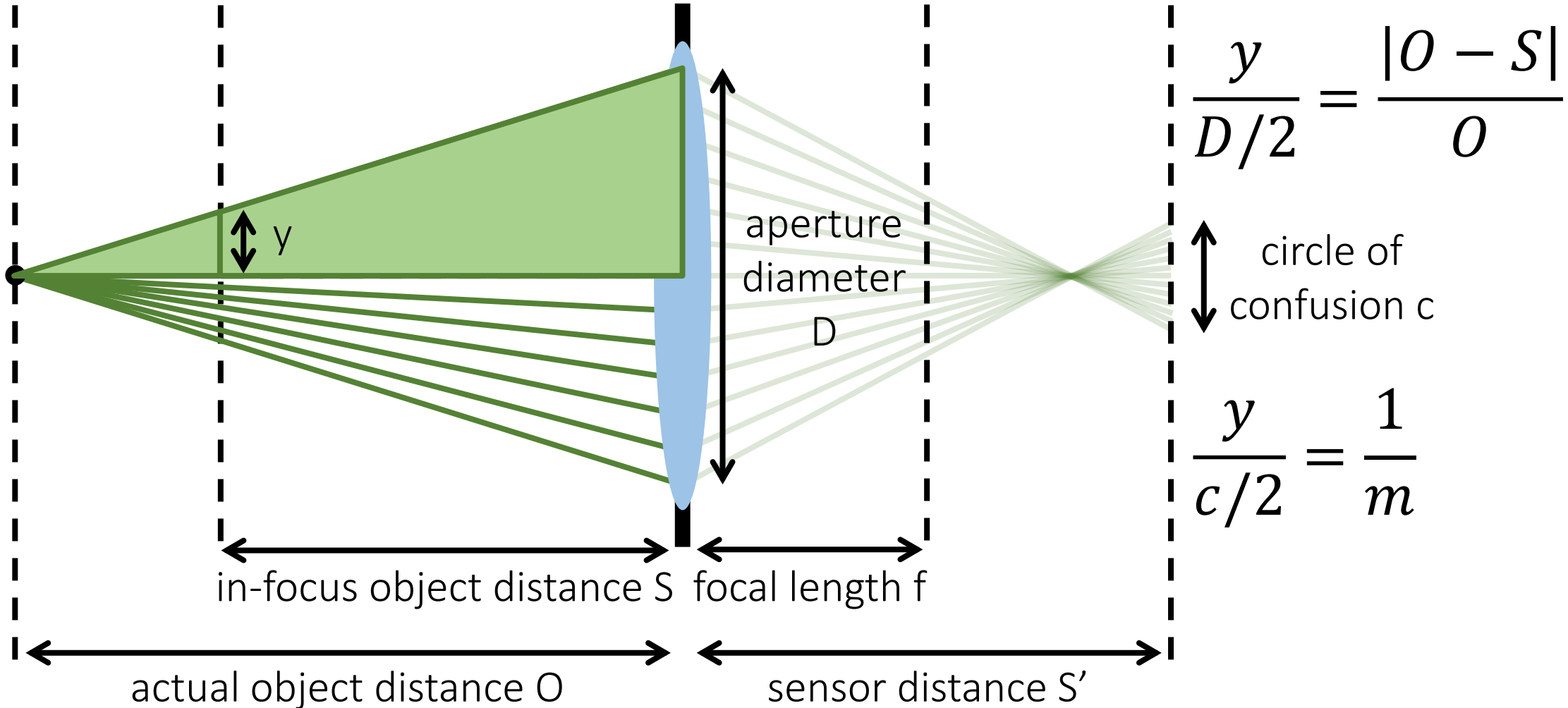

Circle of confusion

How can we compute the diameter of the circle of confusion? → Use similar triangles.

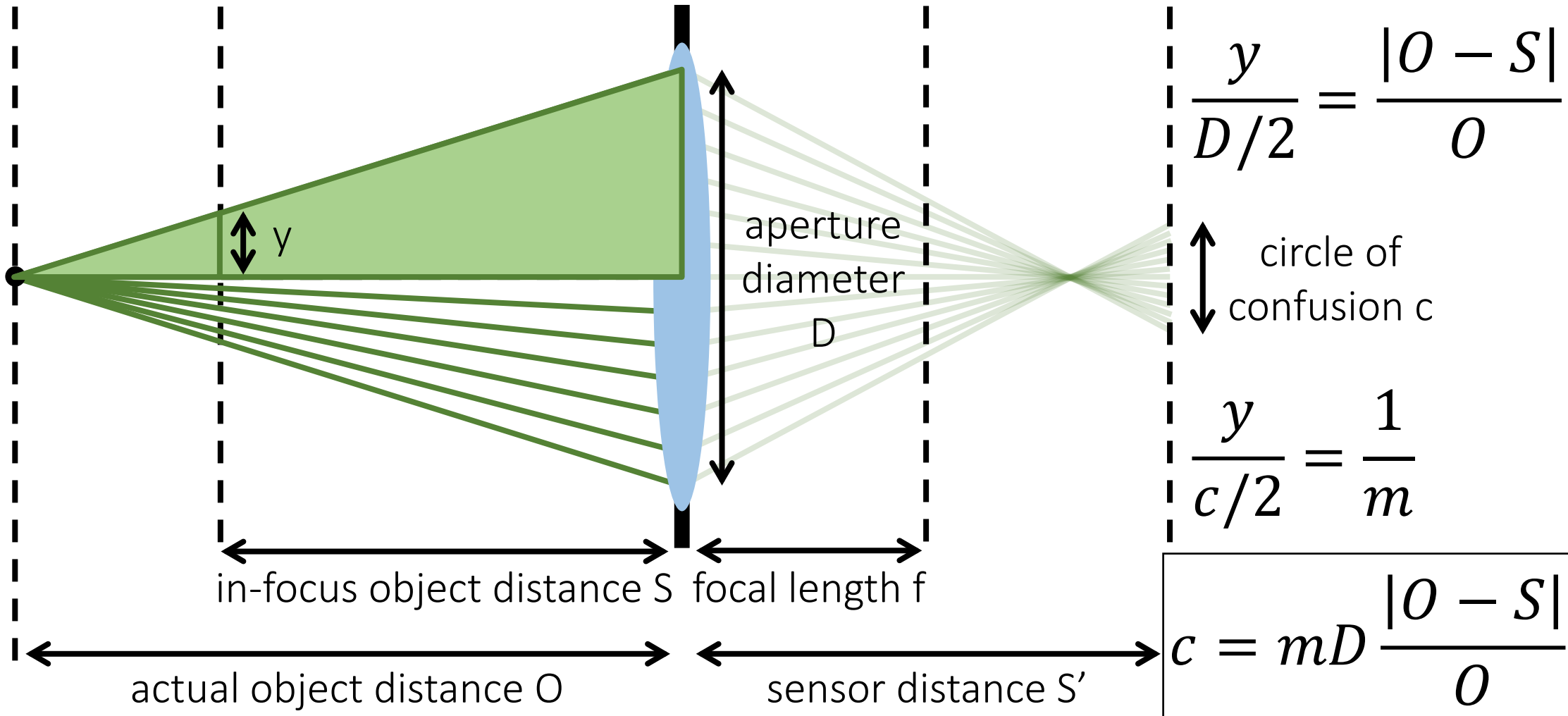

Depth of field

Distance from the in-focus object plane where the circle of confusion is *acceptably small*.

e.g., equal to
4-5 pixels

$$c < \varepsilon \Rightarrow$$

$$\text{DOF} = \frac{2\varepsilon O}{mD}$$

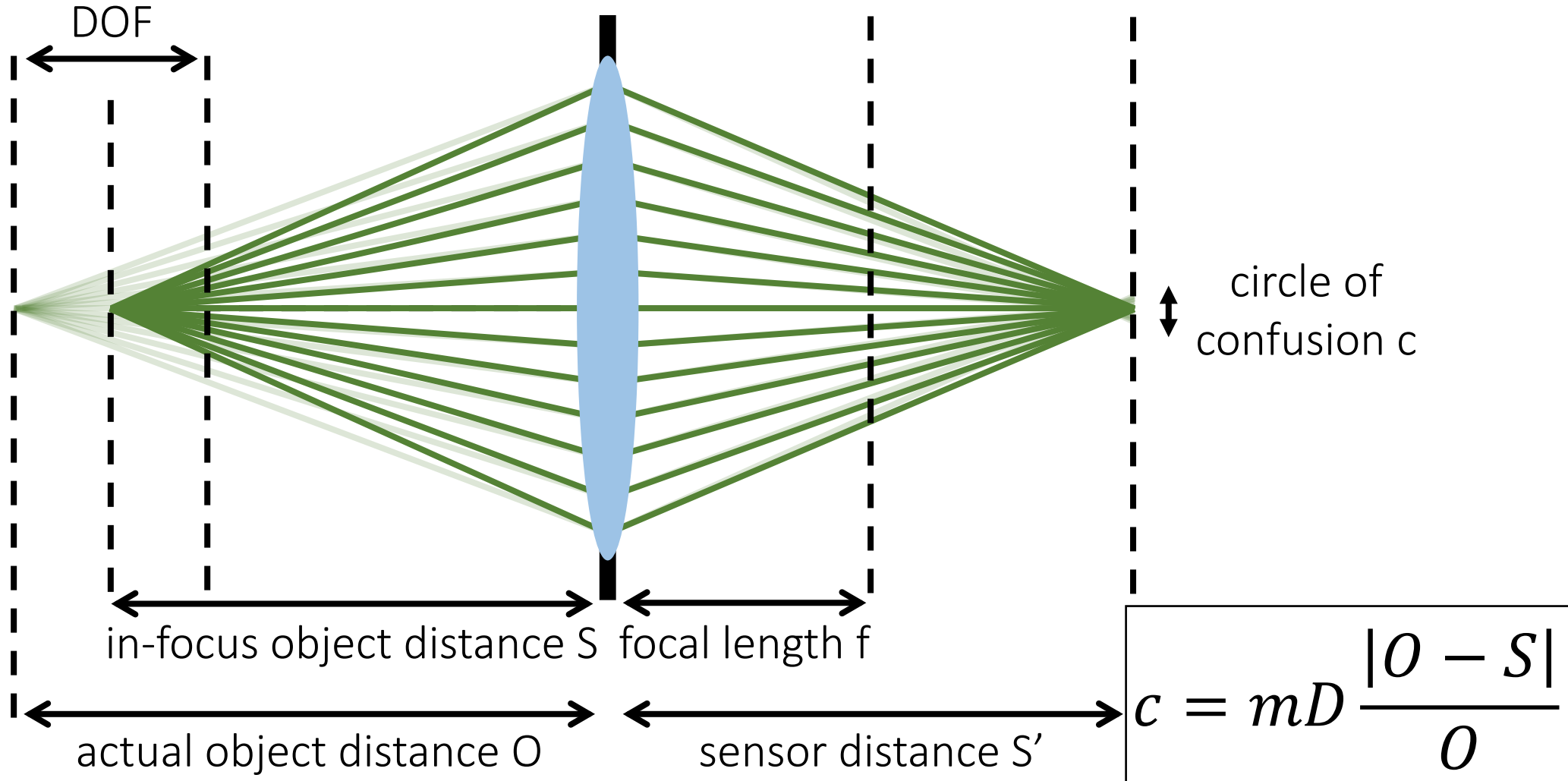

Note: in reality,
DOF is slightly
asymmetrical.

Depth of field

depth of field

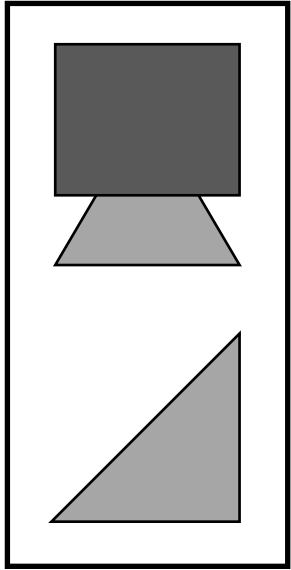
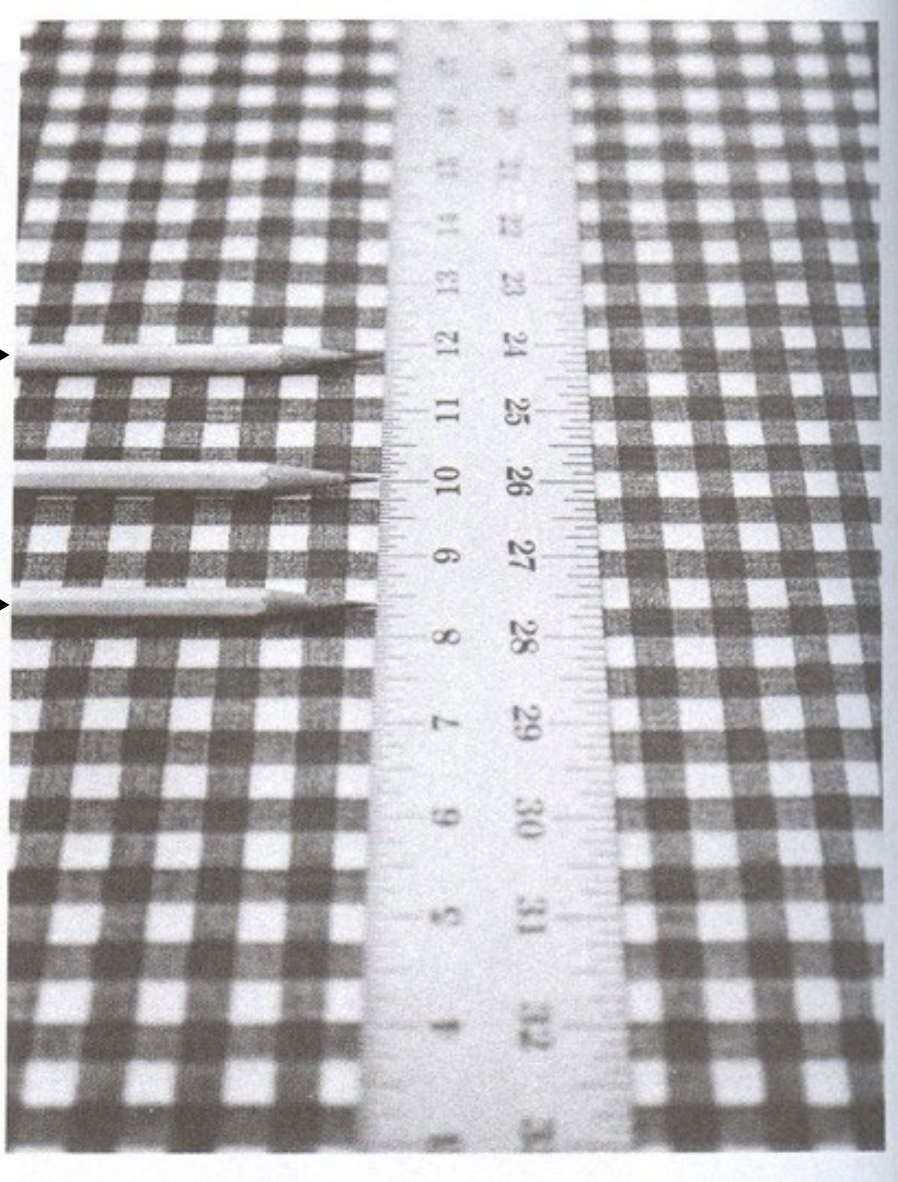
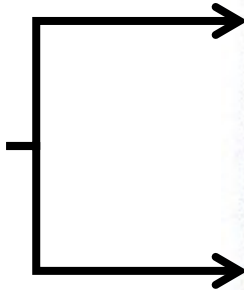

scene

Circle of Confusion

$$c = M \cdot D \cdot \frac{|S - S_1|}{S}$$

Canon 5D Mark III: $f=50\text{mm}$, $f/2.8$ ($N=2.8$),

focused at 5m , pixel size= $7.5\mu\text{m}$

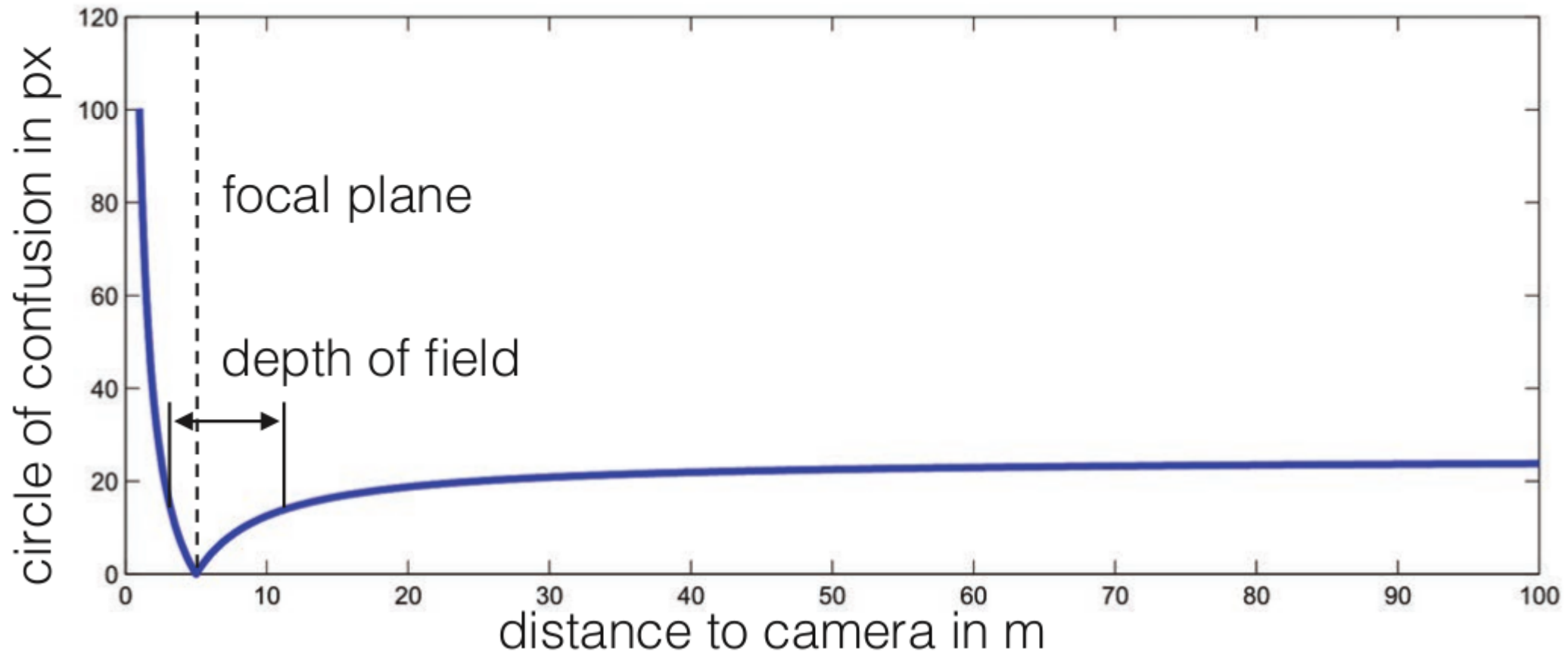

Defocus depends on aperture

What happens to the circle of confusion as the aperture diameter is reduced?

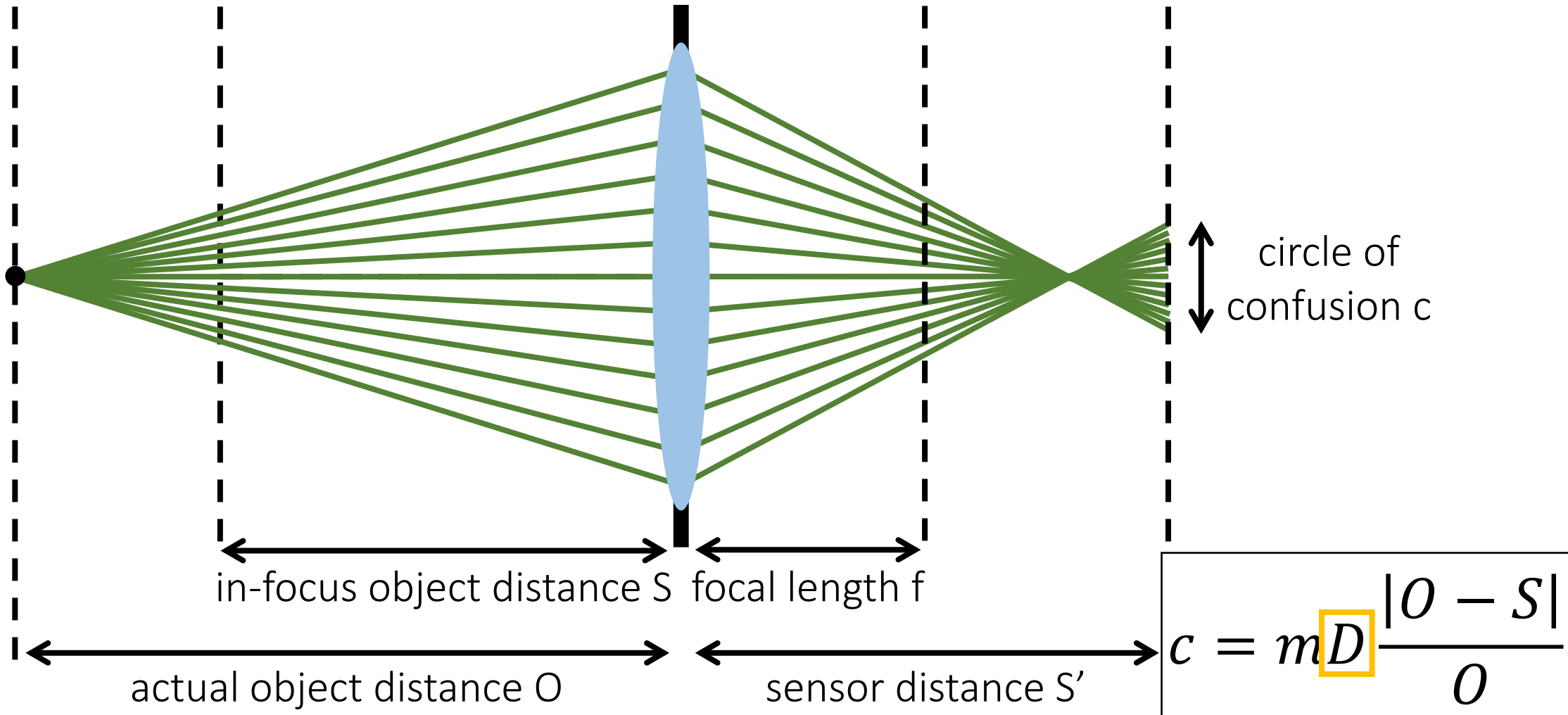

Defocus depends on aperture diameter

What happens to the circle of confusion as the aperture diameter is reduced? → It shrinks.

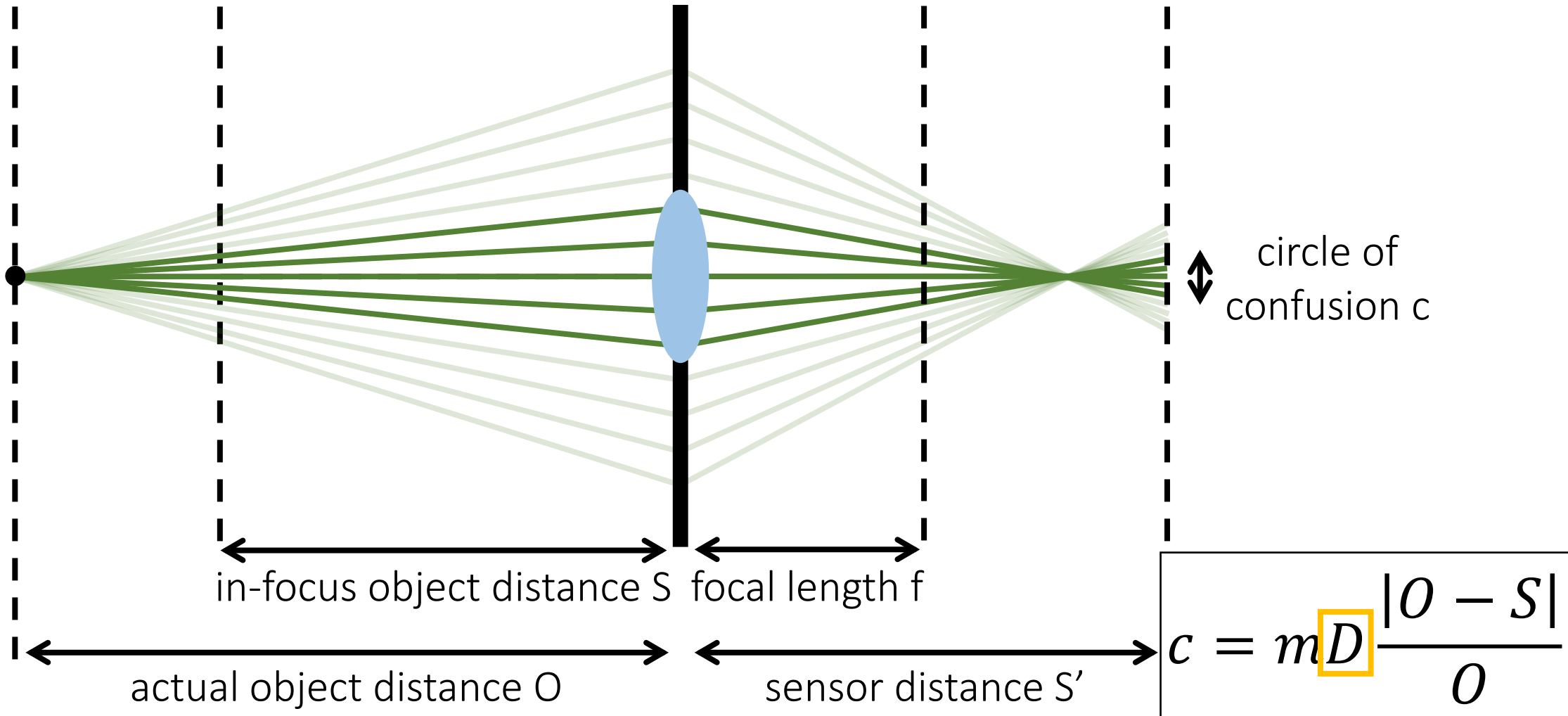

Defocus depends on aperture diameter

What happens to the depth of field as the aperture diameter is reduced?

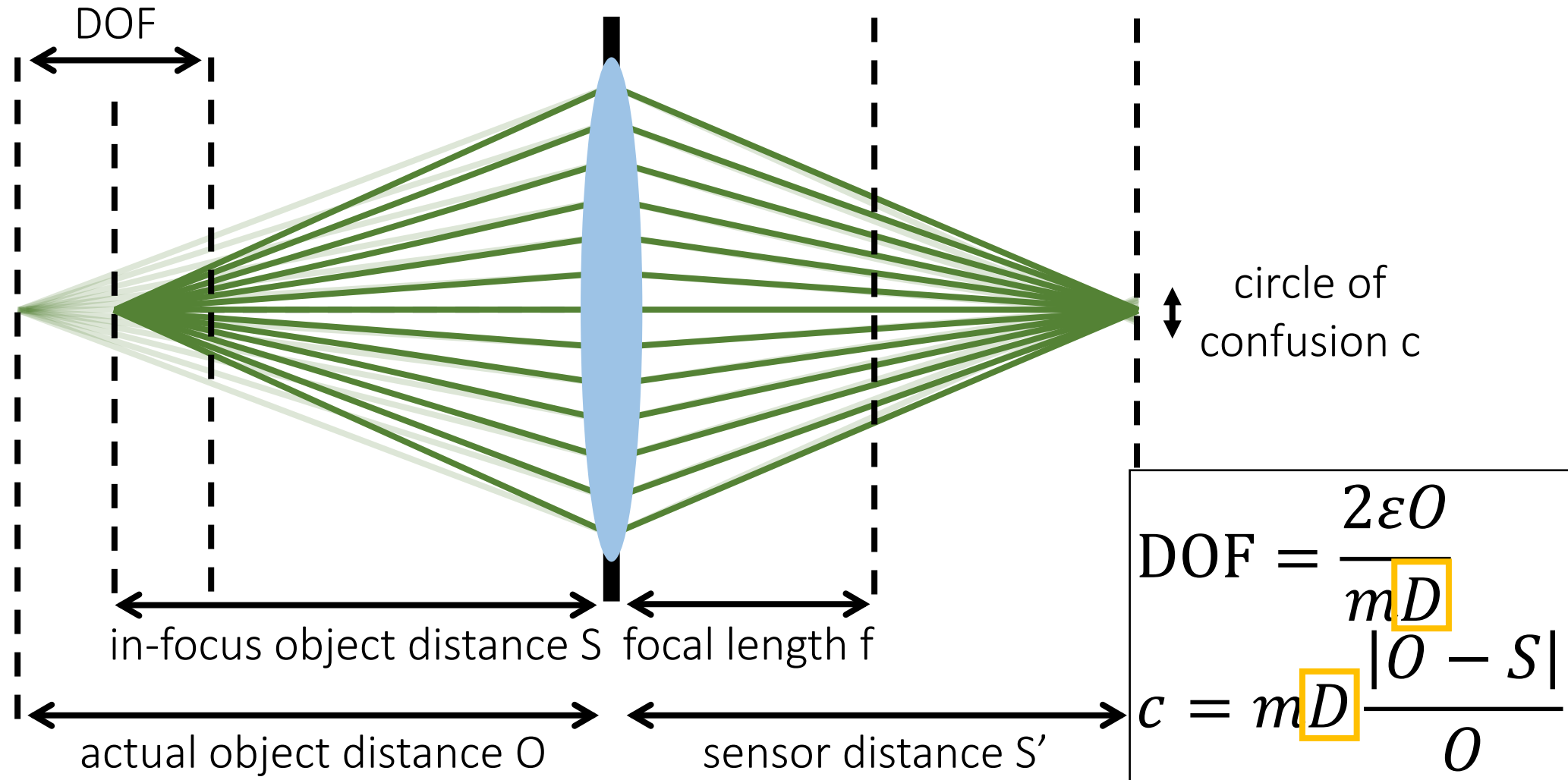

Defocus depends on aperture diameter

What happens to the depth of field as the aperture diameter is reduced? → It expands.

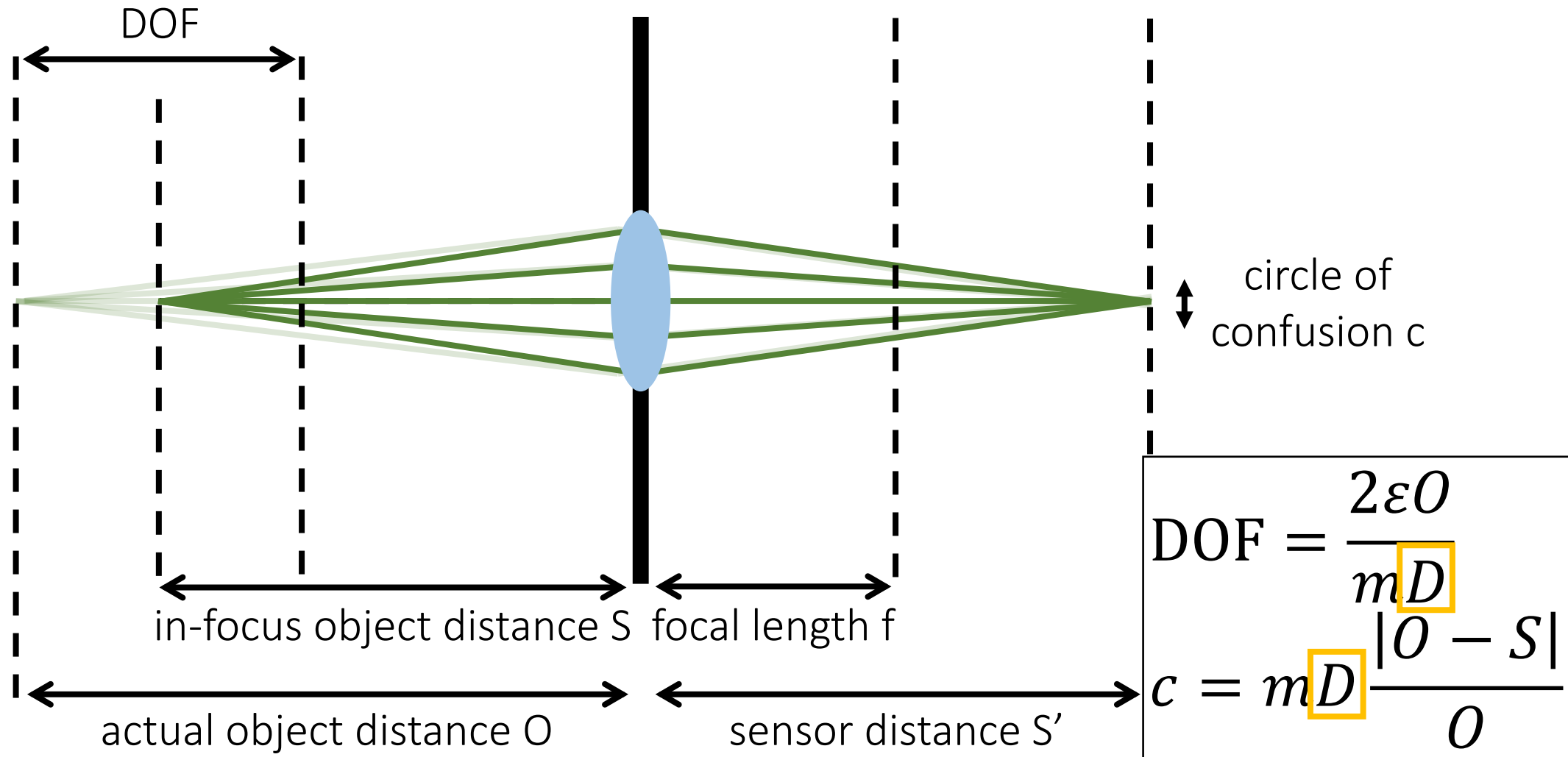

Aperture size

Most lenses have apertures of variable size.

- The size of the aperture is expressed as the “f-number”: The bigger this number, the smaller the aperture.



f / 1.4



f / 2.8



f / 4



f / 8



f / 16

You can see the aperture by removing the lens and looking inside it.

Demonstration

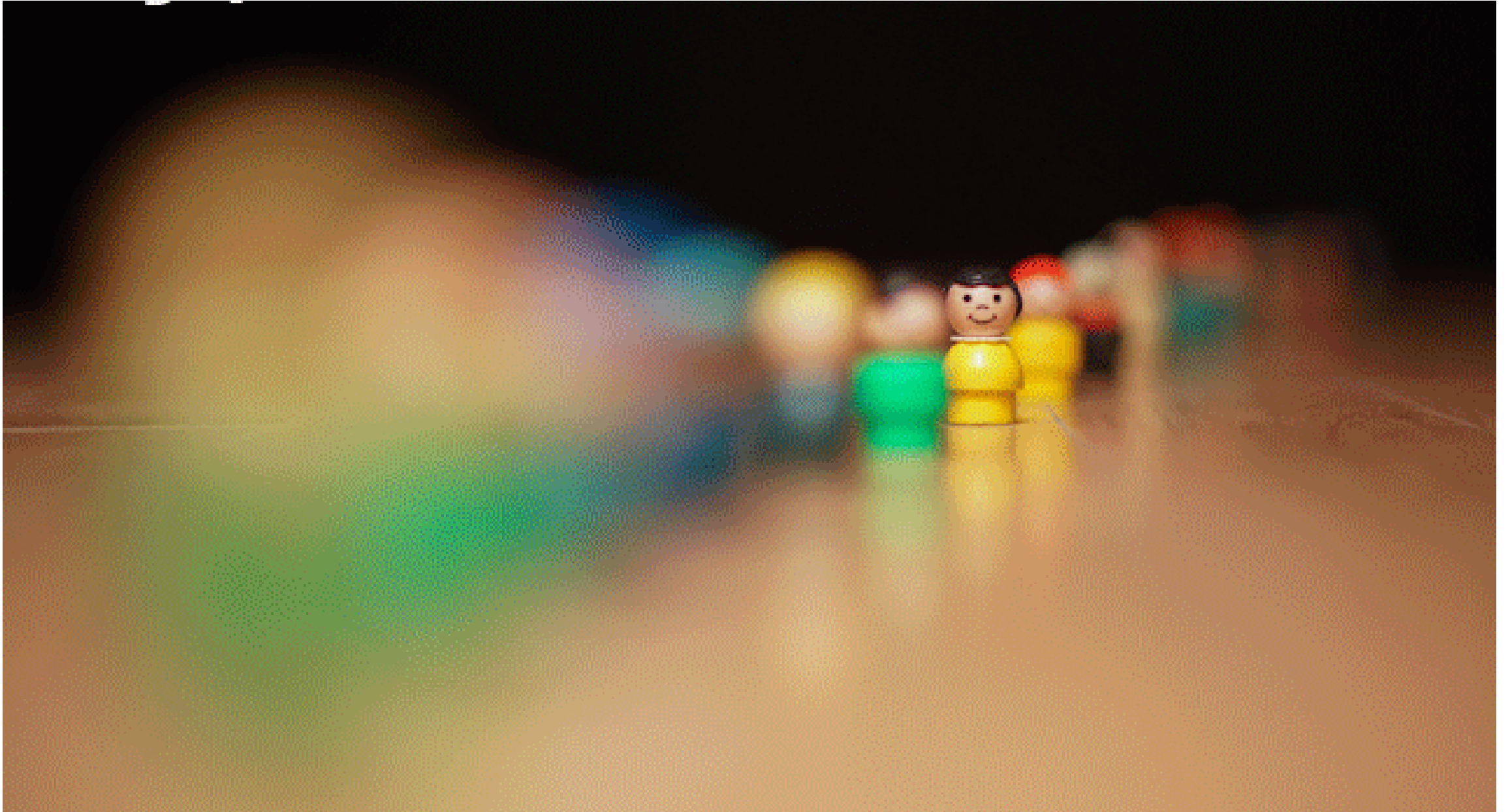

Depth of field

Form of defocus blur is determined by shape of aperture.

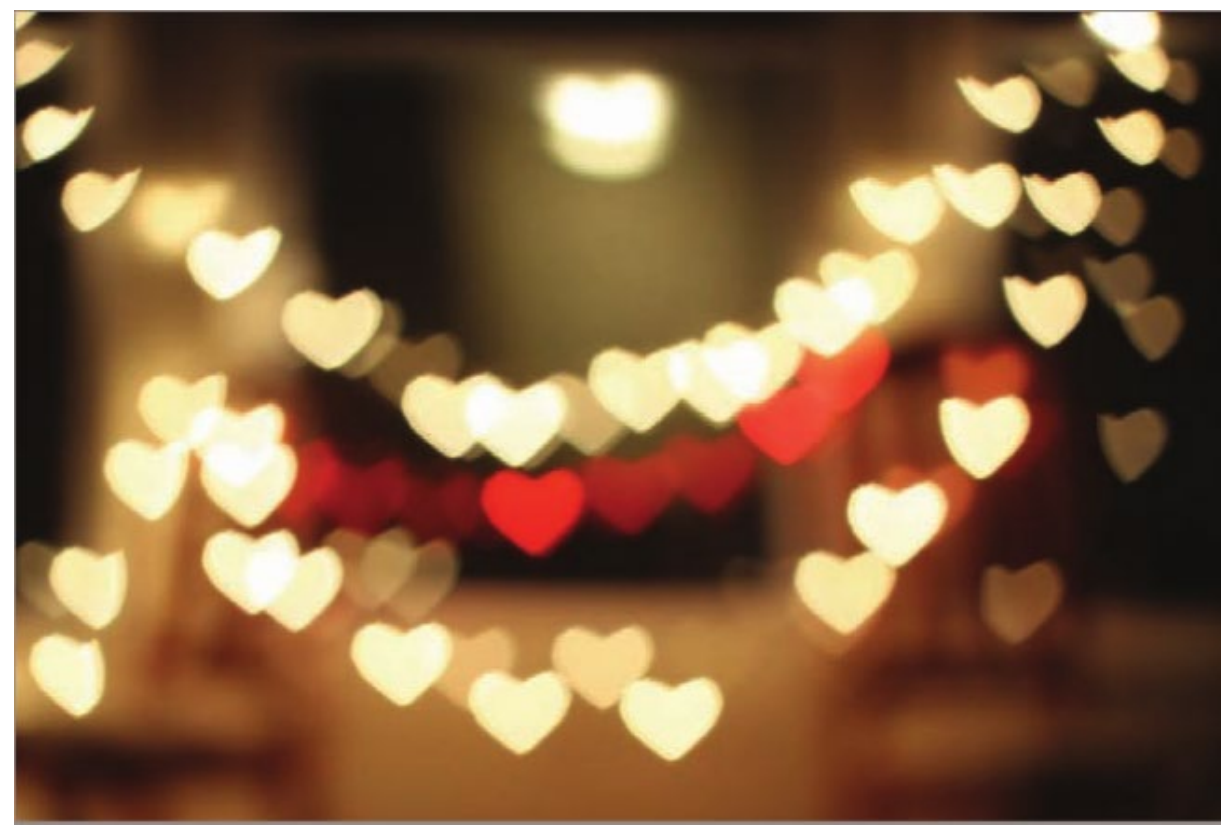

Defocus depends on aperture diameter

If small aperture sizes reduce defocus blur, should we always use the smallest aperture?

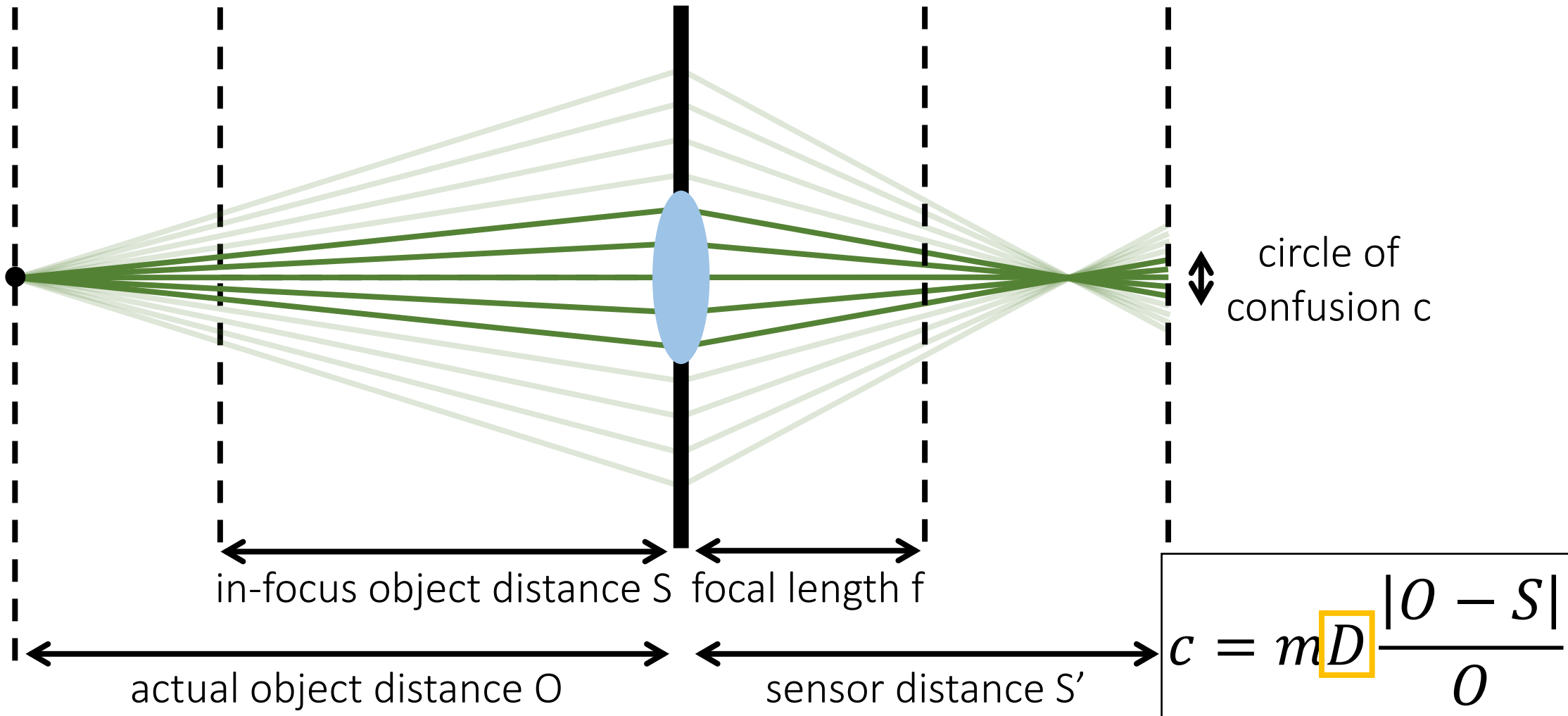

Bokeh

Sharp depth of field (“bokeh”) is often desirable.



What happens as the aperture keeps getting smaller?

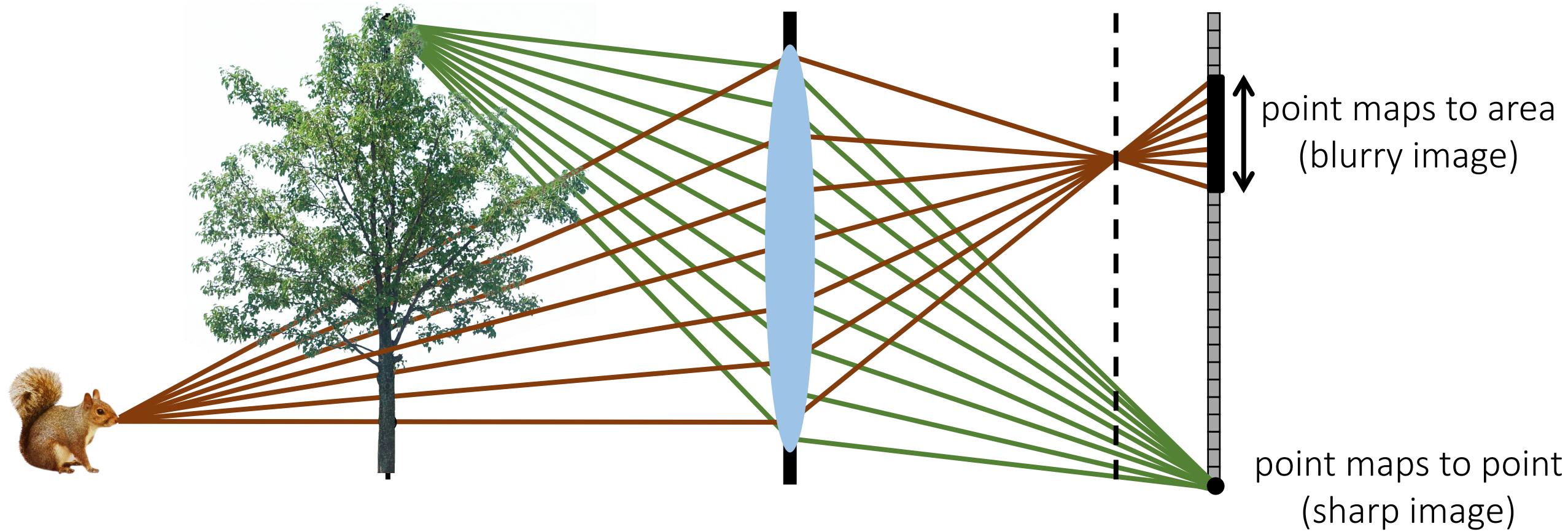

What happens as the aperture keeps getting smaller?

Lens becomes equivalent to a pinhole.

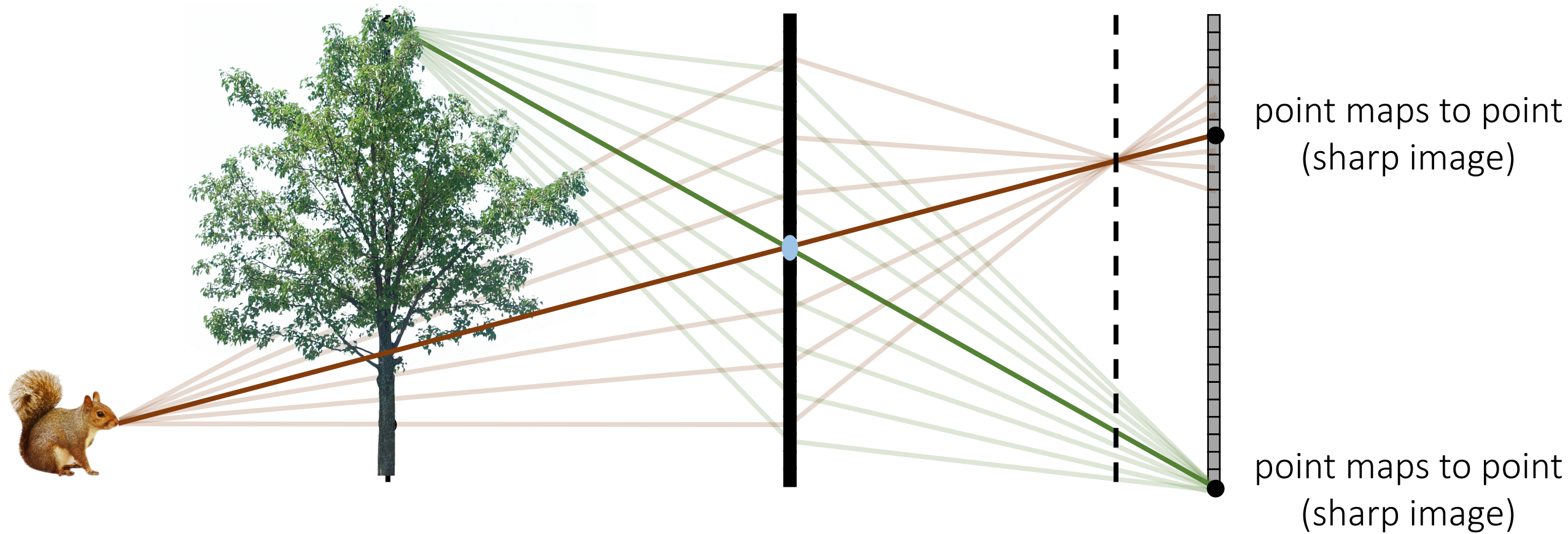

- No defocus, everything is sharp regardless of depth.
- Very little light, signal-to-noise ratio is just as bad as pinhole.

Lens camera and pinhole camera

The lens camera

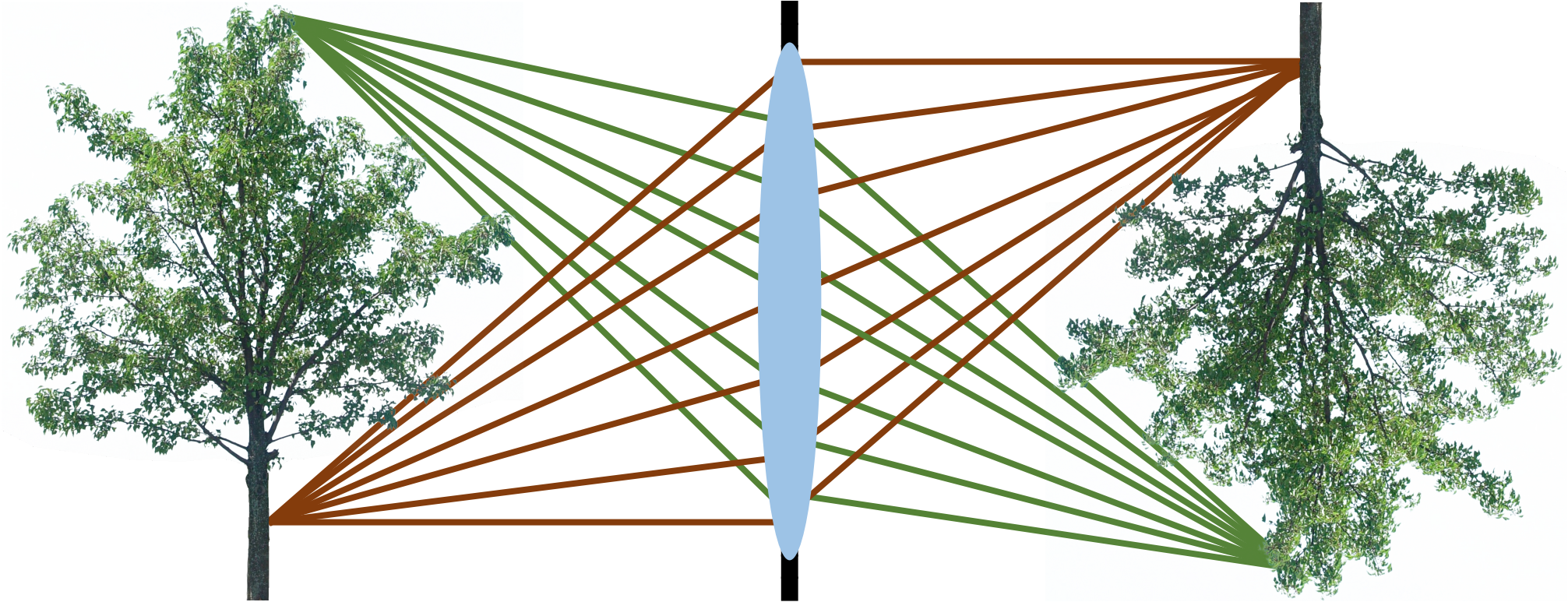

The pinhole camera

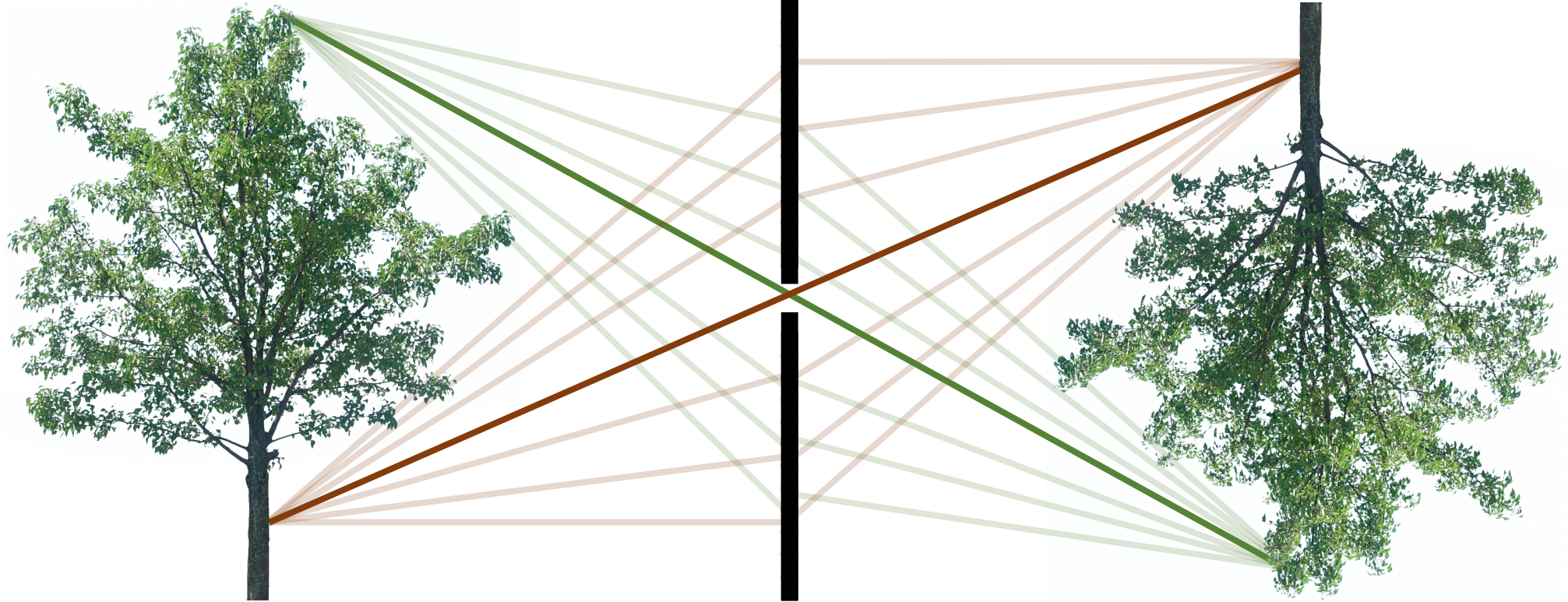

The pinhole camera

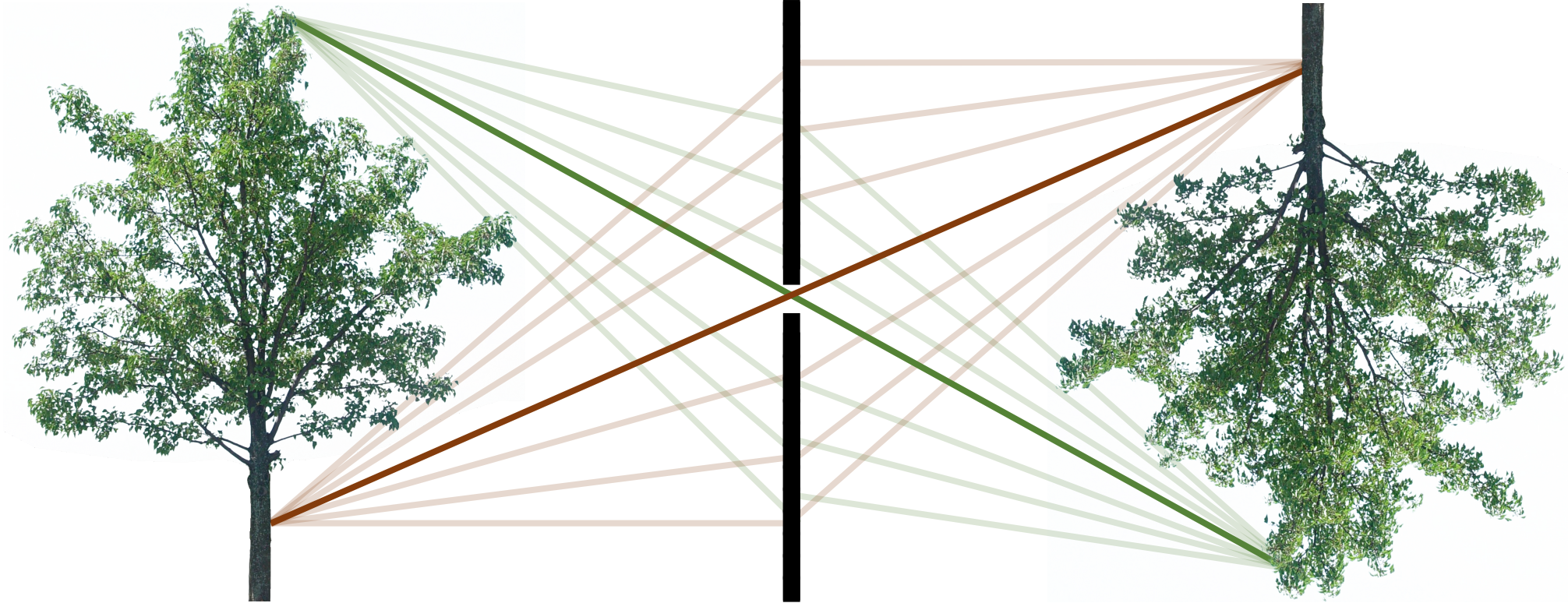

Central rays propagate in the same way for both models!

Describing both lens and pinhole cameras

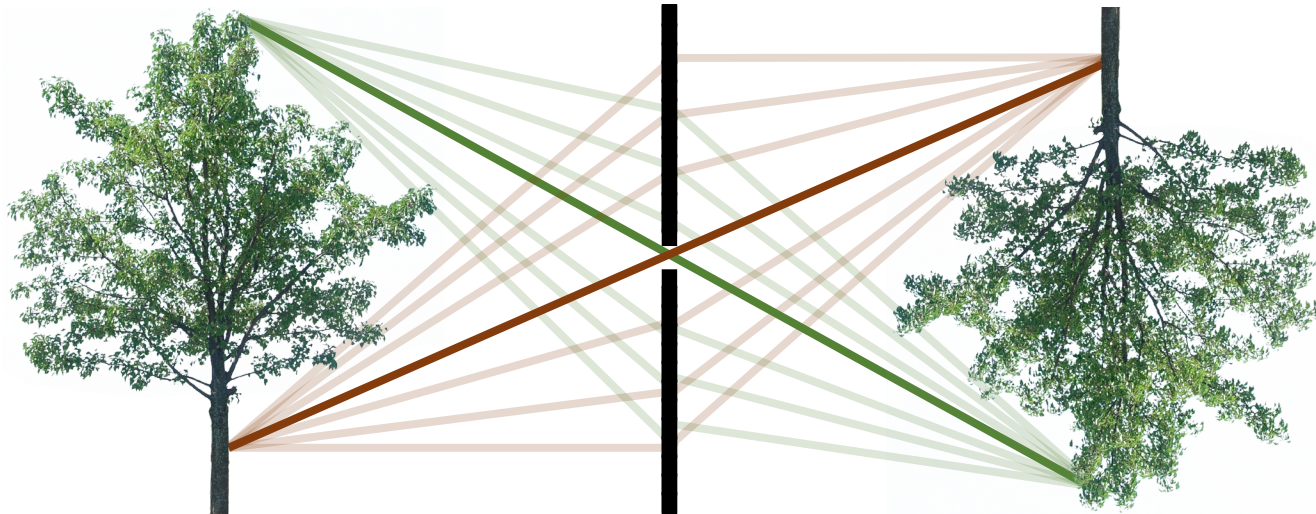
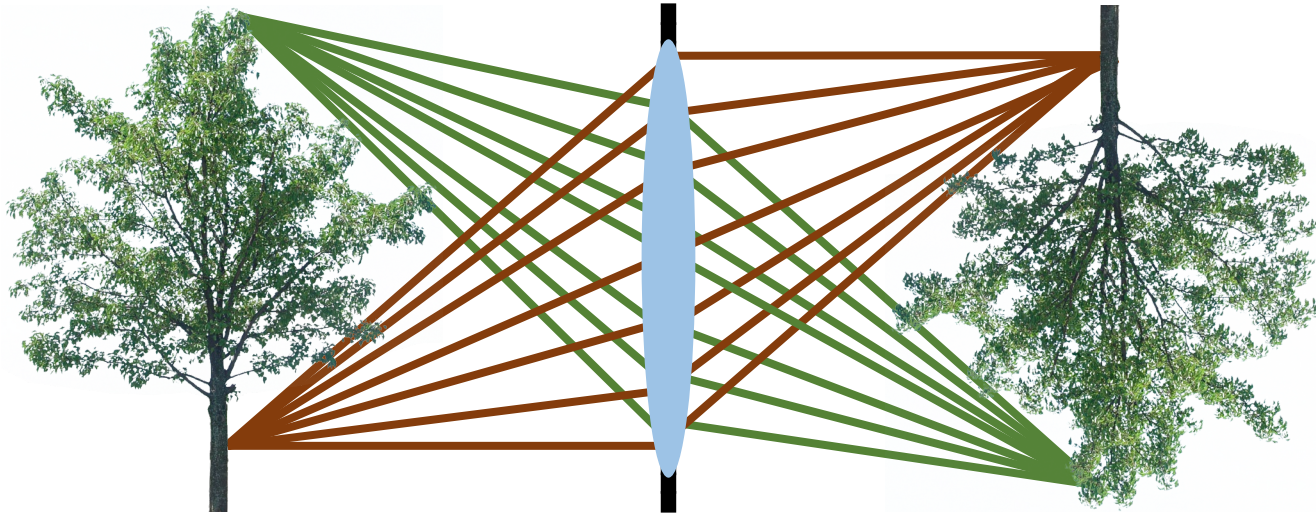

We can derive properties and descriptions that hold for both camera models if:

- We consider only central rays.
- We assume that everything of interest in the scene is within the depth of field.

Important difference: focal length

In a pinhole camera, focal length is distance between aperture and sensor

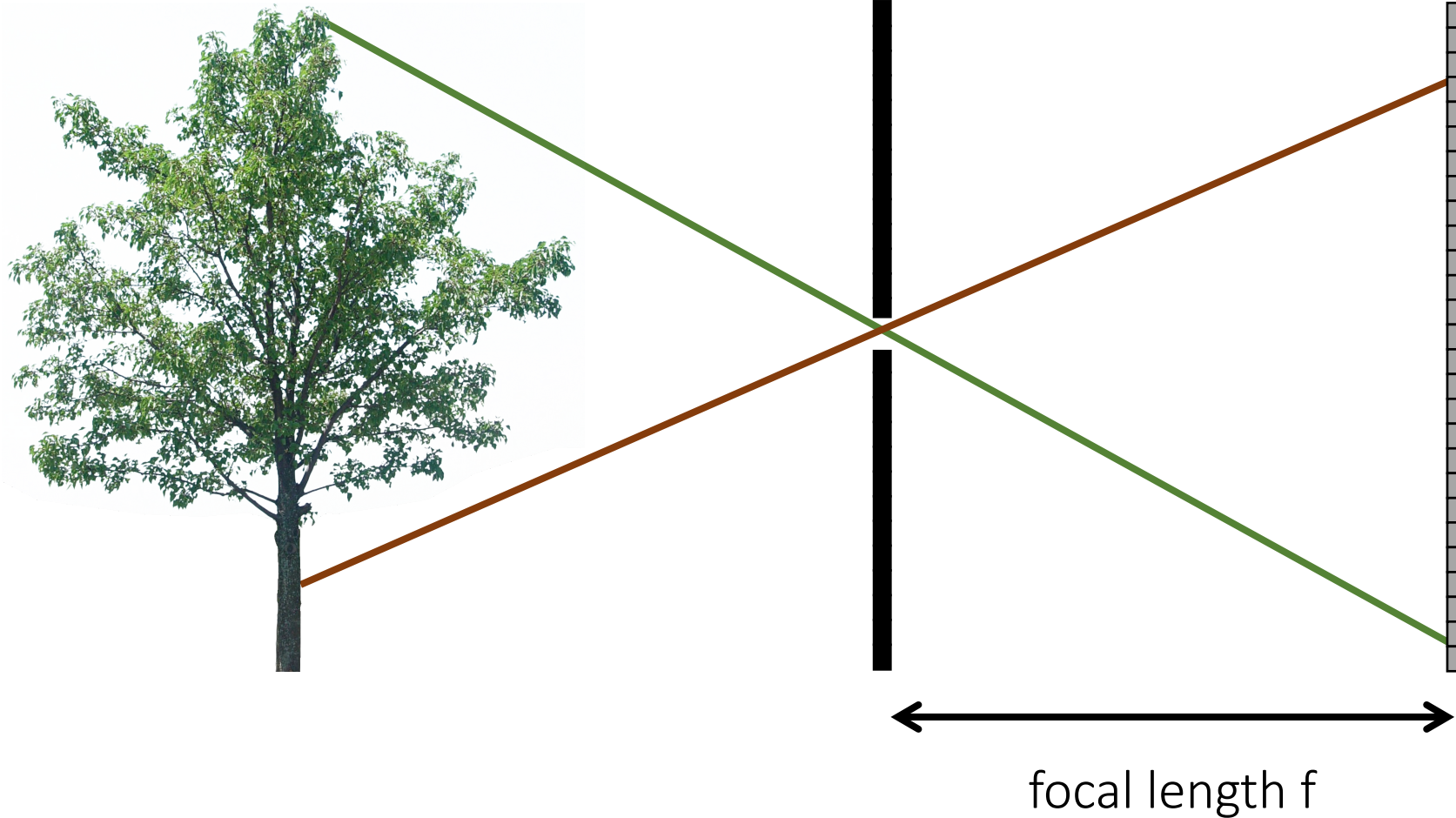

Important difference: focal length

In a lens camera, focal length is distance where parallel rays intersect

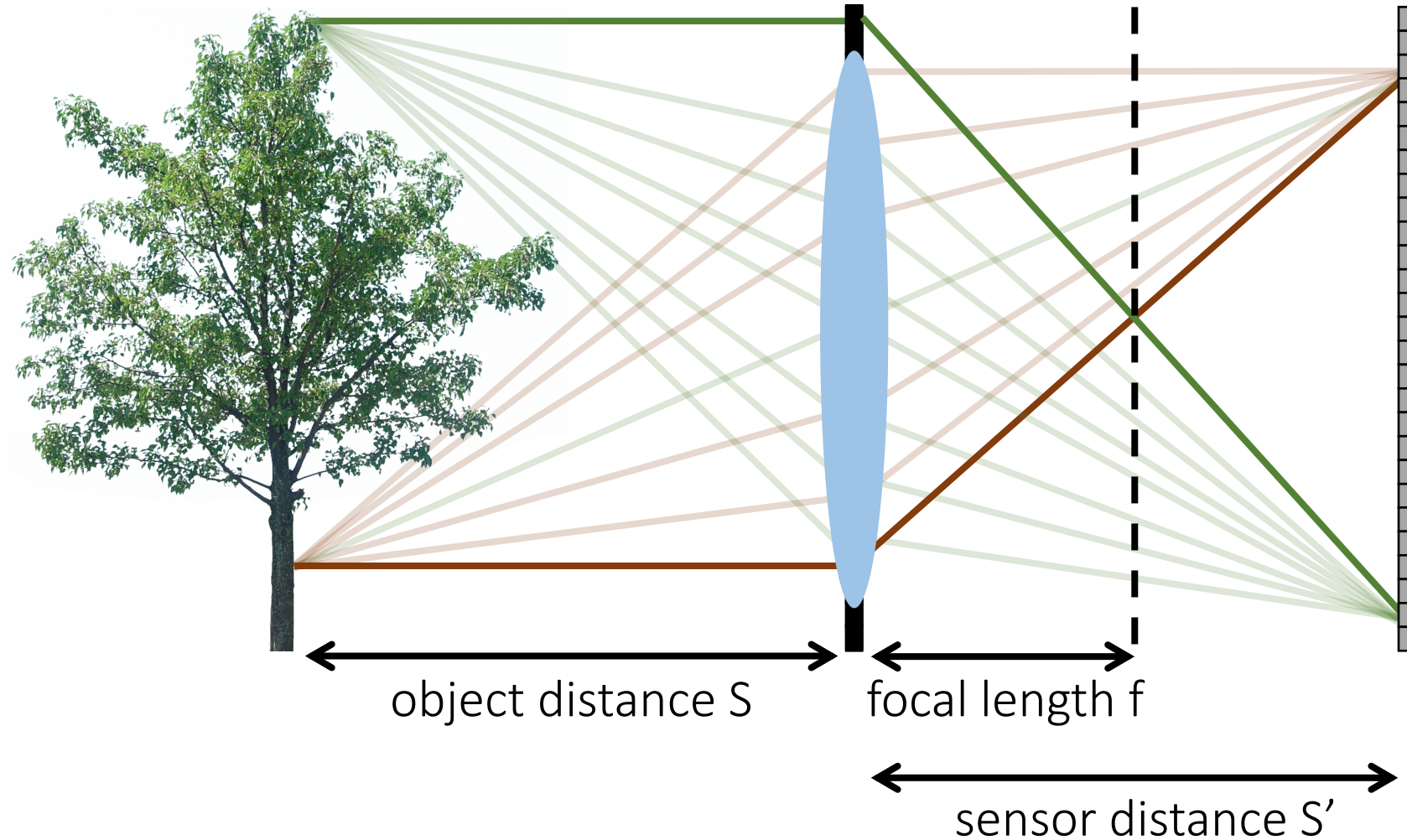

Describing both lens and pinhole cameras

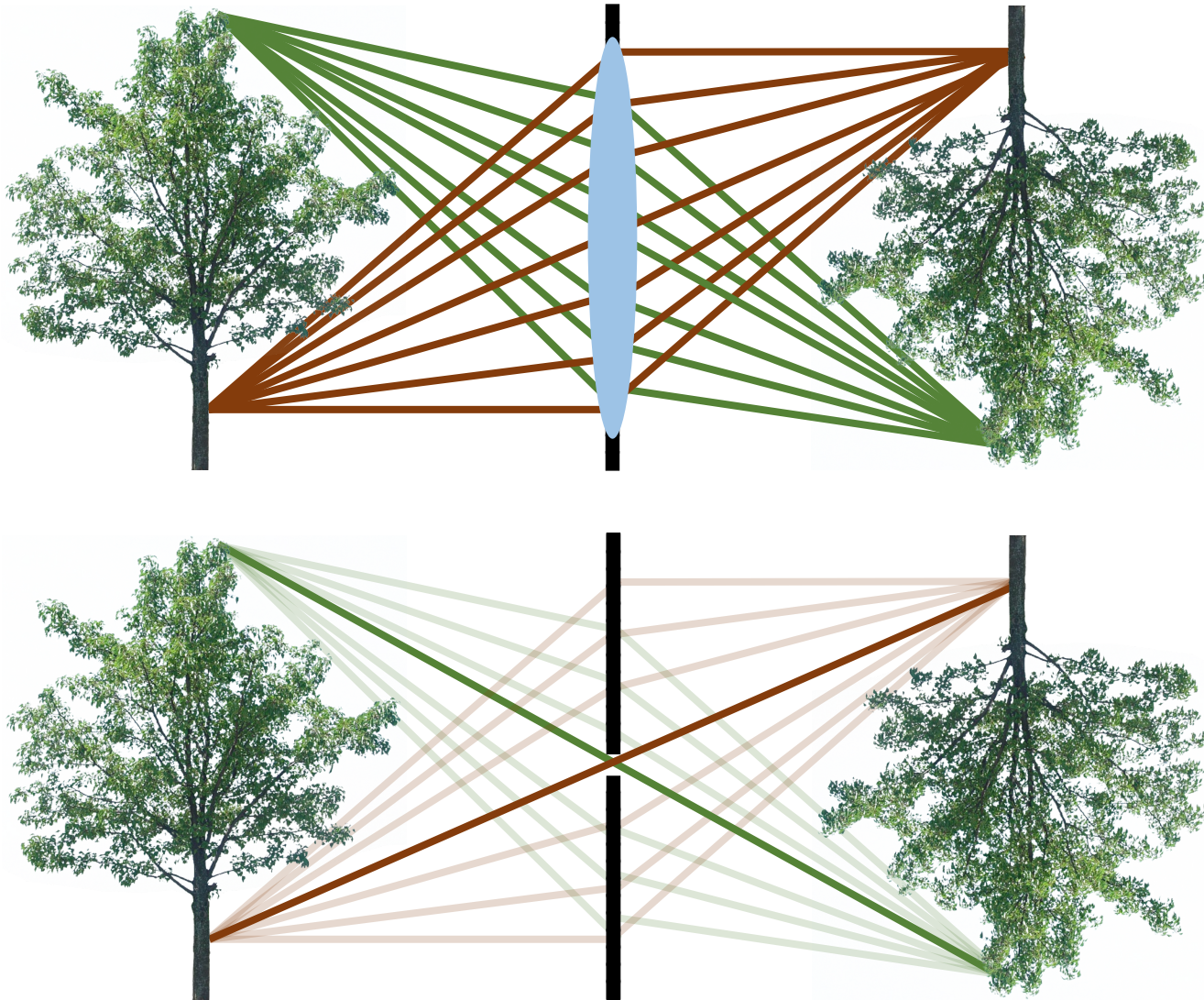

We can derive properties and descriptions that hold for both camera models if:

- We consider only central rays.
- We assume everything of interest in the scene is within the depth of field.
- We assume that the focus distance of the lens camera is equal to the focal length of the pinhole camera.

Effect of aperture size on lens and pinhole cameras

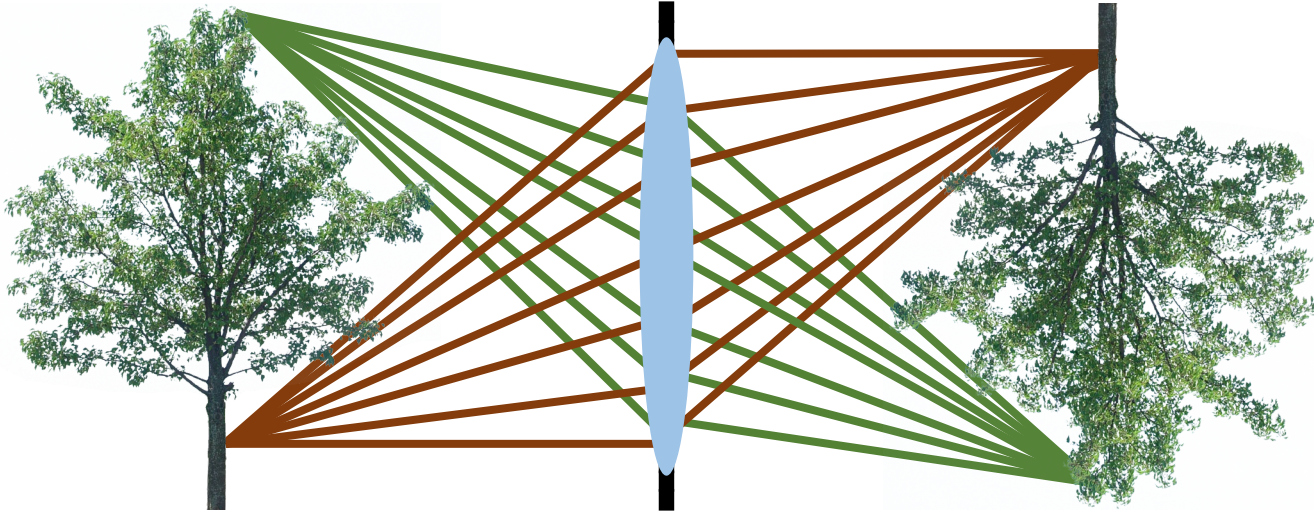

Doubling the aperture diameter:

- Increases light throughput by four times.
- Increases circle of confusion for out-of-focus plane by two times.
- Decreases depth of field by two times.

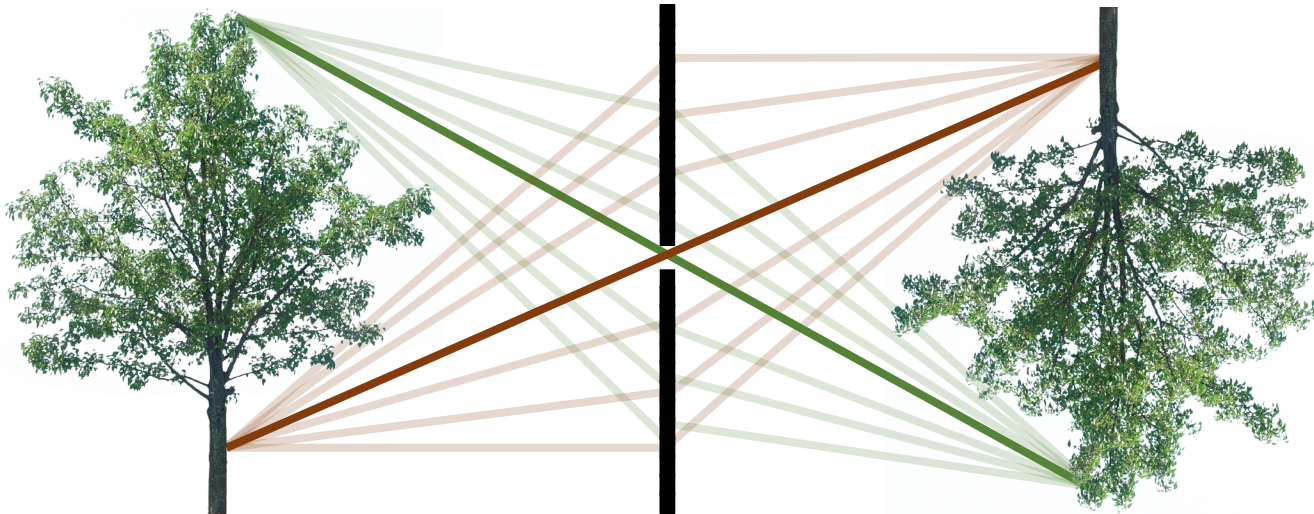

Doubling the aperture diameter:

- Increases light throughput by four times.
- Increases circle of confusion for all planes by two times.

Field of view

What happens as you take a closer look?



Field of view

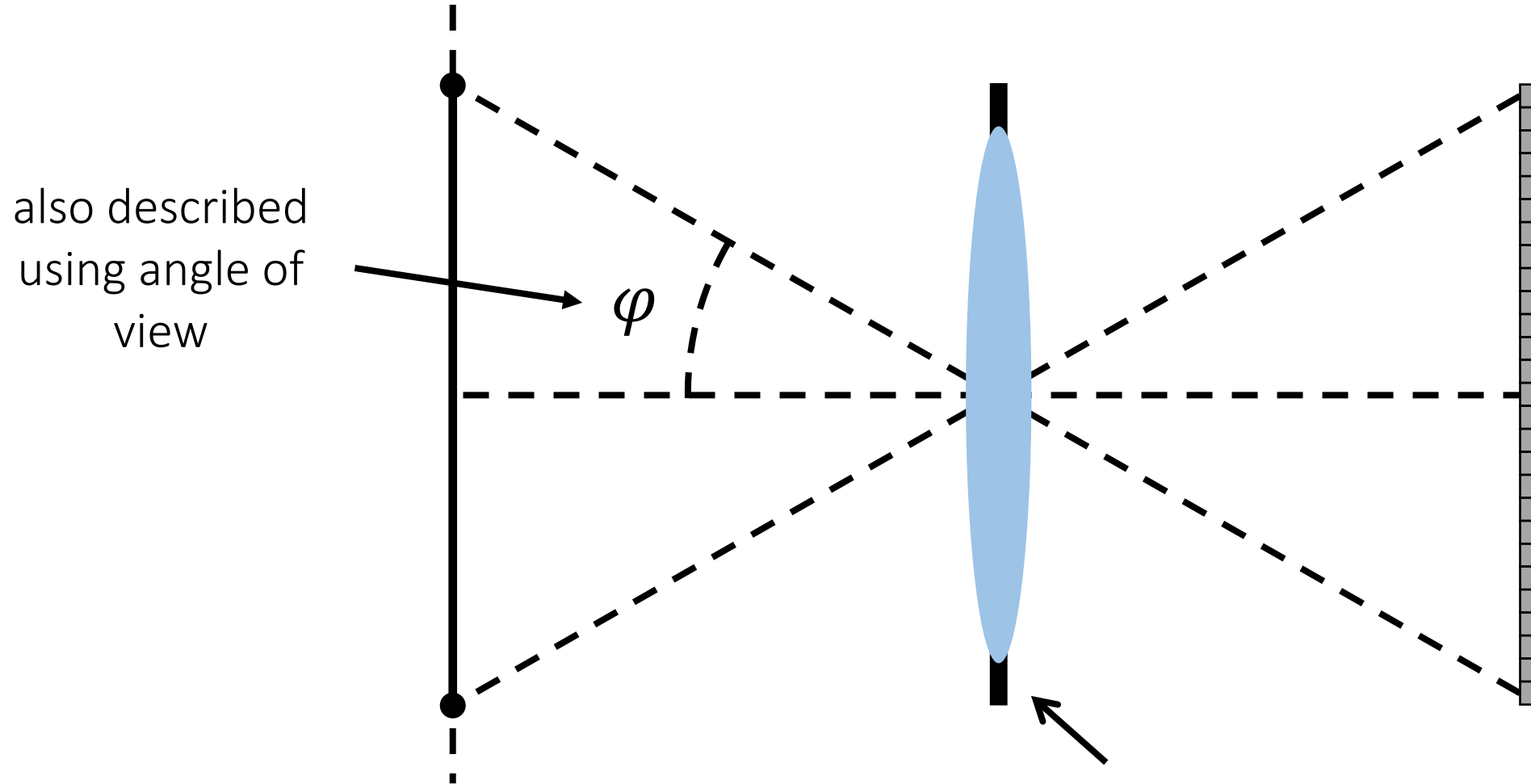

Note: here I drew a lens, but I could have just as well drawn a pinhole

Field of view

The part of the in-focus plane that gets mapped on the sensor.

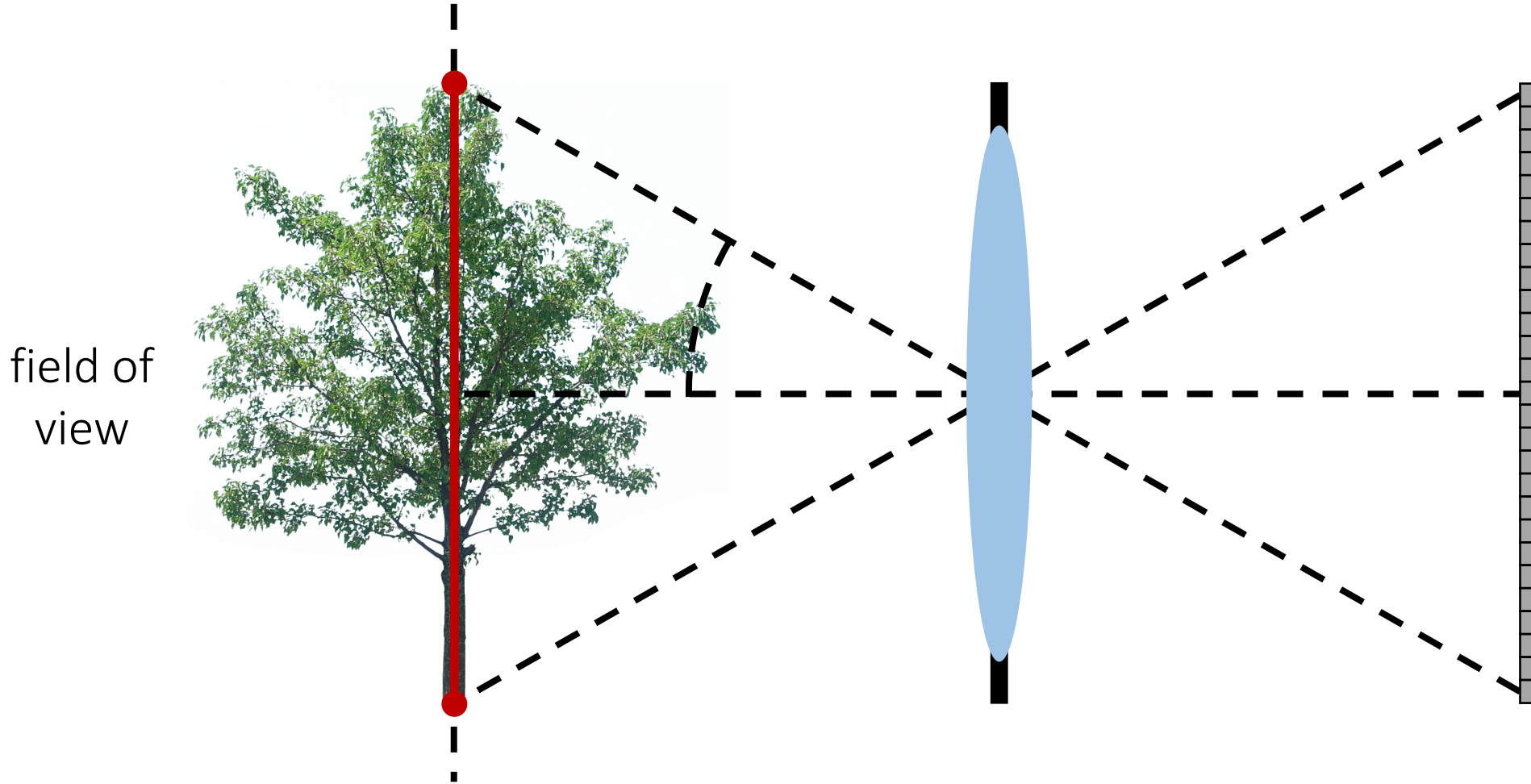

- What happens to field of view as we focus closer?

Field of view

The part of the in-focus plane that gets mapped on the sensor.

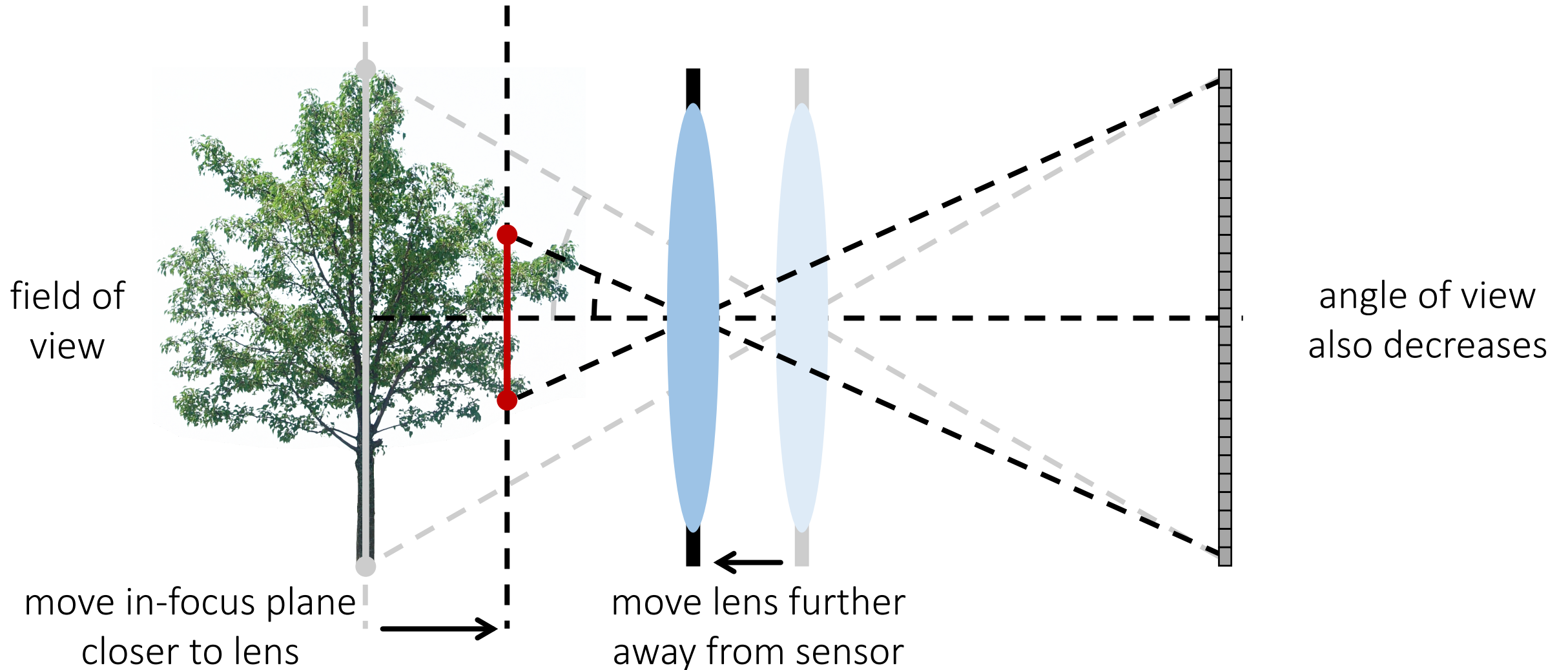

- What happens to field of view as we focus closer? → It becomes smaller.

Comparison with pinhole camera

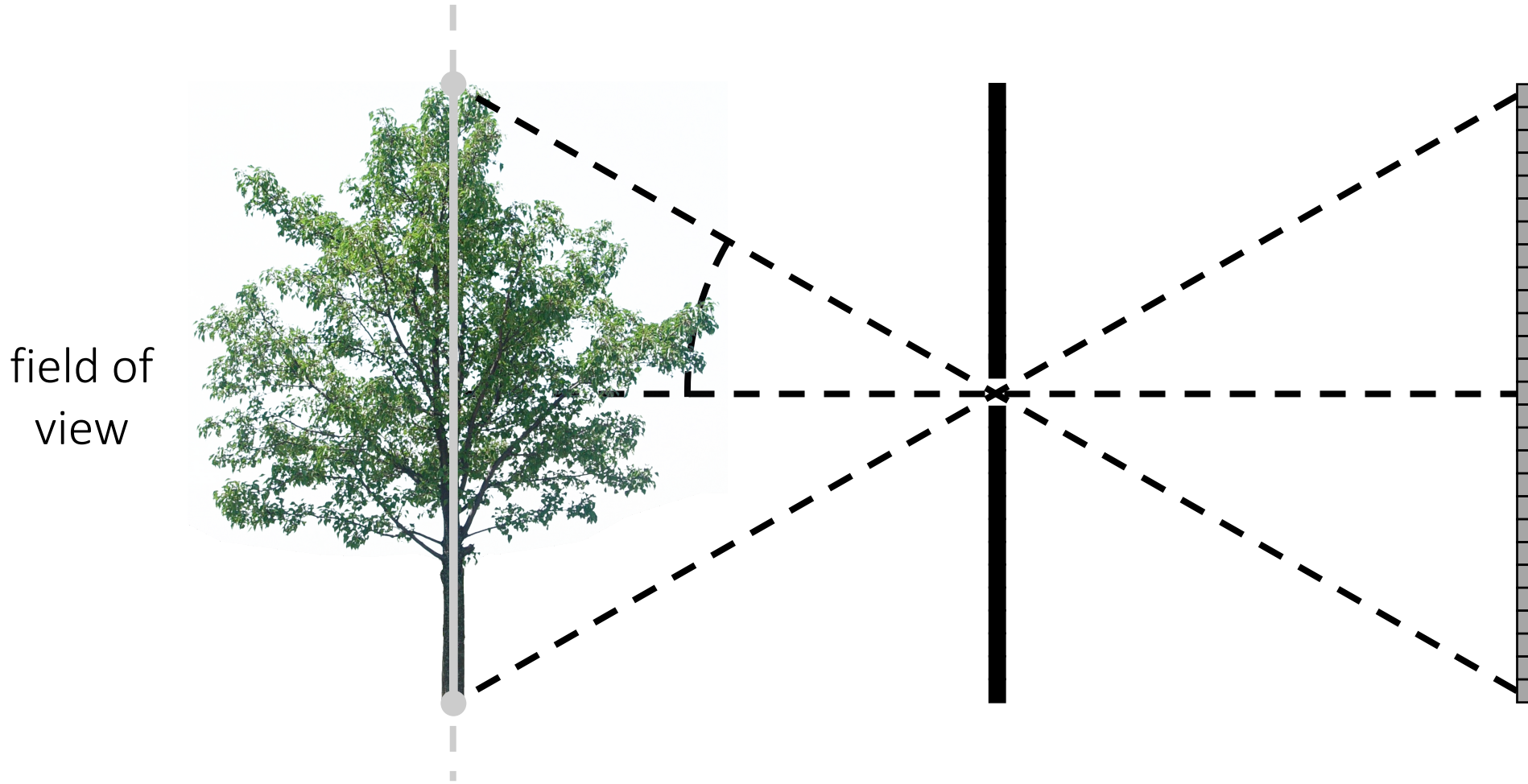

- What happens to field of view as we move closer?

Comparison with pinhole camera

No need to refocus: we can move object closer without changing aperture-sensor distance.

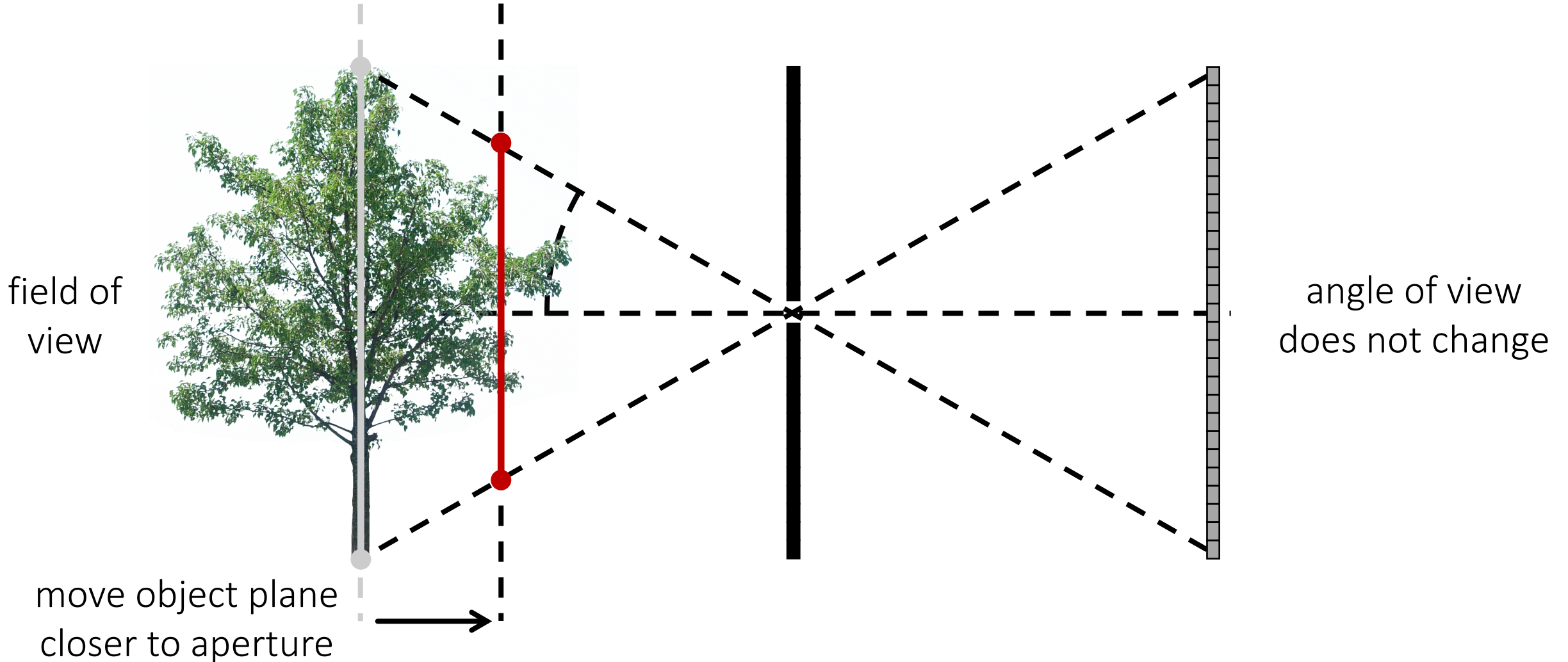

- What happens to field of view as we move closer? → It becomes smaller, but amount differs.

Comparison with pinhole camera

No need to refocus: we can move object closer without changing aperture-sensor distance.

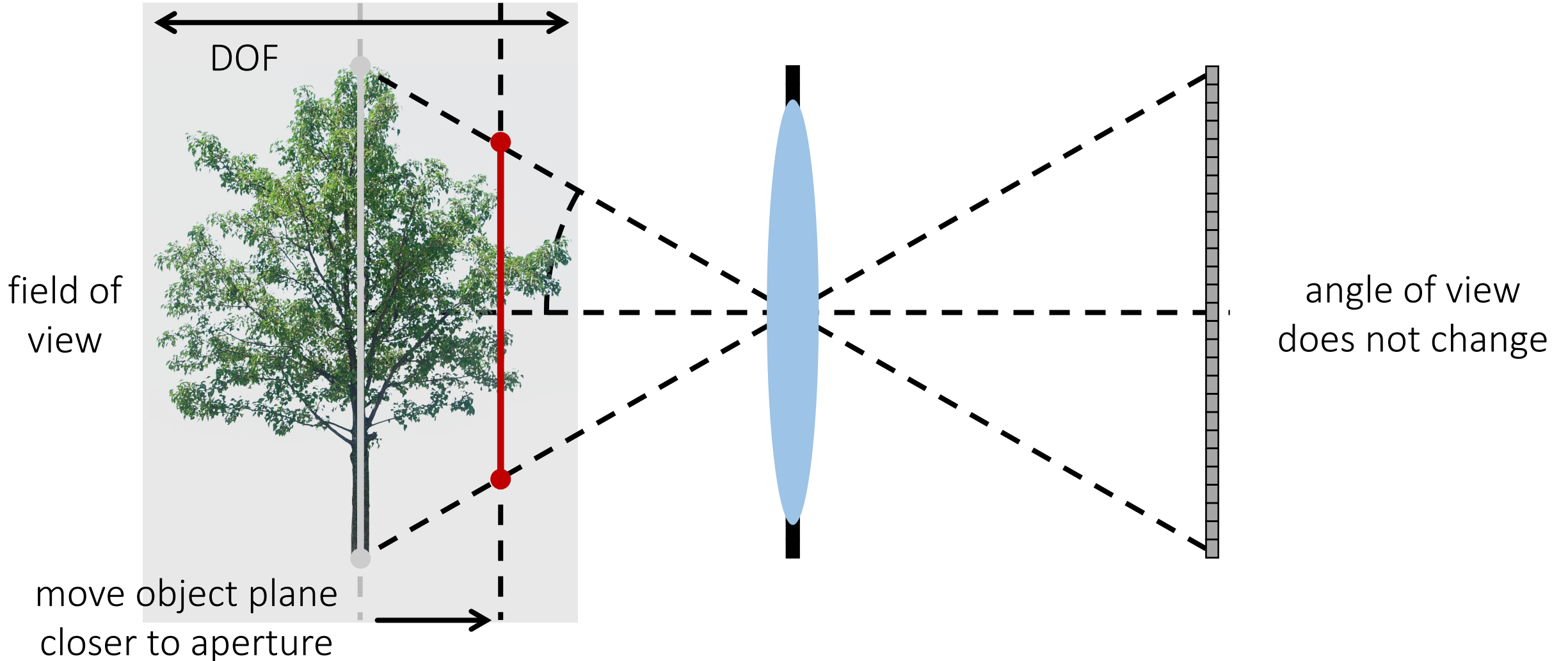

This can be done with a lens *only if* depth of field is large enough. Then the two behave the same.

Field of view also depends on sensor size

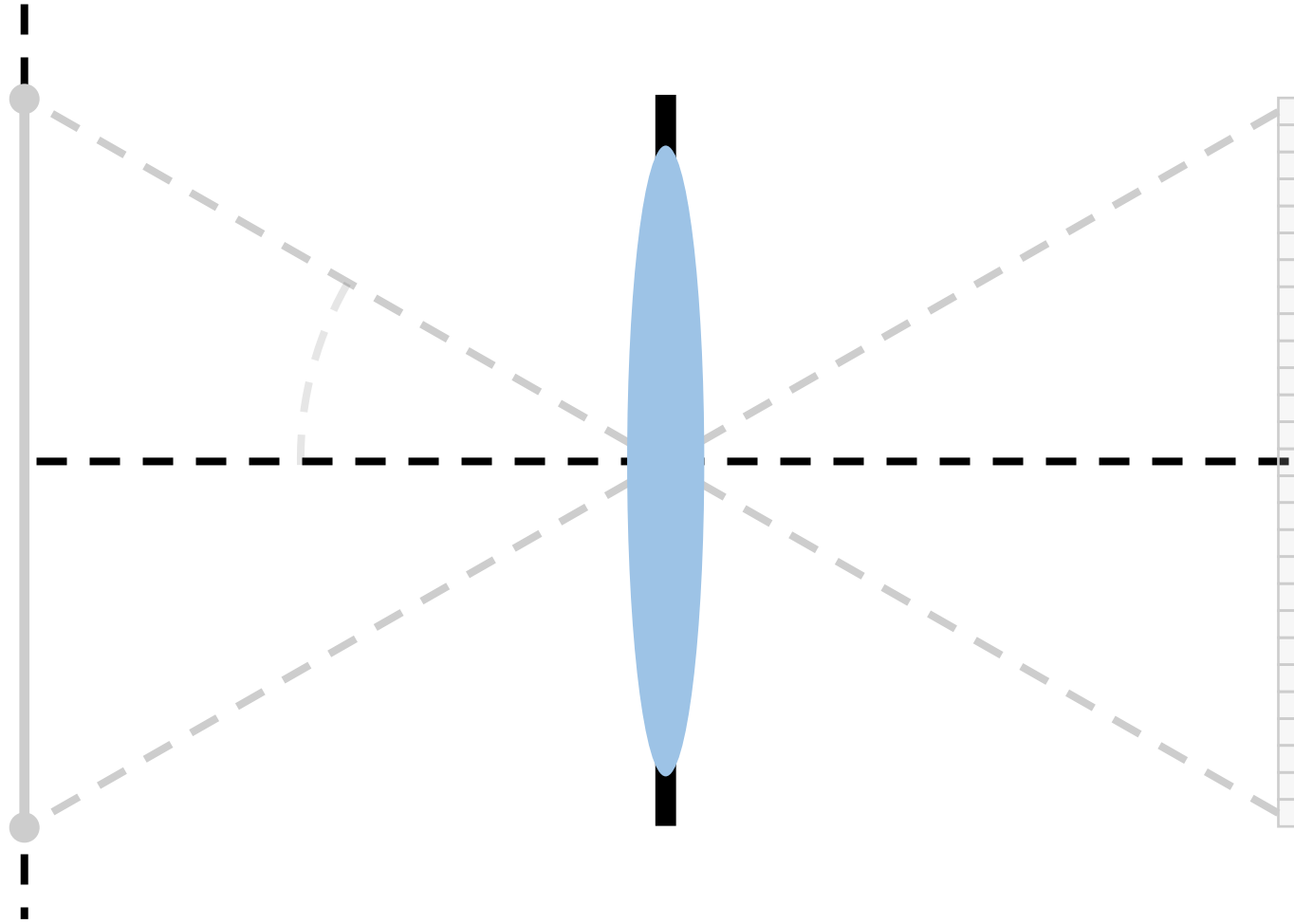

- What happens to field of view when we reduce sensor size?

Field of view also depends on sensor size

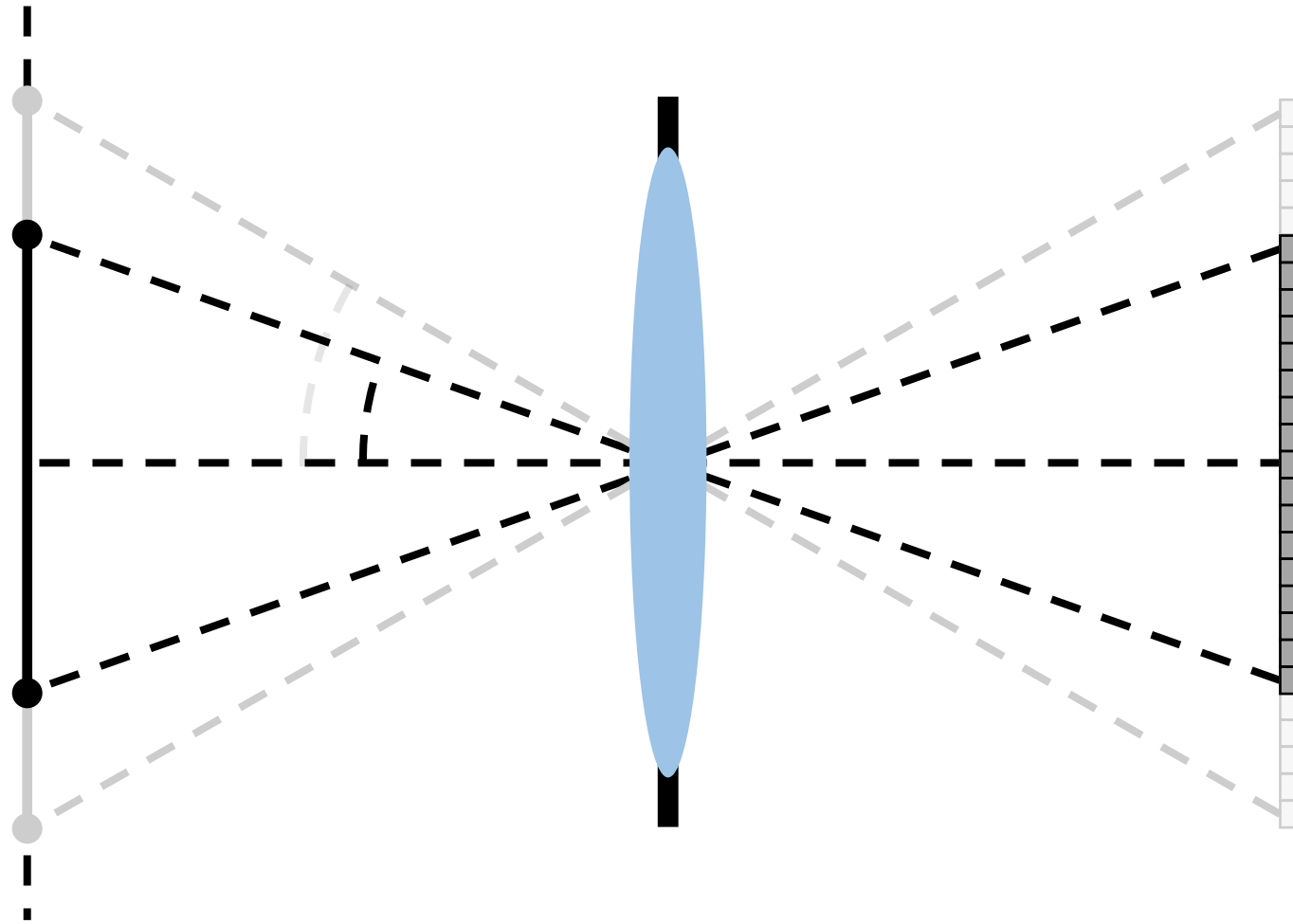

Lens and pinhole cameras behave the same in this case.

- What happens to field of view when we reduce sensor size? → It decreases.

Field of view also depends on sensor size

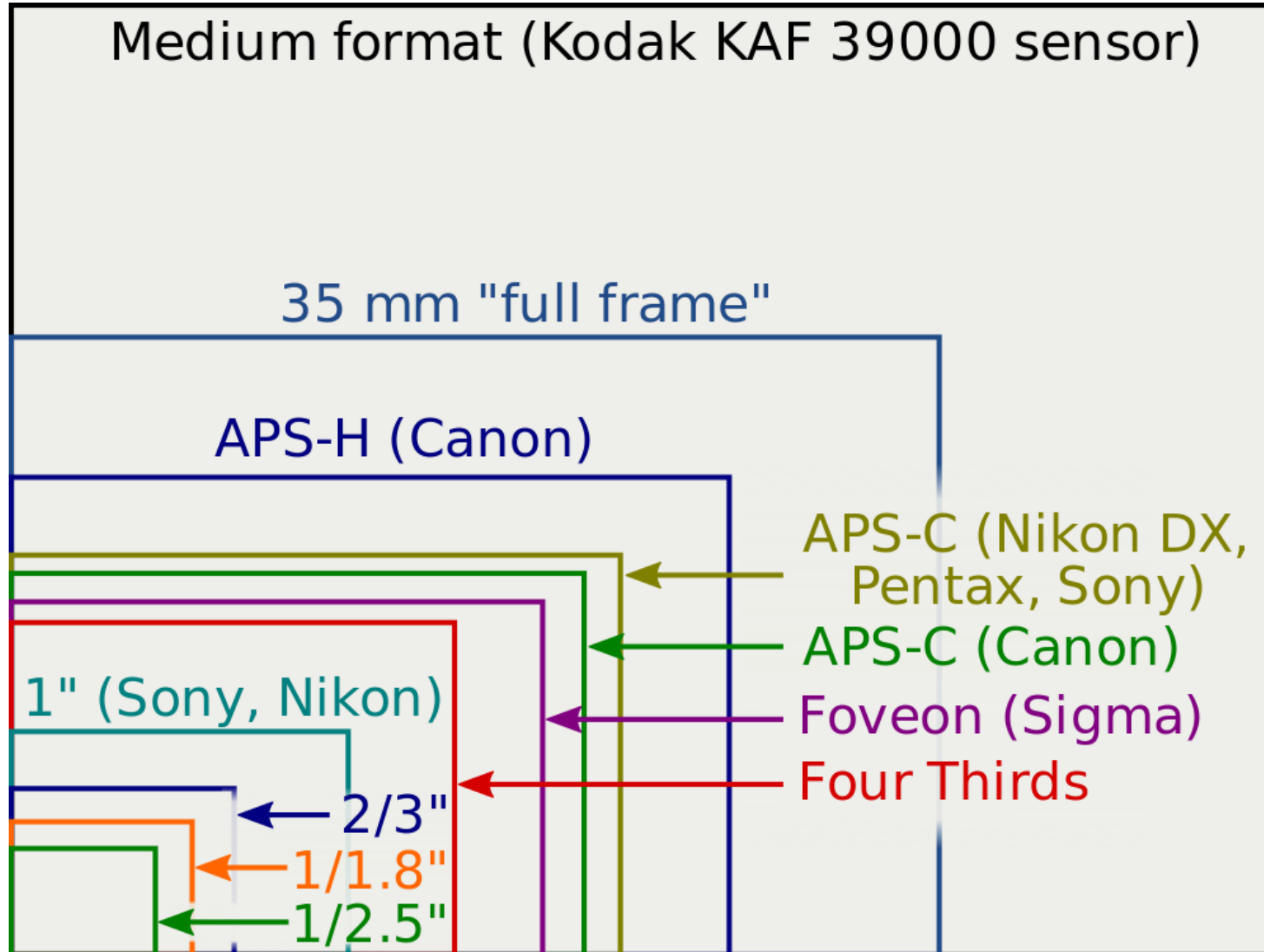

- “Full frame” corresponds to standard film size.
- Digital sensors come in smaller formats due to manufacturing limitations (now mostly overcome).
- Lenses are often described in terms of field of view on film instead of focal length.
- These descriptions are invalid when not using full-frame sensor.

Crop factor

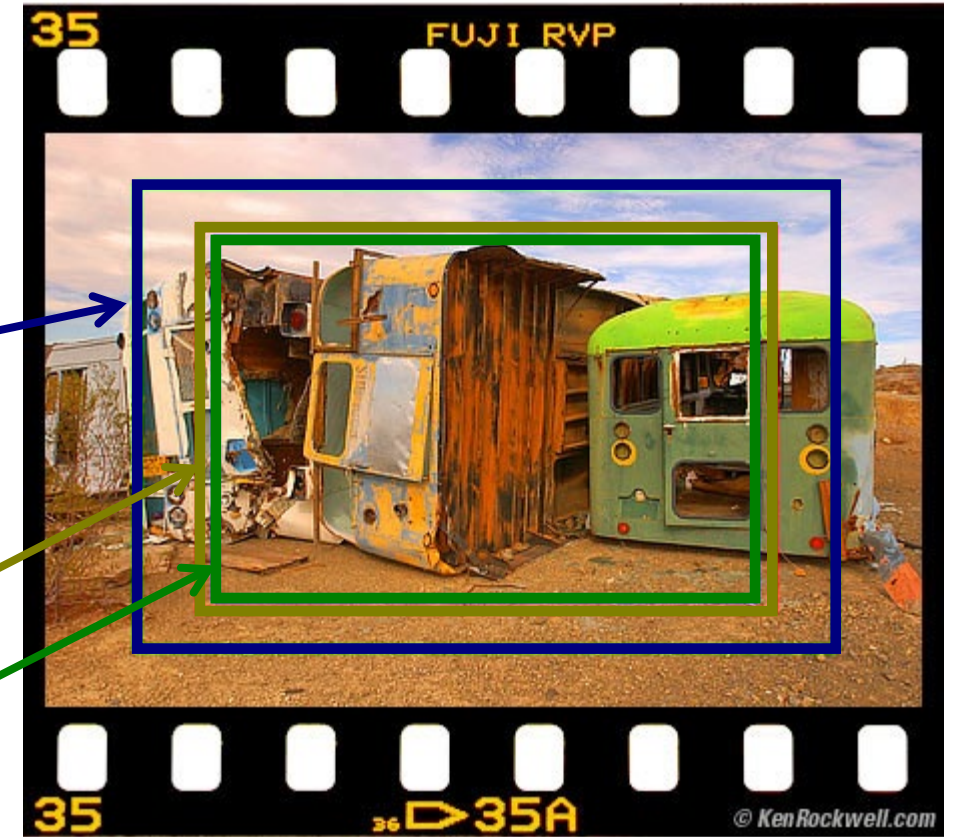
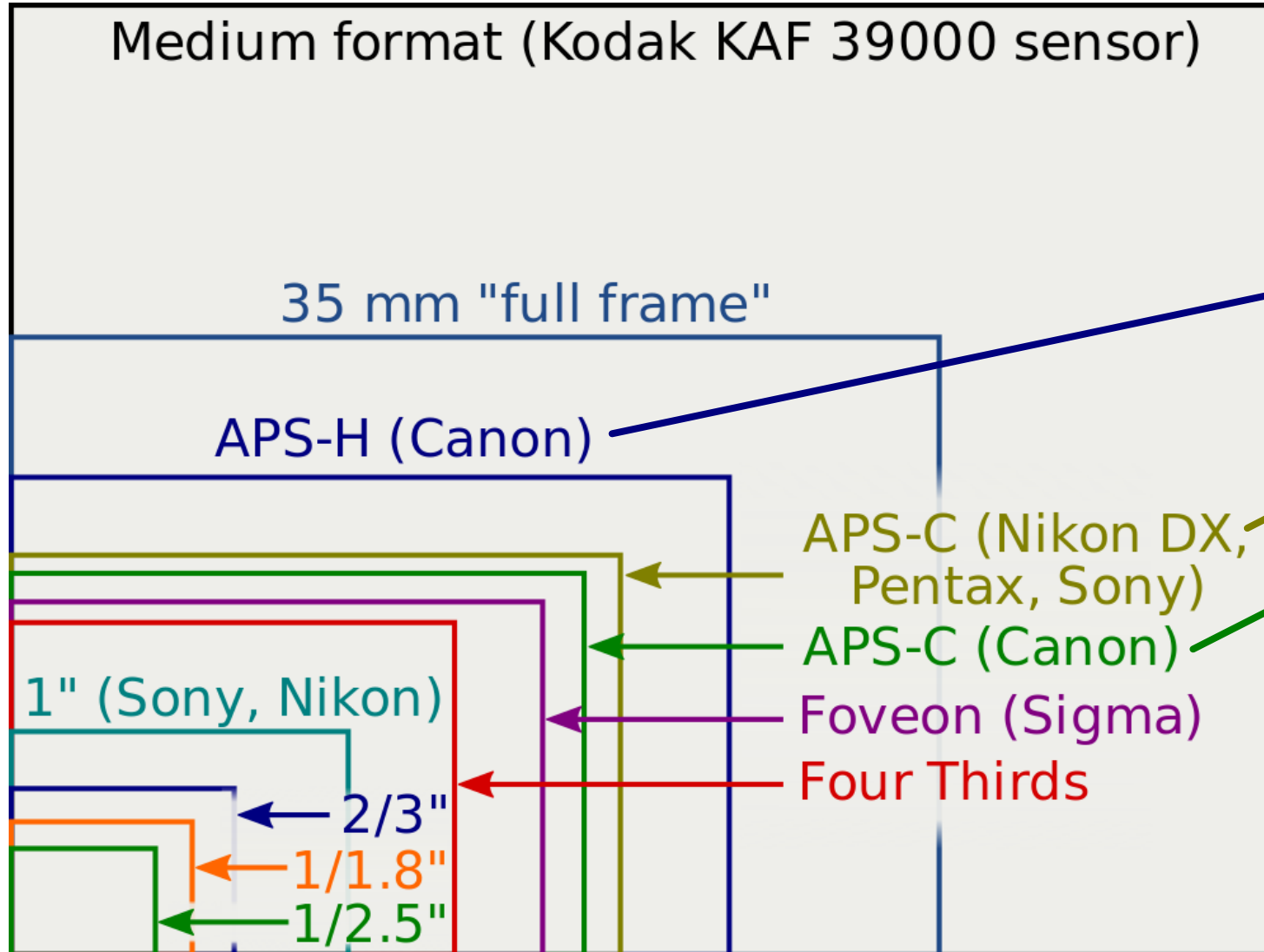

How much field of view is cropped when using a sensor smaller than full frame.

Magnification and perspective

Magnification depends on depth

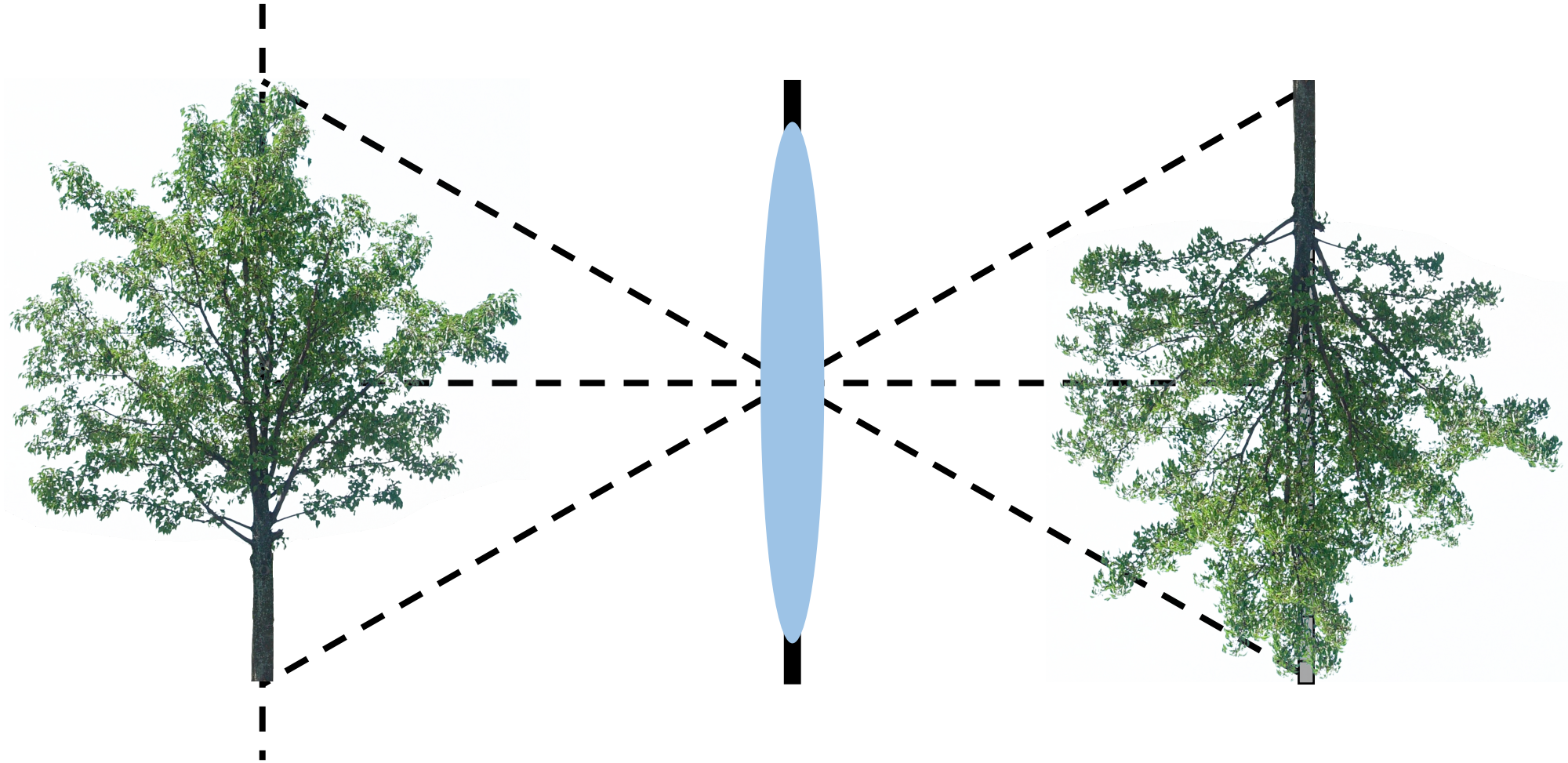

- What happens to magnification as we focus further away?

Magnification depends on depth

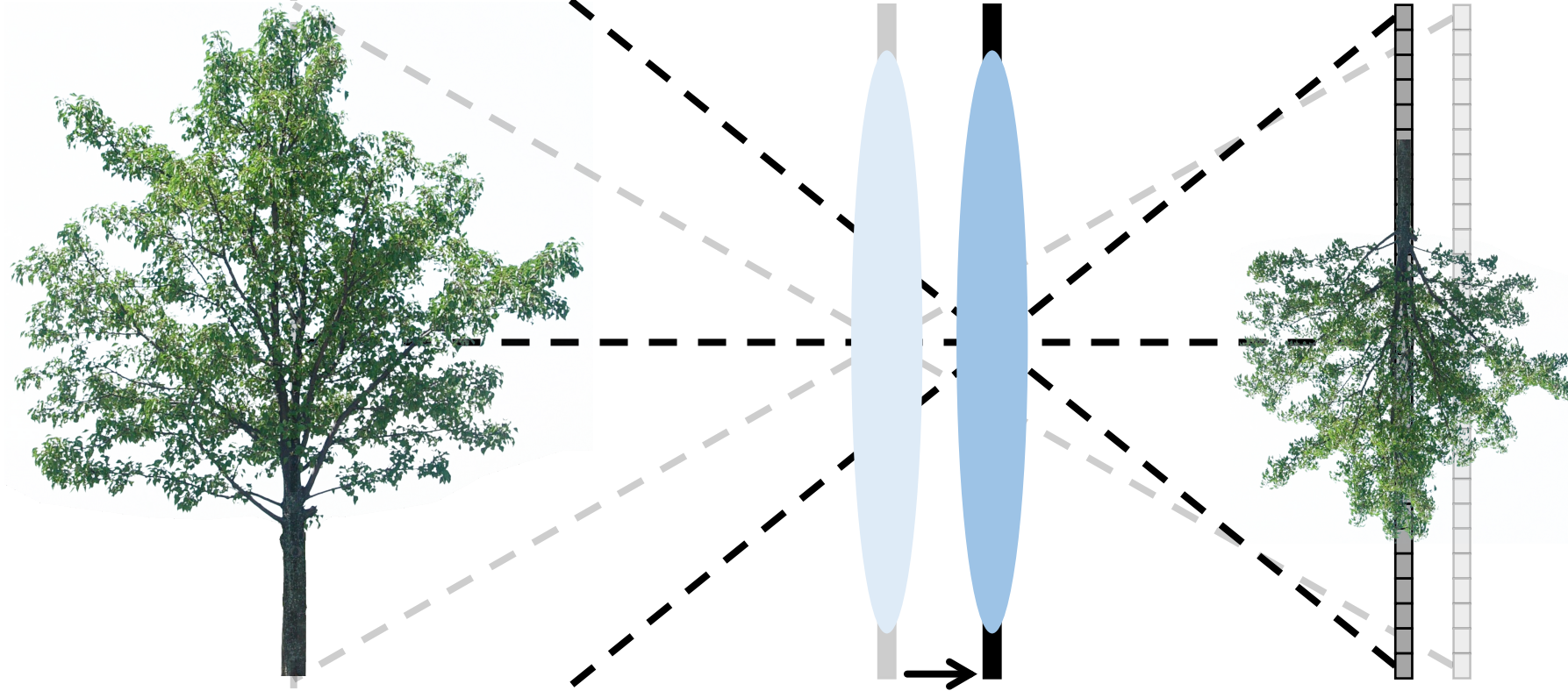

move object further
away from lens

move lens closer
to sensor

- What happens to magnification as we focus further? → It becomes smaller.

Magnification depends on depth

$$\frac{1}{S'} + \frac{1}{S} = \frac{1}{f}$$

$$m = \frac{S' - f}{f}$$

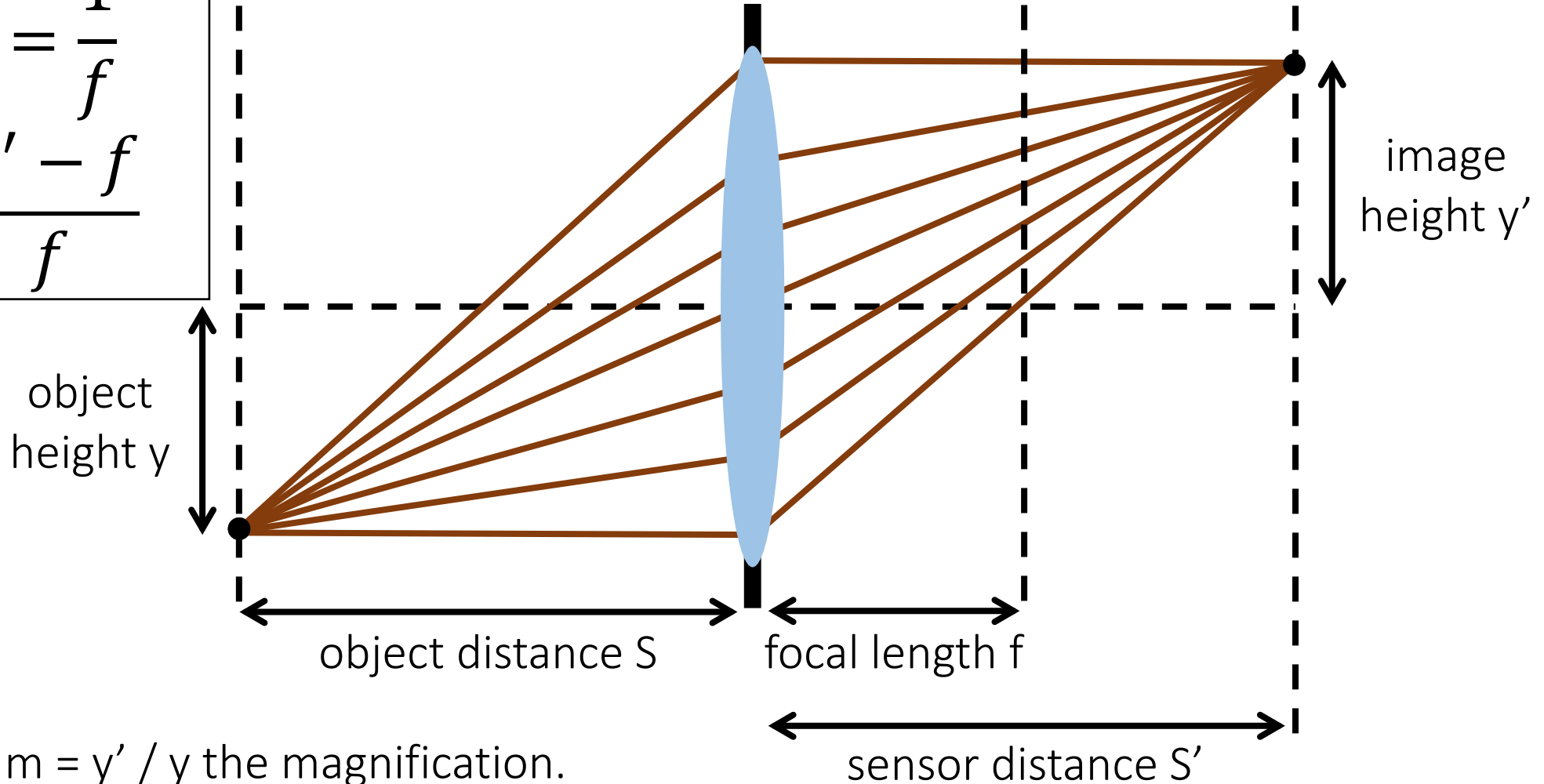

- We call $m = y' / y$ the magnification.

Comparison with pinhole camera

No need to refocus: we can move object further without changing aperture-sensor distance.

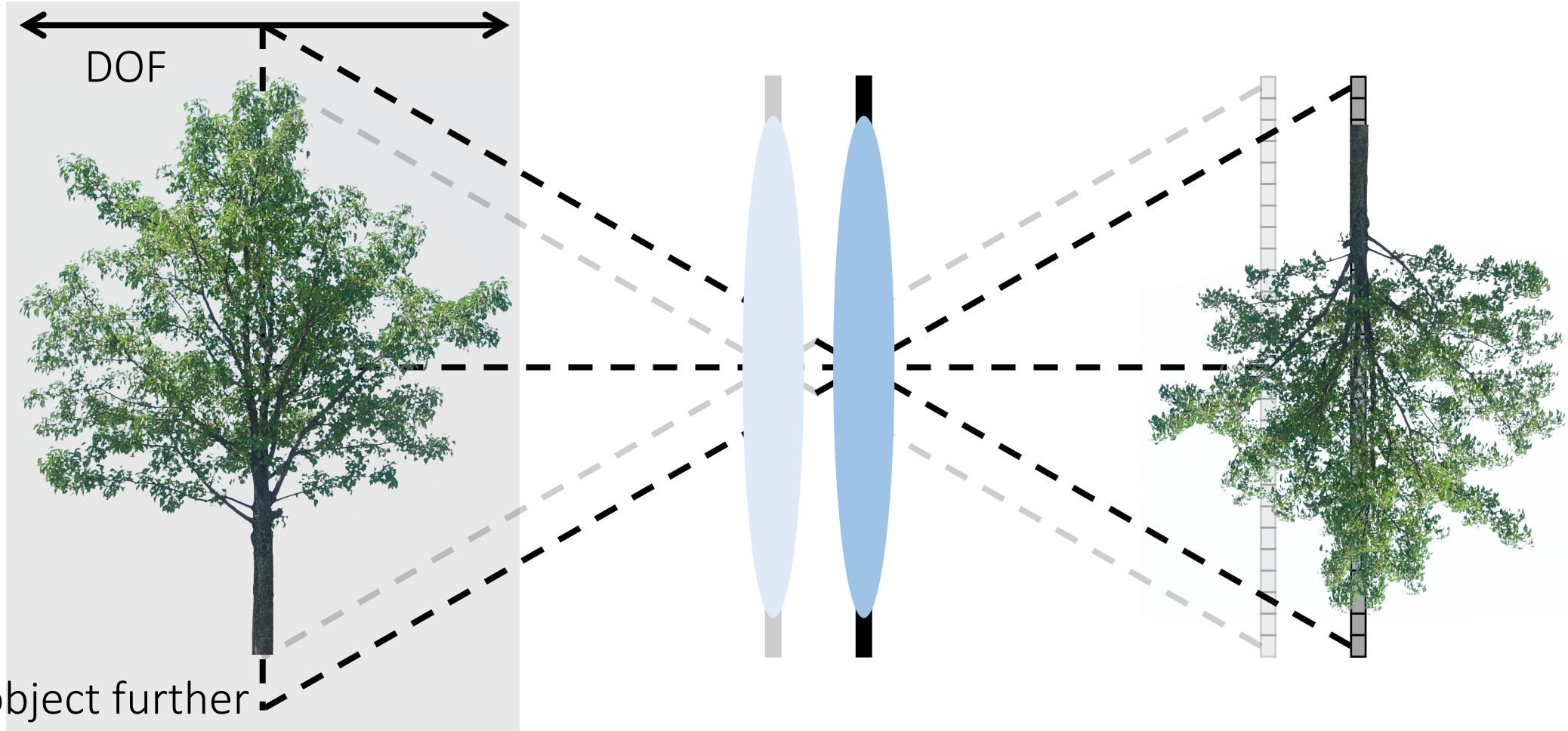

move object further
away from aperture

This can be done with a lens *only if* depth of field is large enough. Then the two behave the same.

Forced perspective



The Ames room illusion



The Ames room illusion

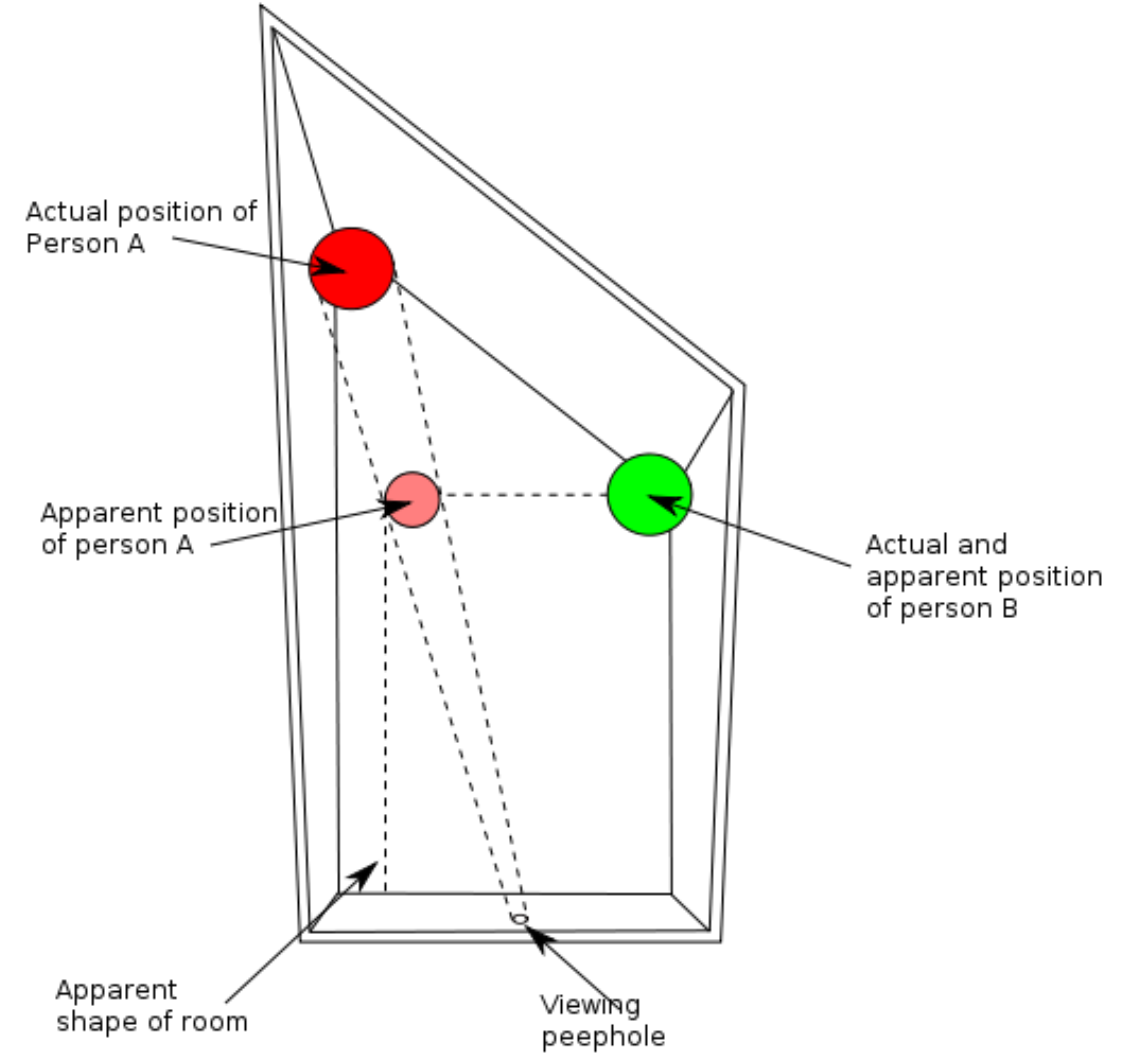
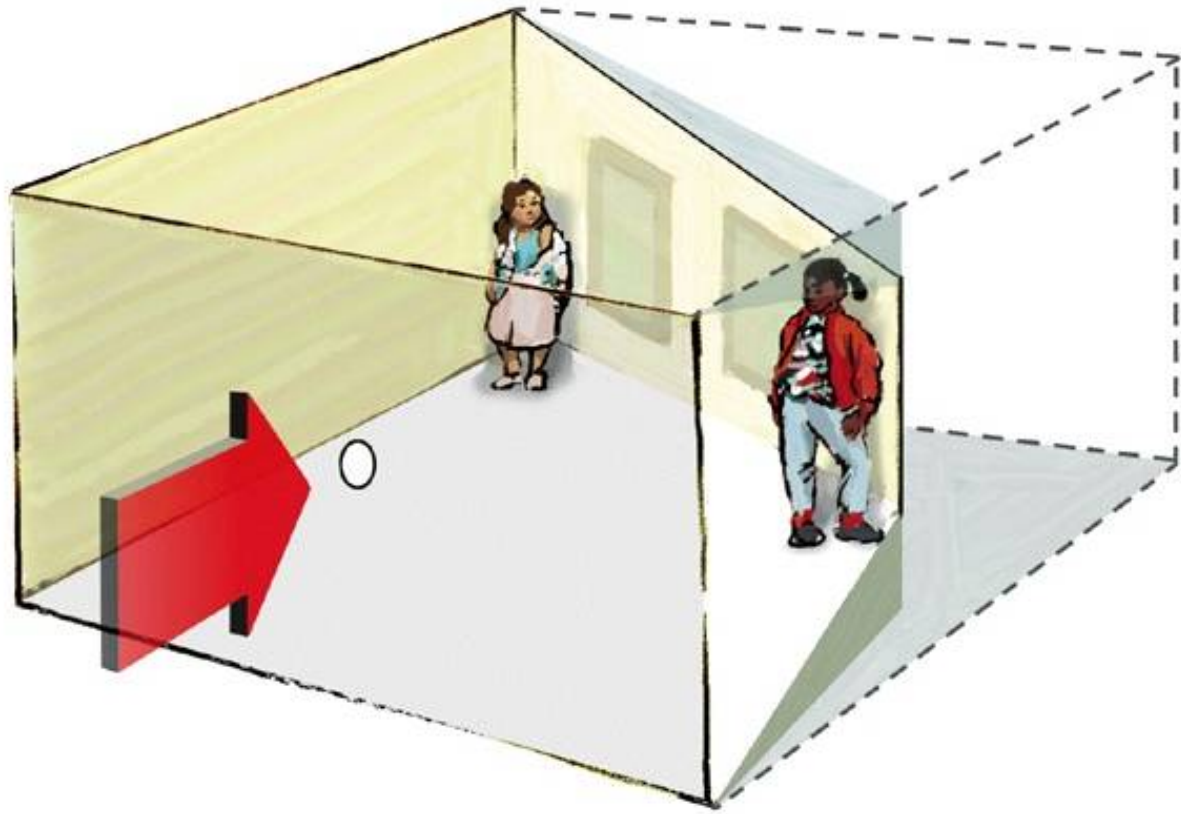

The arrow illusion

Prof. Kokichi Sugihara has many other amazing illusions involving perspective distortion, check them out on YouTube or on his website:

<http://www.isc.meiji.ac.jp/~kokichis/>



Zooming

Field of view

The part of the in-focus plane that gets mapped on the sensor.

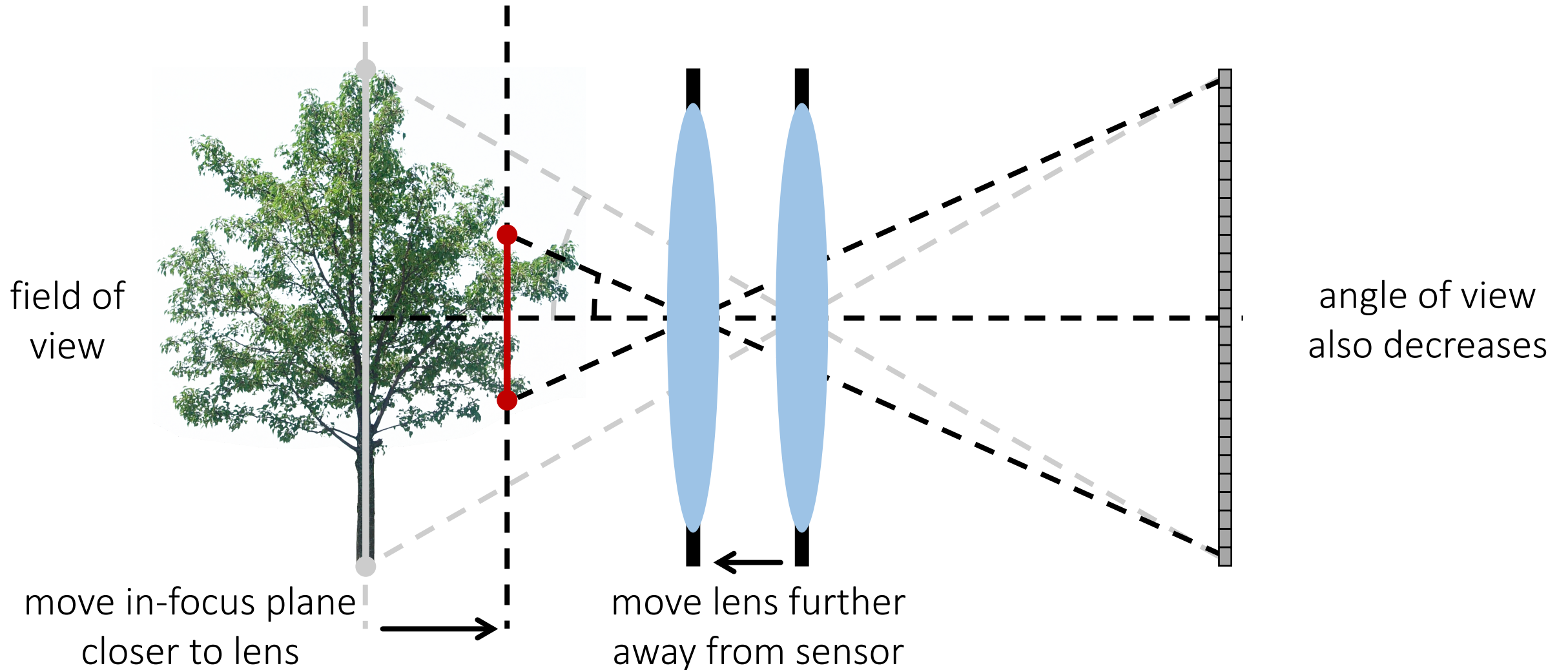

- What happens to field of view as we focus closer? → It becomes smaller.

Zooming means changing the focal length

Very different
process from
refocusing

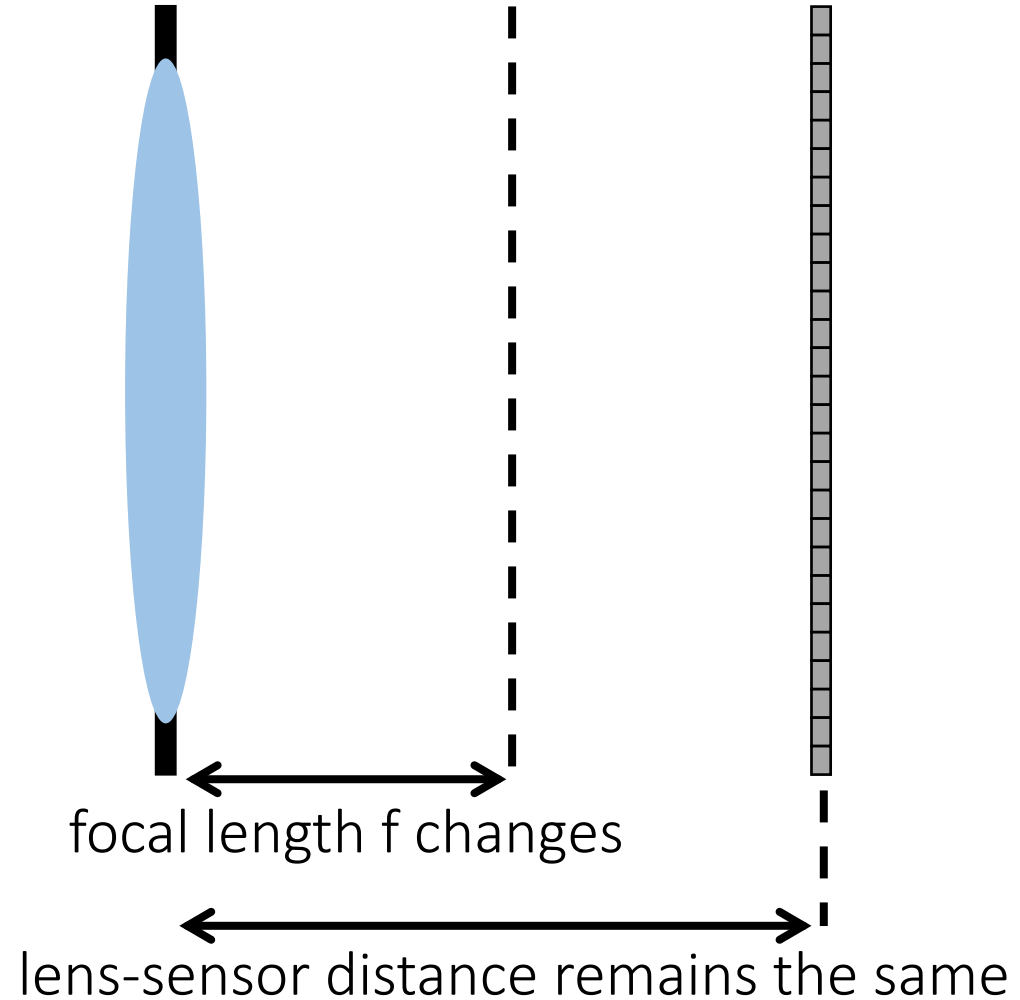

Zooming and field of view

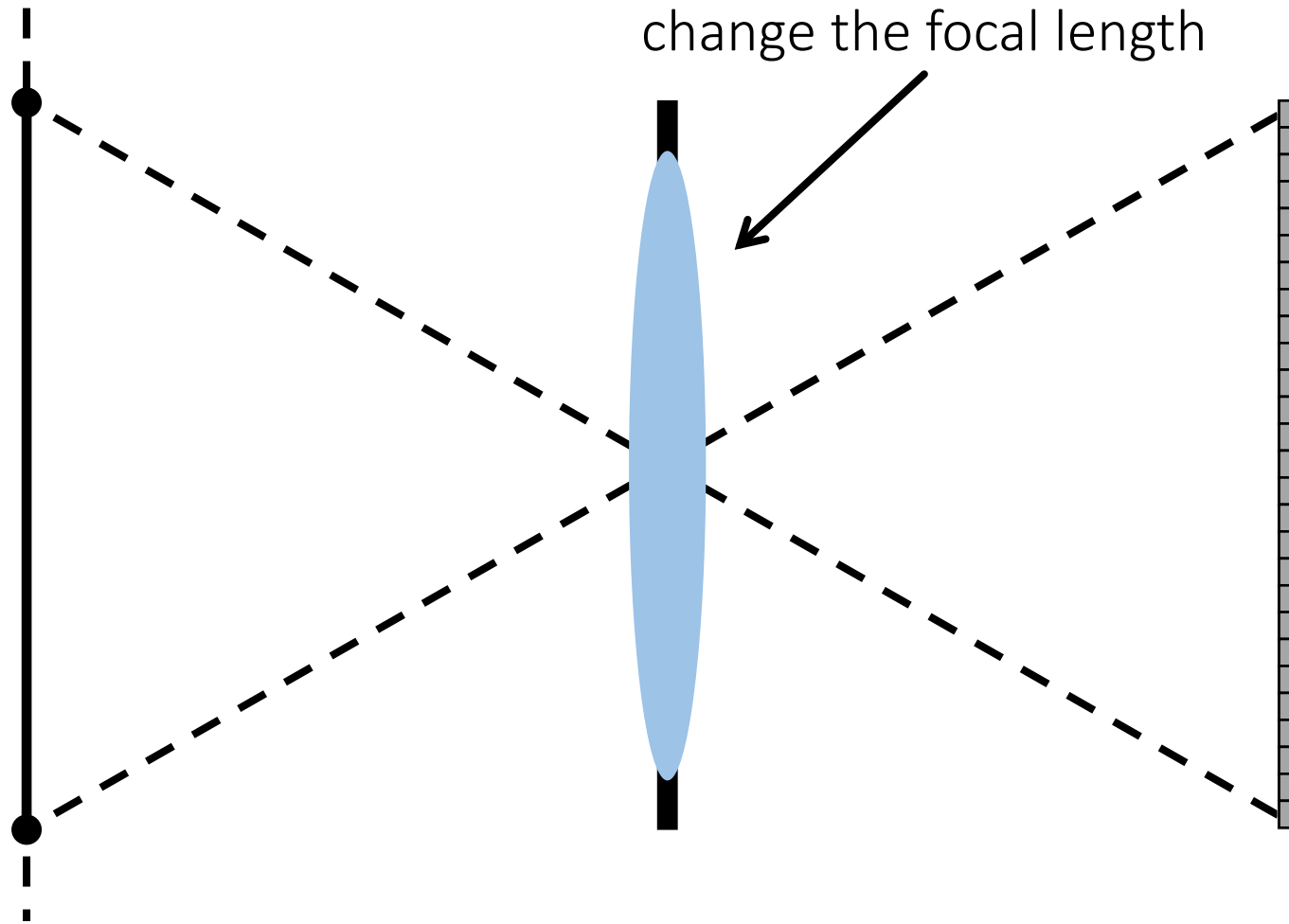

- What happens to field of view when we focus closer? → It decreases.
- What happens to field of view when we increase lens focal length?

Zooming and field of view

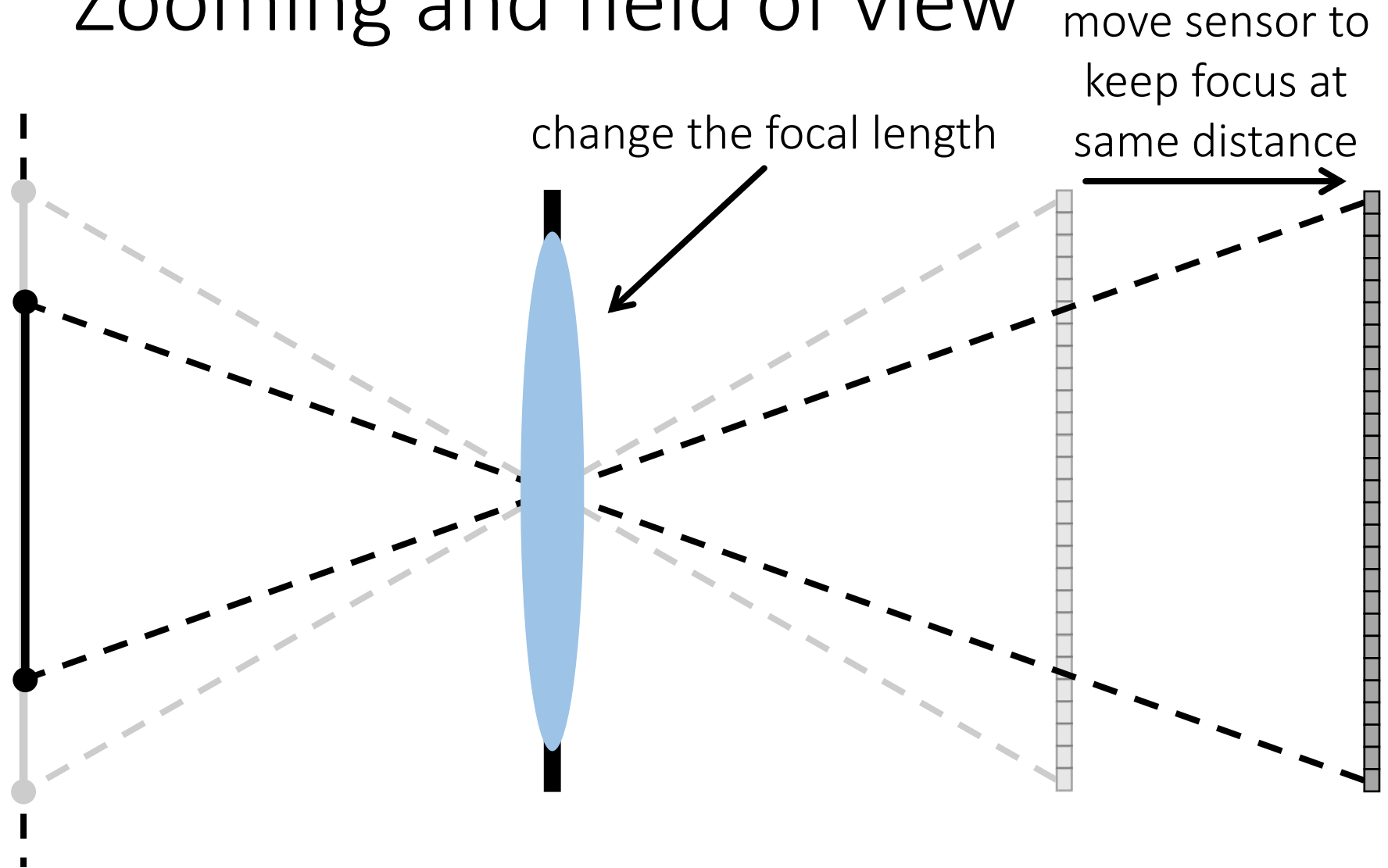

- When we increase lens focal length, field of view decreases (we “zoom in”).

Field of view

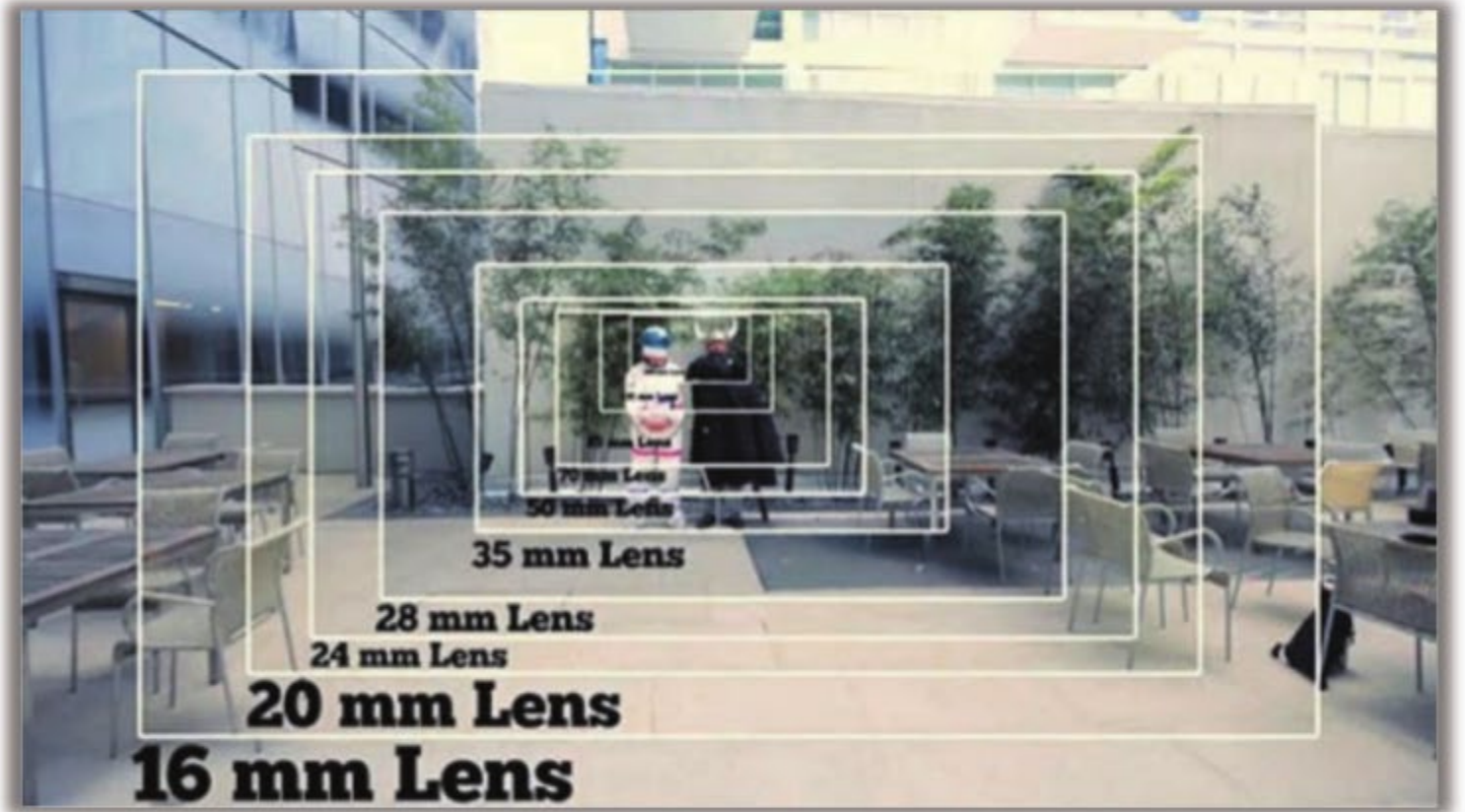
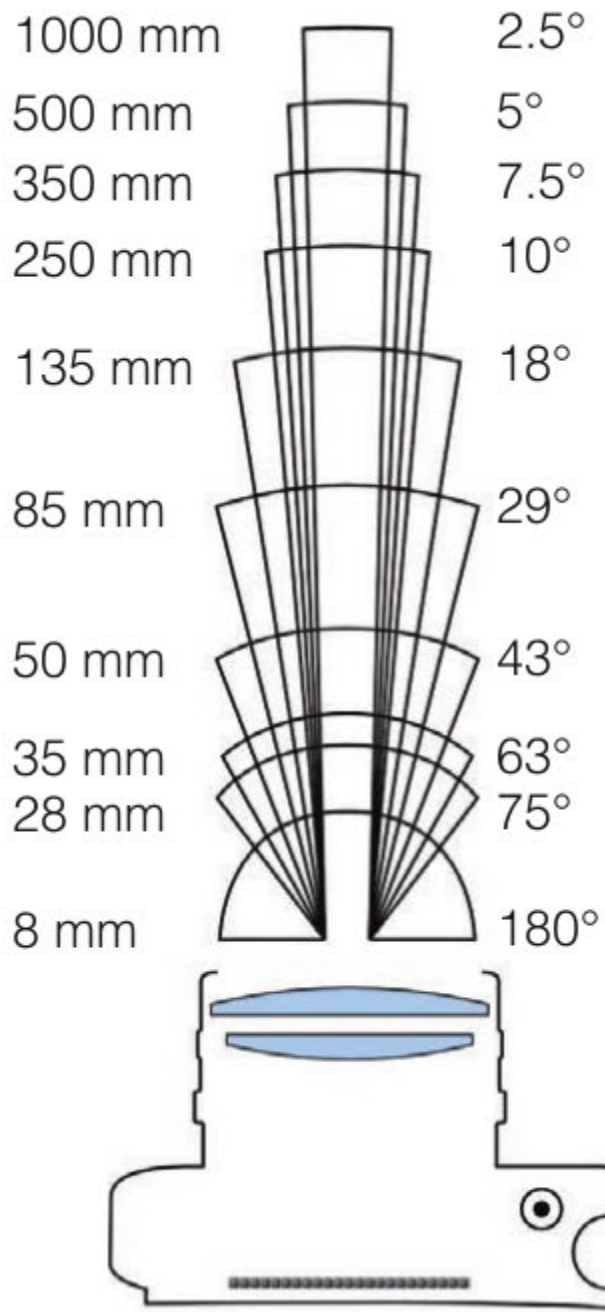

Andrew McWilliams

Field of view

Increasing the lens focal length is similar to cropping

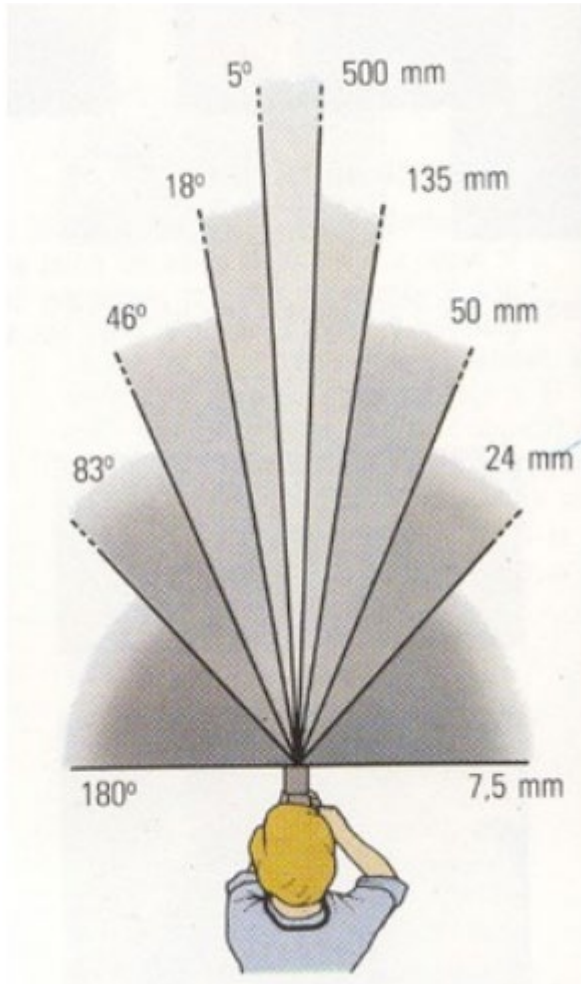

$f = 25 \text{ mm}$



$f = 50 \text{ mm}$

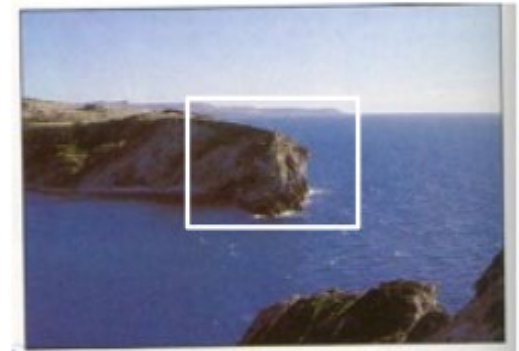

$f = 135 \text{ mm}$



Is this effect identical to cropping?

The lens on your camera

Focus ring: controls distance of lens from sensor



Zoom ring: controls focal length of lens

Focusing versus zooming

When you turn the focus ring to bring lens further-away from the sensor:

1. The in-focus distance decreases (you need to get closer to object).
2. The field of view decreases (you see a smaller part of the object).
3. The magnification increases (same part of the object is bigger on sensor).

When you turn the zoom ring to decrease the focal length of the lens:

1. The in-focus distance increases (you need to move away from the object).
2. The field of view increases (you see a larger part of the object).
3. The magnification decreases (same part of the object is smaller on sensor).

Focusing versus zooming

When you turn the focus ring to bring lens further-away from the sensor:

1. The in-focus distance decreases (you need to get closer to object).
2. The field of view decreases (you see a smaller part of the object).
3. The magnification increases (same part of the object is bigger on sensor).

When you turn the zoom ring to decrease the focal length of the lens:

1. The in-focus distance increases (you need to move away from the object).
2. The field of view increases (you see a larger part of the object).
3. The magnification decreases (same part of the object is smaller on sensor).

We can use both focus and zoom to cancel out their effects.

What if...

real-world
object



1. Set focal length to half

depth $2 Z$

focal length $2 f$

focal
length f

What if...

real-world
object

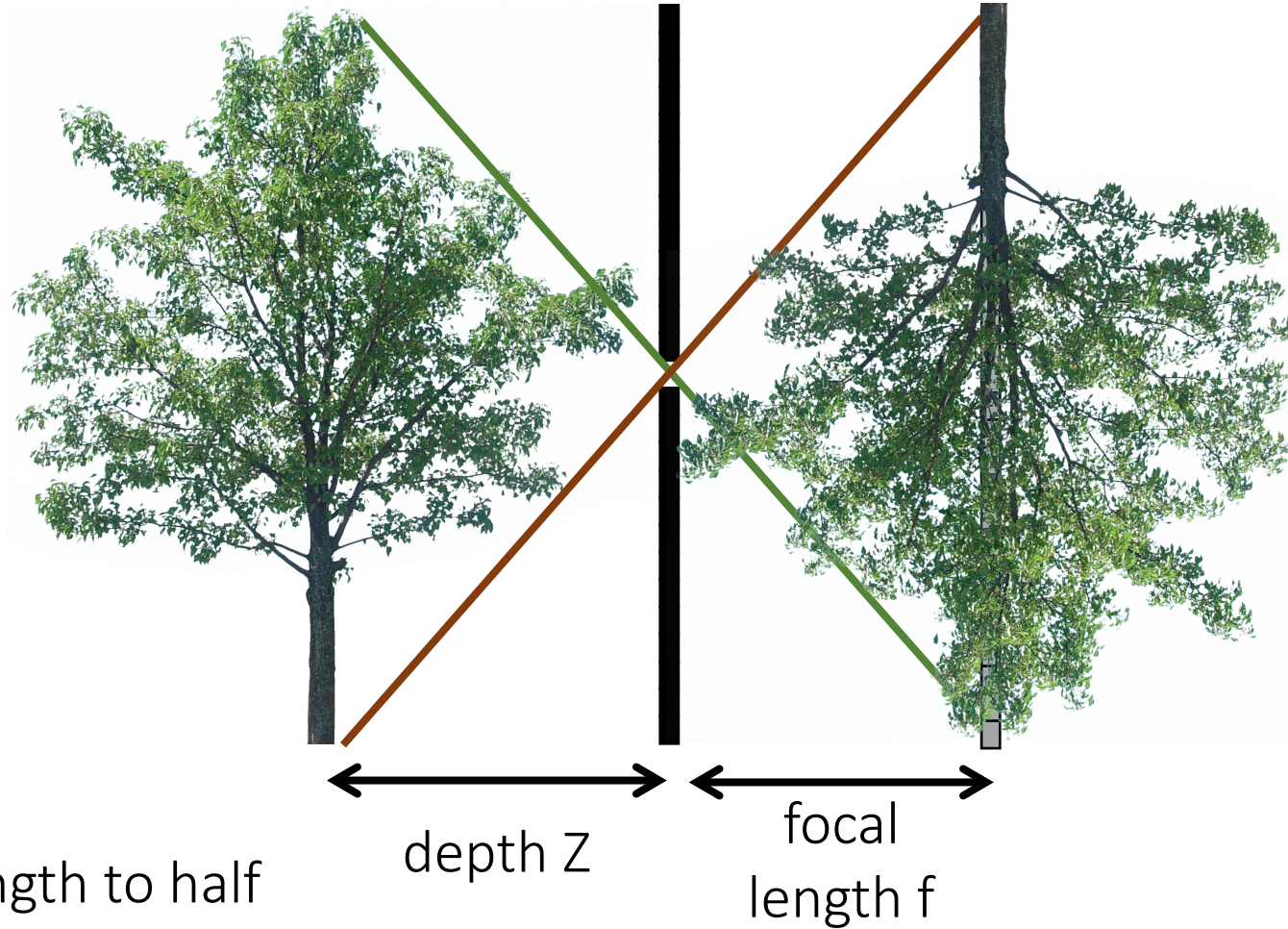

Is this the same image as
the one we had at focal
length $2f$ and distance $2Z$?

Similar construction can
be done with lenses, after
taking care of refocusing.

1. Set focal length to half
2. Set depth to half

Perspective distortion



long focal length



mid focal length



short focal length

Perspective distortion

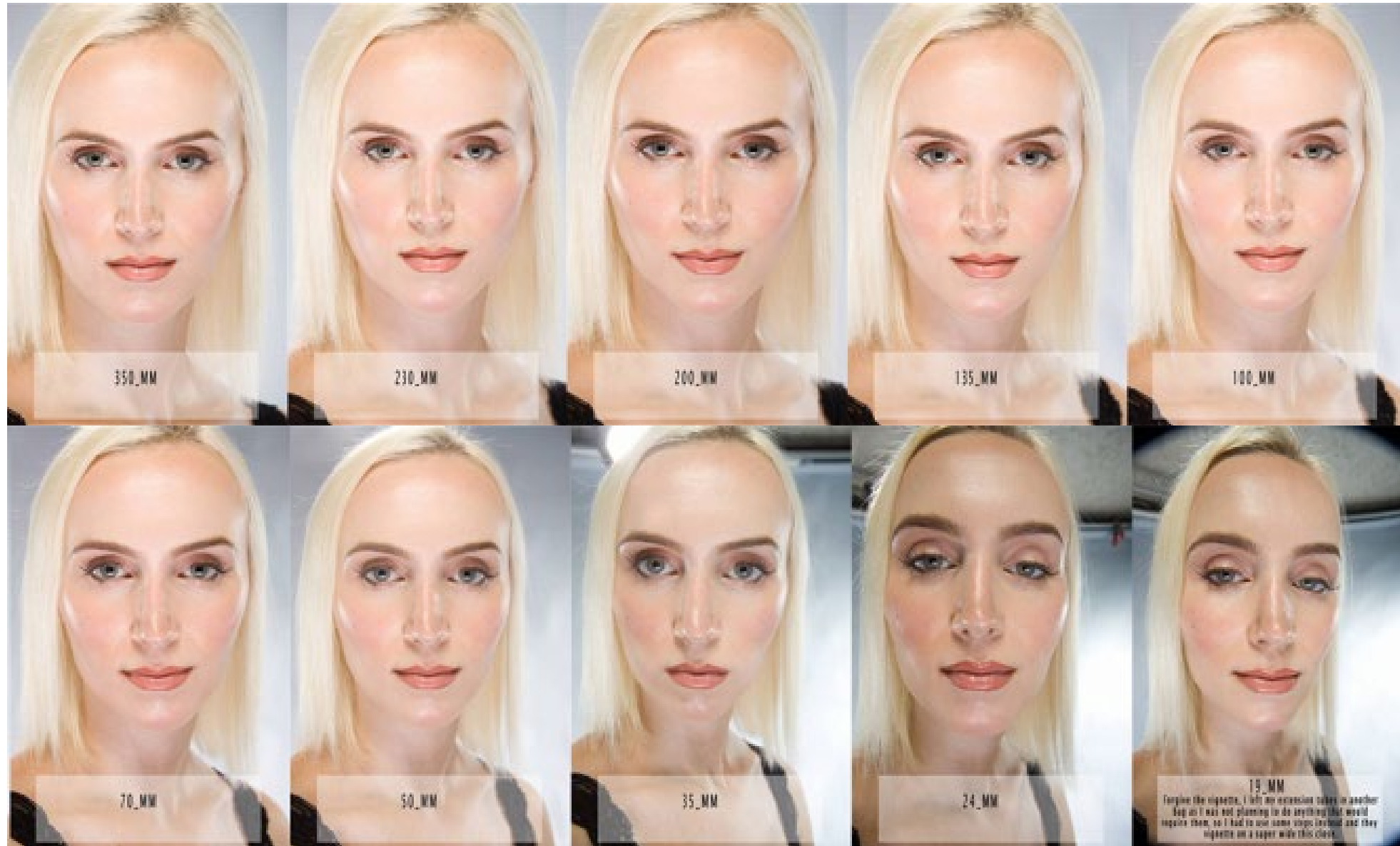

What is the best focal length for portraits?

That's like asking which is better, vi or emacs...



long focal length



mid focal length



short focal length

Vertigo effect

Named after Alfred Hitchcock's movie

- also known as “dolly zoom”



Vertigo effect



How would you
create this effect?

Orthographic camera and telecentric lenses

What if...

real-world
object

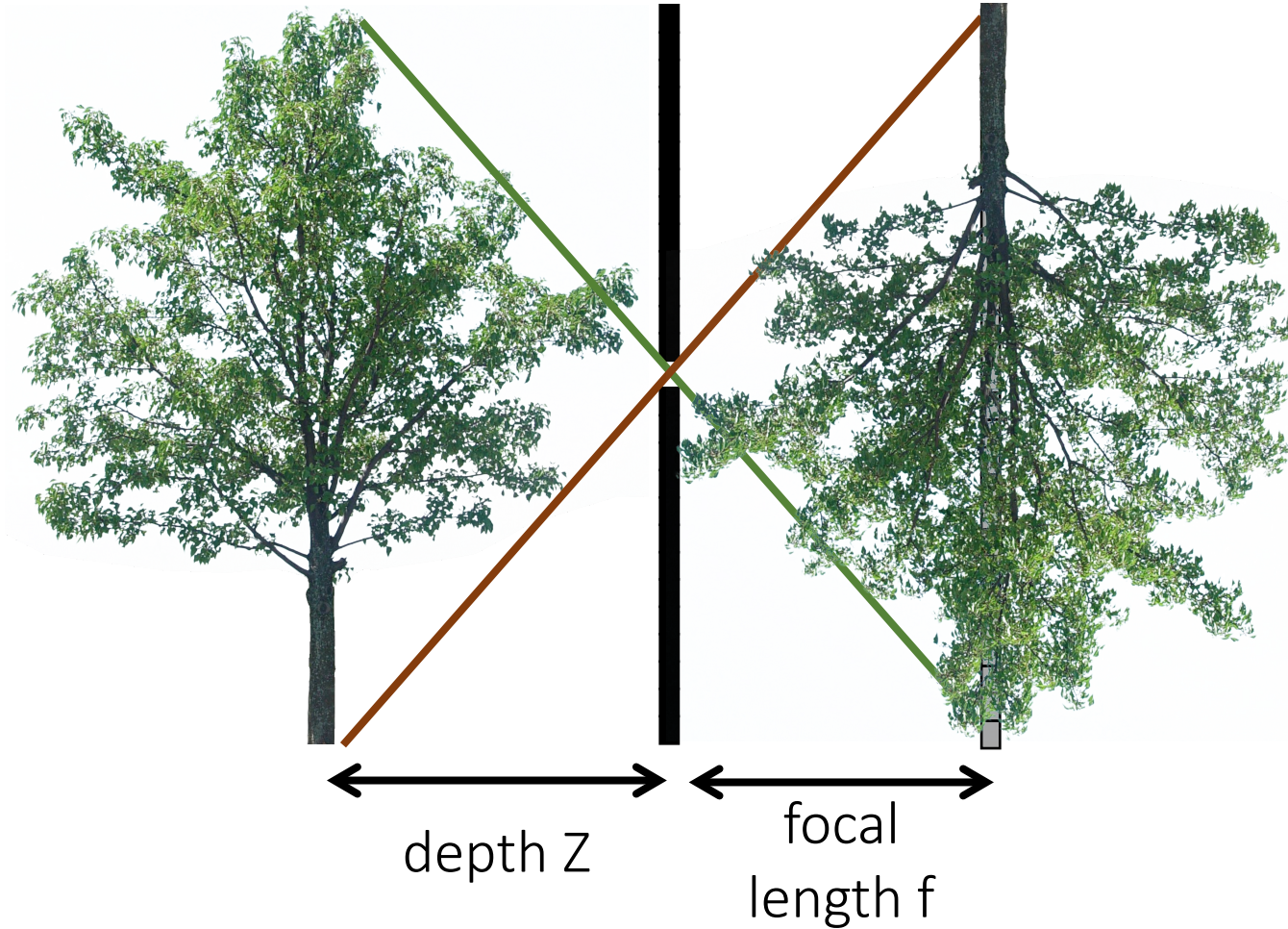

Continue increasing Z and f while maintaining same magnification?

$$f \rightarrow \infty \text{ and } \frac{f}{Z} = \text{constant}$$

Orthographic camera

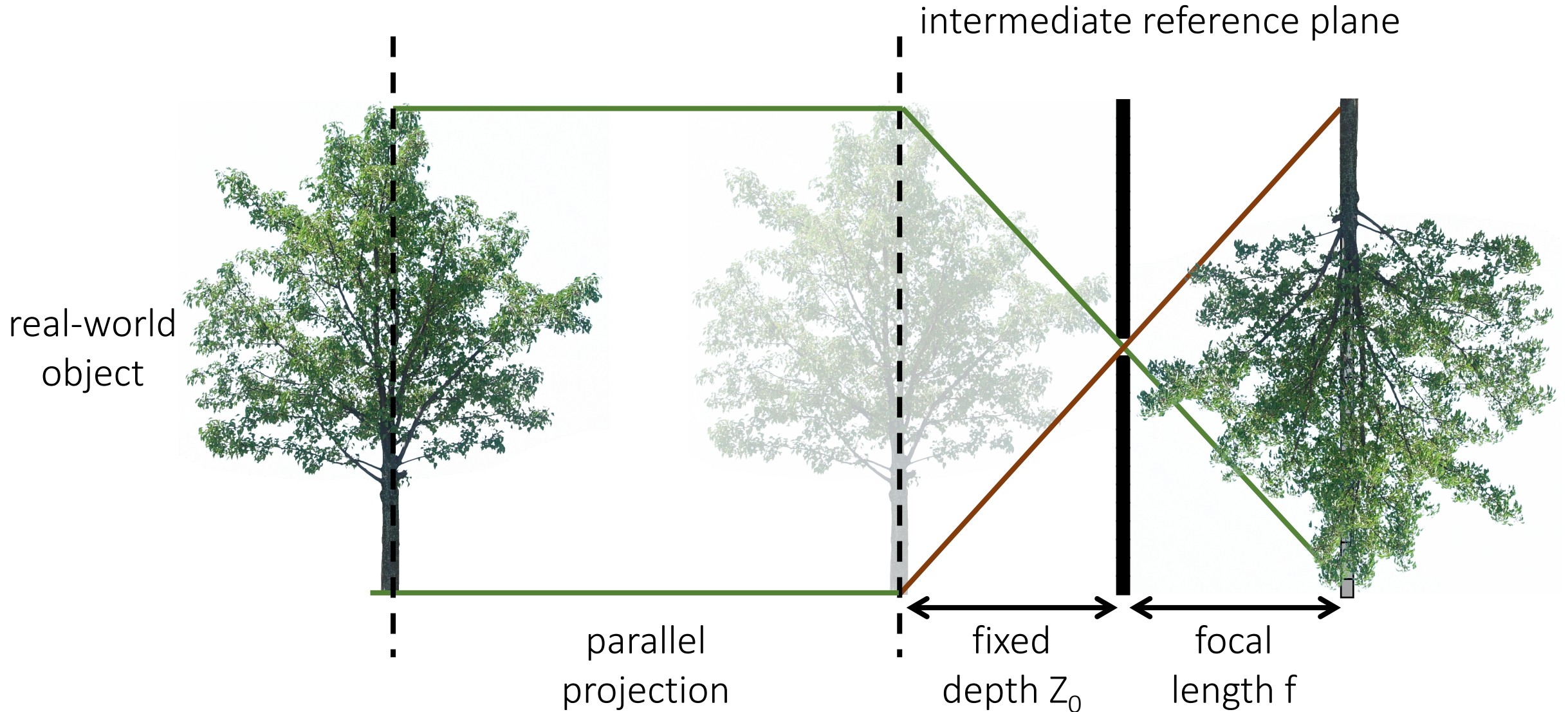

Depth-independent magnification $m = 1$ (real-life size).

Weak-perspective camera

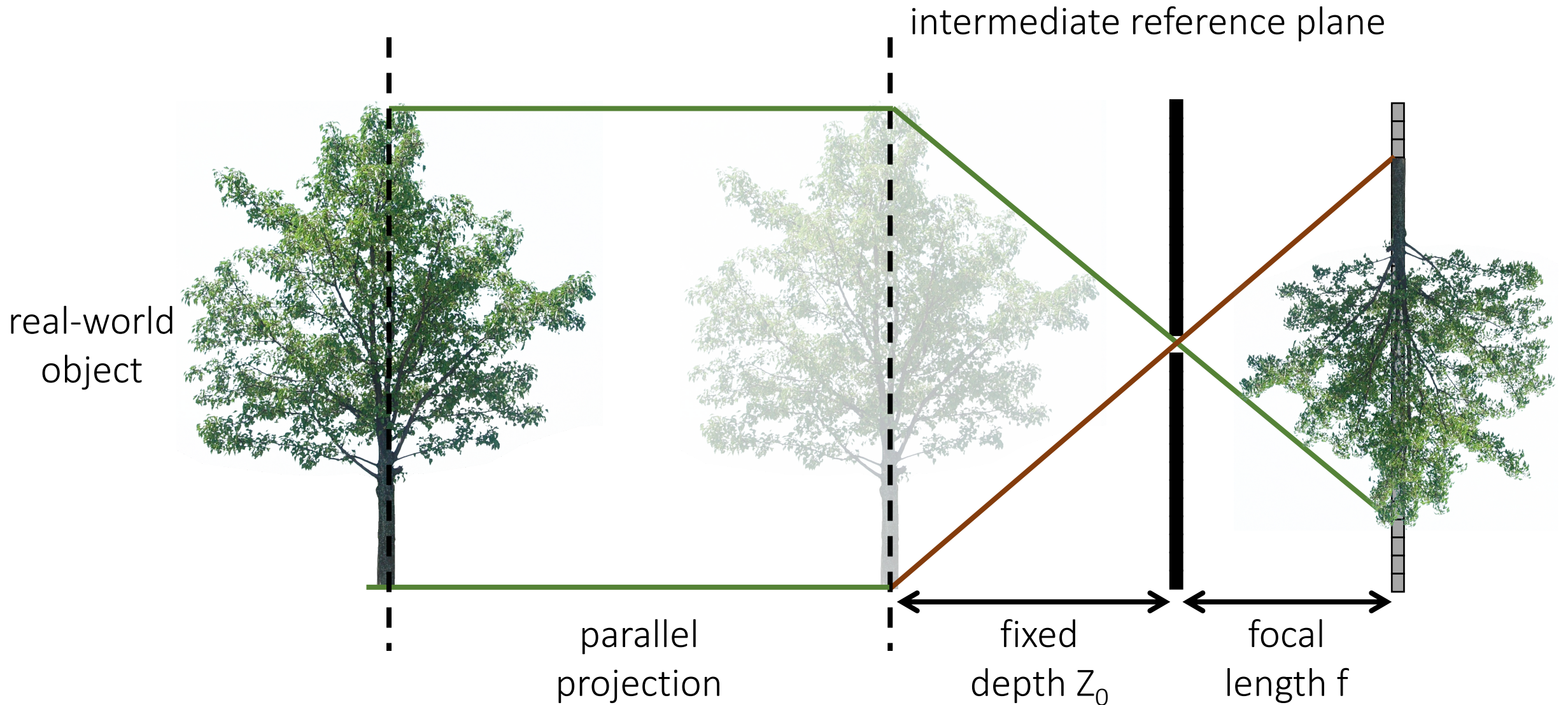

Depth-independent magnification $m = f / Z_0$.

How can we implement such a camera with lenses?

Telecentric lens

Place a pinhole at focal length, so that only rays parallel to primary ray pass through.

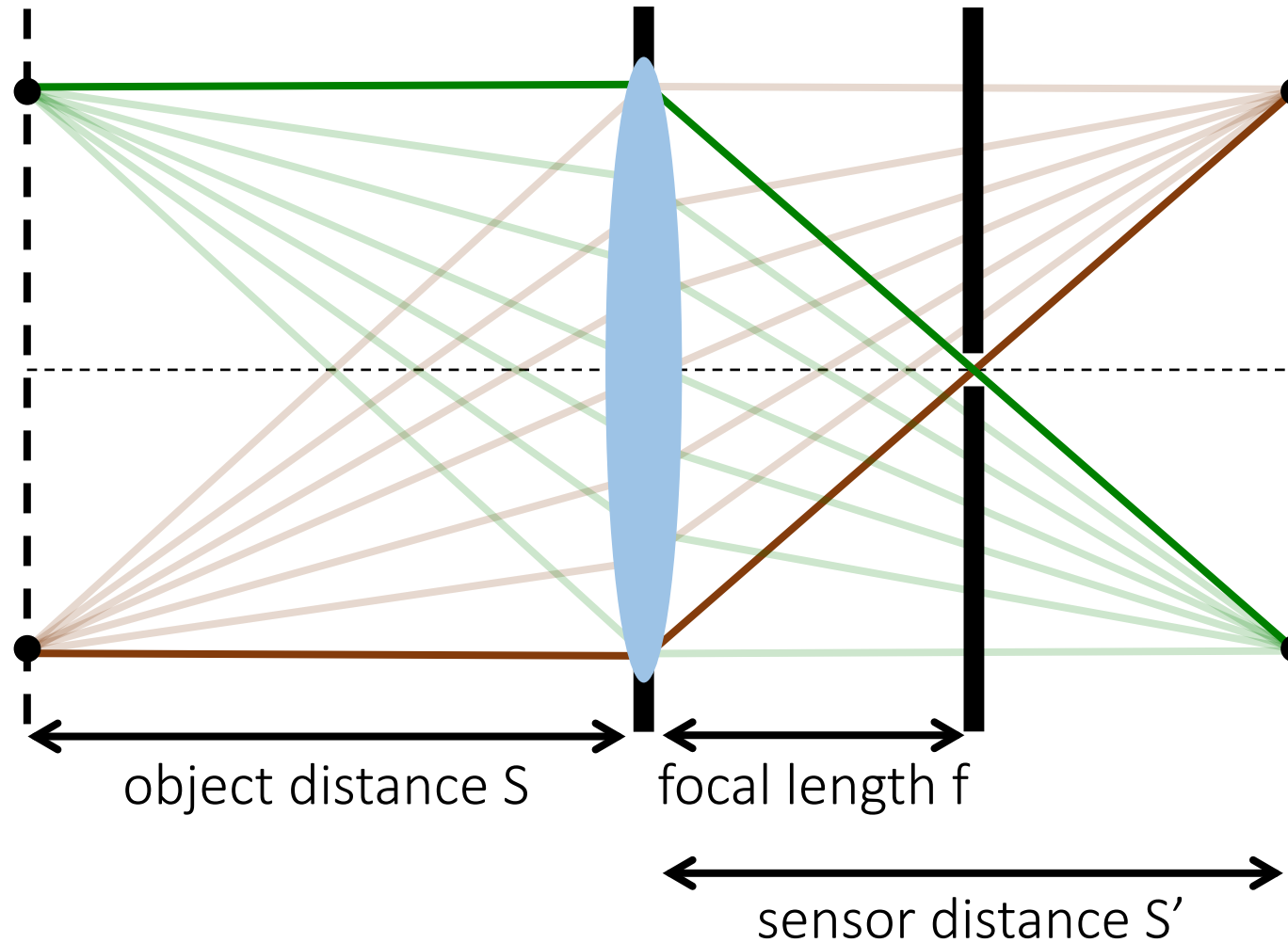

Telecentric lens

Place a pinhole at focal length, so that only rays parallel to primary ray pass through.

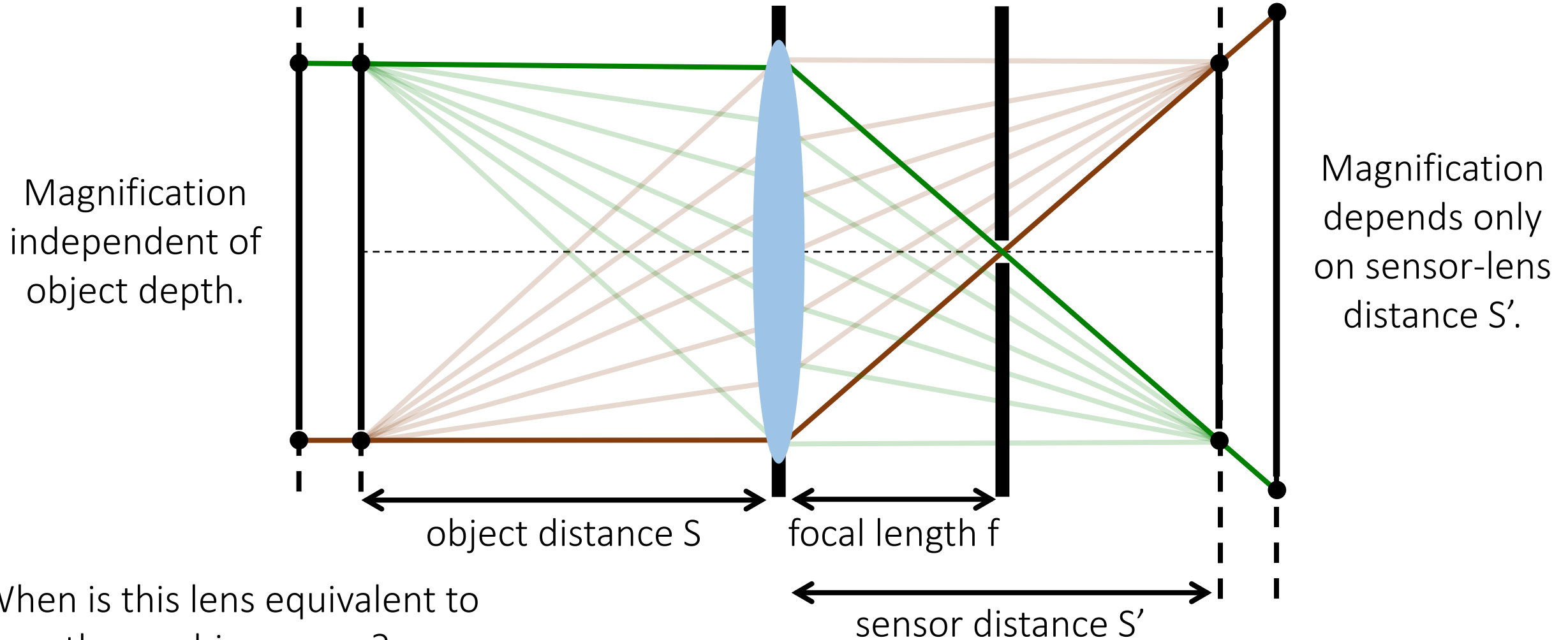

When is this lens equivalent to an orthographic camera?

Regular vs telecentric lens

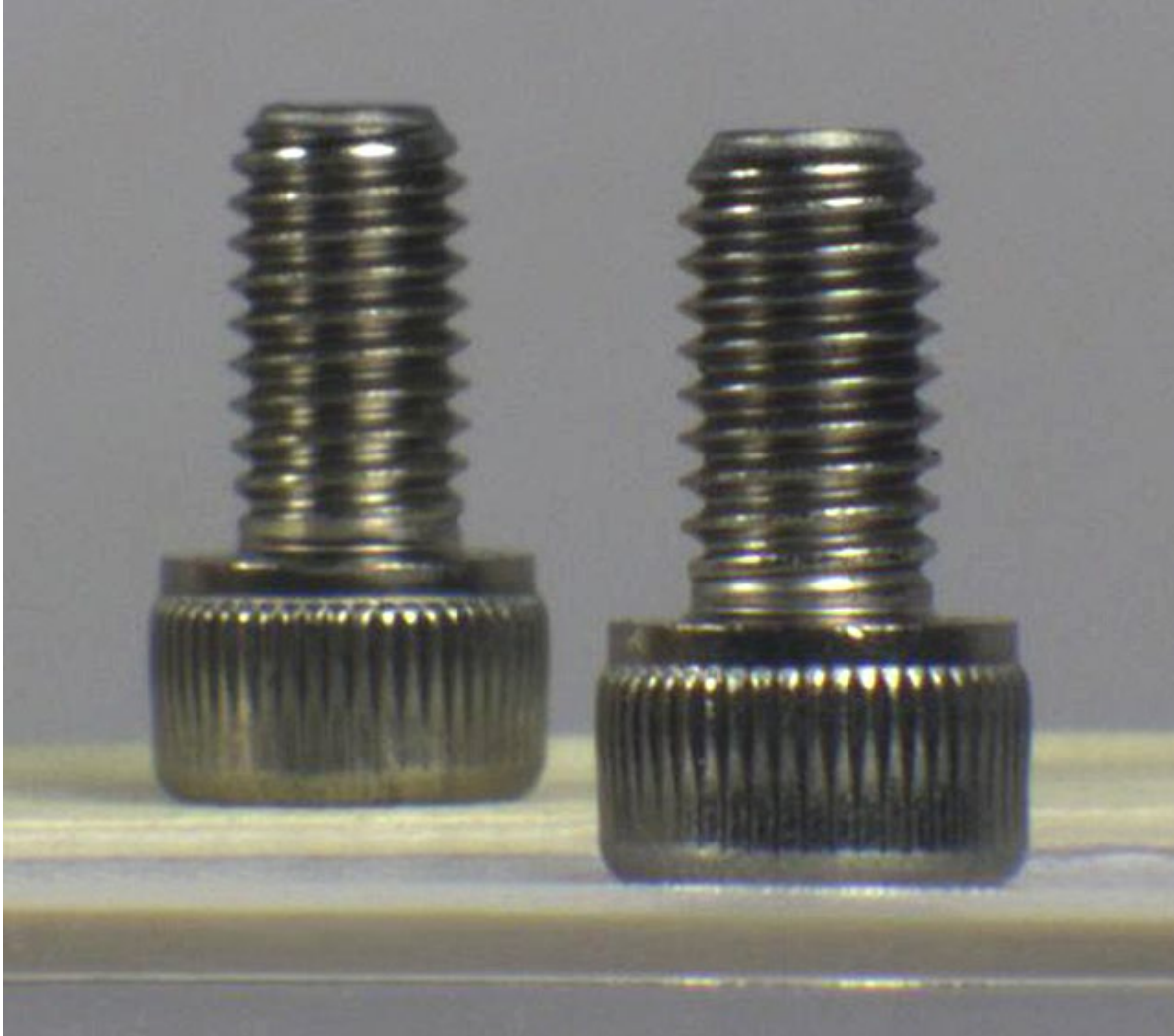

regular lens

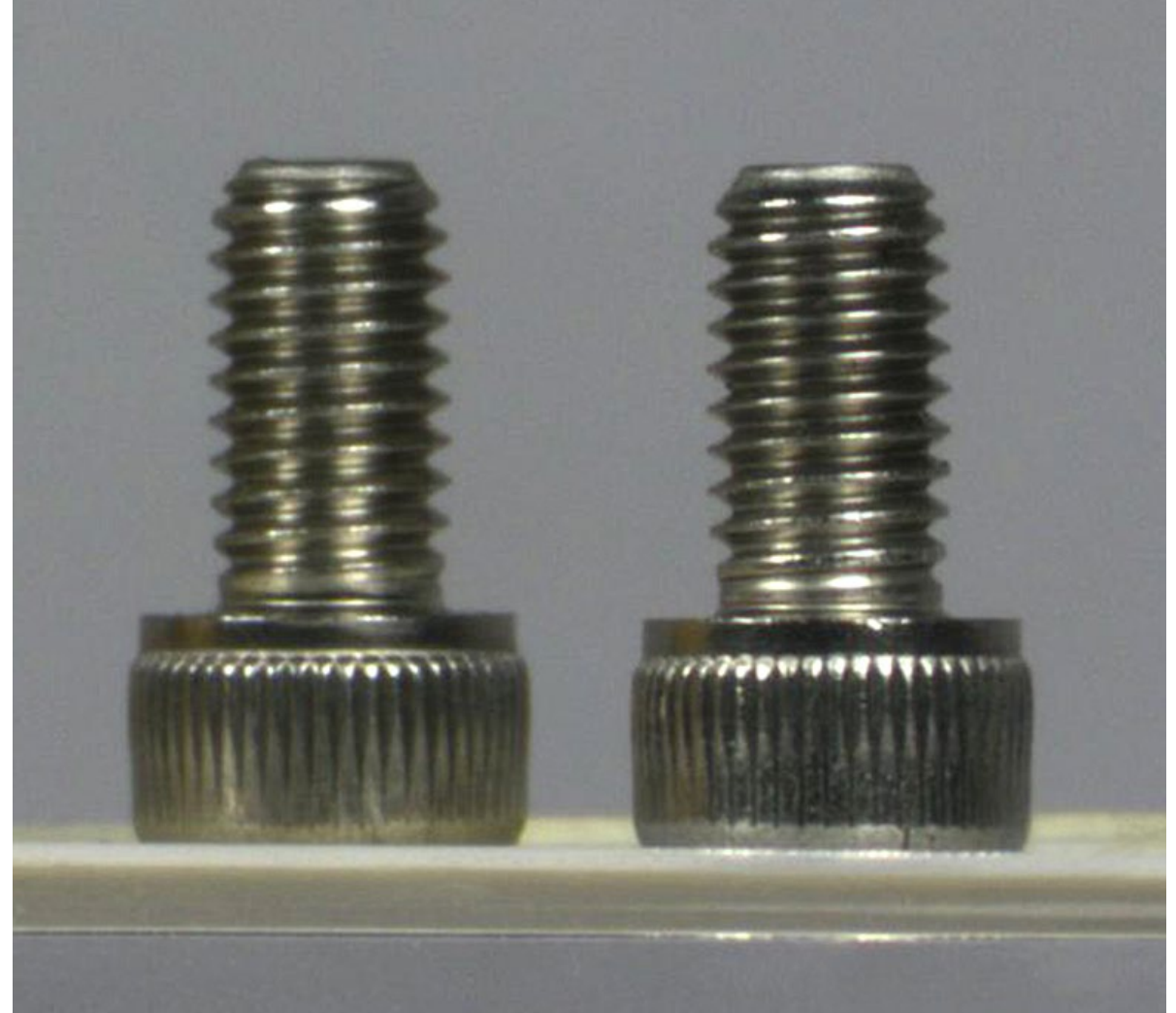

telecentric lens

References

Basic reading:

- Szeliski textbook, Section 2.1.5, 2.2.3.
- Pedrotti, Pedrotti, and Pedrotti, Introduction to Optics.
Chapters 2 and 3 have a detailed overview of basic geometric optics and lenses.

Additional reading:

- Hartley and Zisserman, “Multiple View Geometry in Computer Vision,” Cambridge University Press 2004.
Chapter 6 of this book is a very thorough treatment of camera models.
- Goodman, “Introduction to Fourier Optics,” W.H. Freeman 2004.
The standard reference on Fourier optics, chapter 4 covers aperture diffraction.
- Ray, “Applied Photographic Optics,” Focal Press 2002.
A great book covering everything about photographic optics.
- Torralba and Freeman, “Accidental Pinhole and Pinspeck Cameras,” CVPR 2012.
The eponymous paper discussed in the slides.
- Watanabe and Nayar, “Telecentric Optics for Focus Analysis,” PAMI 1997.
An early computational photography paper analyzing the ray optics and explaining the advantages and disadvantages of telecentric lenses relative to conventional lenses.